

# SEDAR

## Southeast Data, Assessment, and Review

---

### SEDAR 61

### Stock Assessment Report

# Gulf of Mexico Red Grouper

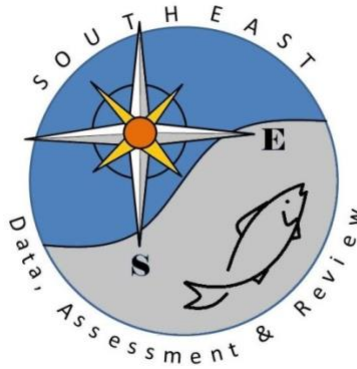
**July 2019**

SEDAR  
4055 Faber Place Drive, Suite 201  
North Charleston, SC 29405

## Table of Contents

Section I. Introduction	PDF page	3
Section II. Assessment Report	PDF page	34

# SEDAR



## Southeast Data, Assessment, and Review

---

### SEDAR 61

## Gulf of Mexico Red Grouper

### SECTION I: Introduction

SEDAR

4055 Faber Place Drive, Suite 201  
North Charleston, SC 29405

## Introduction

SEDAR 61 addressed the stock assessment for Gulf of Mexico red grouper. The assessment process consisted of in-person workshops, as well as a series of webinars. The in-person Workshop was held September 11-13, 2018 in St. Petersburg, FL. Assessment webinars were held between November 2018 and May 2019.

The Stock Assessment Report is organized into 2 sections. Section I – Introduction contains a brief description of the SEDAR Process, Assessment and Management Histories for the species of interest, and the management specifications requested by the Cooperator. Section II is the Assessment Process report. This section details the assessment model, as well as documents any data recommendations that arise for new data sets presented during this assessment process, or changes to data sets used previously.

The final Stock Assessment Reports (SAR) for Gulf of Mexico red grouper was disseminated to the public in July 2019. The Council’s Scientific and Statistical Committee (SSC) will review the SAR for its stock. The SSCs are tasked with recommending whether the assessments represent Best Available Science, whether the results presented in the SARs are useful for providing management advice and developing fishing level recommendations for the Council. An SSC may request additional analyses be conducted or may use the information provided in the SAR as the basis for their Fishing Level Recommendations (e.g., Overfishing Limit and Acceptable Biological Catch). The Gulf of Mexico Fishery Management Council’s SSC will review the assessment at its September 2019 meeting, followed by the Council receiving that information at its October 2019 meeting. Documentation on SSC recommendations is not part of the SEDAR process and is handled through each Council.

### 1 SEDAR PROCESS DESCRIPTION

SouthEast Data, Assessment, and Review (**SEDAR**) is a cooperative Fishery Management Council process initiated in 2002 to improve the quality and reliability of fishery stock assessments in the South Atlantic, Gulf of Mexico, and US Caribbean. SEDAR seeks improvements in the scientific quality of stock assessments and the relevance of information available to address fishery management issues. SEDAR emphasizes constituent and stakeholder participation in assessment development, transparency in the assessment process, and a rigorous and independent scientific review of completed stock assessments.

SEDAR is managed by the Caribbean, Gulf of Mexico, and South Atlantic Regional Fishery Management Councils in coordination with NOAA Fisheries and the Atlantic and Gulf States Marine Fisheries Commissions. Oversight is provided by a Steering Committee composed of NOAA Fisheries representatives: Southeast Fisheries Science Center Director and the Southeast Regional Administrator; Regional Council representatives: Executive Directors and Chairs of the



South Atlantic, Gulf of Mexico, and Caribbean Fishery Management Councils; a representative from the Highly Migratory Species Division of NOAA Fisheries, and Interstate Commission representatives: Executive Directors of the Atlantic States and Gulf States Marine Fisheries Commissions.

SEDAR is normally organized around two workshops and a series of webinars. First is the Data Workshop, during which fisheries, monitoring, and life history data are reviewed and compiled. The second stage is the Assessment Process, which is conducted via a workshop and/or a series of webinars, during which assessment models are developed and population parameters are estimated using the information provided from the Data Workshop. The final step is the Review Workshop, during which independent experts review the input data, assessment methods, and assessment products. The completed assessment, including the reports of all 3 stages and all supporting documentation, is then forwarded to the Council SSC for certification as ‘appropriate for management’ and development of specific management recommendations.

SEDAR workshops are public meetings organized by SEDAR staff and the lead Cooperator. Workshop participants are drawn from state and federal agencies, non-government organizations, Council members, Council advisors, and the fishing industry with a goal of including a broad range of disciplines and perspectives. All participants are expected to contribute to the process by preparing working papers, contributing, providing assessment analyses, and completing the workshop report.

**2 MANAGEMENT OVERVIEW**

**2.1. Reef Fish Fishery Management Plan and Amendments**

*Original FMP:*

The Reef Fish Fishery Management Plan was implemented in November 1984. The regulations, designed to rebuild declining reef fish stocks, included: (1) prohibitions on the use of fish traps, roller trawls, and powerhead-equipped spear guns within an inshore stressed area; (2) a minimum size limit of 13 inches total length (TL) for red snapper with the exceptions that for-hire boats were exempted until 1987 and each angler could keep 5 undersize fish; and, (3) data reporting requirements.

Description of Action	FMP/Amendment	Effective Date
Established a survival rate of biomass into the stock of spawning age fish to achieve at least 20% spawning stock biomass per recruit (SSBR). Set an 11.0 million-pound whole weight commercial quota for groupers, with the	Amendment 1	1990

<p>commercial quota divided into a 9.2 million pound whole weight shallow-water grouper quota and a 1.8 million-pound whole weight deepwater grouper quota. As a result of a change in the gutted to whole weight conversion ratio (from 1.18 to 1.05), these quotas were subsequently adjusted to 9.8 million pounds whole weight for all groupers, 8.2 million pounds whole weight shallow-water grouper, and 1.6 million pounds whole weight deep-water grouper. Shallow-water grouper were defined as black grouper, gag, red grouper, Nassau grouper, yellowfin grouper, yellowmouth grouper, rock hind, red hind, speckled hind, and scamp (until the shallow-water grouper quota is filled). Deep-water grouper were defined as misty grouper, snowy grouper, yellowedge grouper, warsaw grouper, and scamp once the shallow-water grouper quota is filled. Set a 20 inch total length minimum size limit and a five-grouper recreational daily bag limit. Limited trawl vessels to the recreational size and daily bag limits of reef fish.</p>		
<p>Speckled hind moved from shallow-water grouper to deep-water grouper aggregate. Rebuilding target changed from 20% SSBR to 20% spawning potential ratio (SPR). The time frame to rebuild overfished stocks is specified as 1 ½ generation times.</p>	<p>Amendment 3</p>	<p>1991</p>
<p>Commercial reef fish permit moratorium established for three years</p>	<p>Amendment 4</p>	<p>1992</p>
<p>Fish trap endorsement and three year moratorium established</p>	<p>Amendment 5</p>	<p>1994</p>
<p>Extended commercial reef fish permit moratorium until January 1996.</p>	<p>Amendment 9</p>	<p>1994</p>
<p>Commercial reef fish permit moratorium extended until December 30, 2000. Reef fish</p>	<p>Amendment 11</p>	<p>1996</p>

permit requirement established for headboats and charter vessels.		
10-year phase-out of fish traps in EEZ established (February 7, 1997 – February 7, 2007).	Amendment 14	1997
Commercial reef fish permit moratorium extended until December 31, 2005.	Amendment 17	2000
(1) Prohibits vessels from retaining reef fish caught under recreational bag/possession limits when commercial quantities of Gulf reef fish are aboard, (2) adjusts the maximum crew size on charter vessels that also have a commercial reef fish permit and a USCG certificate of inspection (COI) to allow the minimum crew size specified by the COI when the vessel is fishing commercially for more than 12 hours, (3) prohibits the use of reef fish for bait except for sand perch or dwarf sand perch, and (4) requires electronic VMS aboard vessels with federal reef fish permits, including vessels with both commercial and charter vessel permits (implemented May 6, 2007).	Amendment 18A	2006
Also known as Generic Essential Fish Habitat (EFH) Amendment 2. Established two marine reserves off the Dry Tortugas where fishing for any species and anchoring by fishing vessels is prohibited.	Amendment 19	2002
3-year moratorium on reef fish charter/headboat permits established	Amendment 20	2002, but implementation deferred until June 16, 2003
Continued the Steamboat Lumps and Madison-Swanson reserves for an additional six years, until June 2010. In combination with the initial four-year period (June 2000-June 2004), this allowed a total of ten years in which to evaluate the effects of these reserves.	Amendment 21	2003

<p>Permanent moratorium established for commercial reef fish permits.</p>	<p>Amendment 24</p>	<p>2005</p>
<p>Permanent moratorium established for charter and headboat reef fish permits, with periodic reviews at least every 10 years.</p>	<p>Amendment 25</p>	<p>2006</p>
<p>Addressed the use of non-stainless steel circle hooks when using natural baits to fish for Gulf reef fish effective June 1, 2008, and required the use of venting tools and dehooking devices when participating in the commercial or recreational reef fish fisheries effective June 1, 2008.</p>	<p>Amendment 27</p>	<p>2008</p>
<p>Established an individual fishing quota (IFQ) system for the commercial grouper and tilefish fisheries.</p>	<p>Amendment 29</p>	<p>2010</p>
<p>Sets interim allocations of gag and red grouper catches between recreational and commercial fisheries, and makes adjustments to the red grouper total allowable catch (TAC) to reflect the current status of the stock, which is currently at OY levels. Additionally, the amendment establishes annual catch limits (ACLs) and accountability measures (AMs) for the commercial and recreational red grouper fisheries and commercial aggregate shallow-water fishery.</p> <p>For the commercial sector, the amendment for 2009 reduces the aggregate shallow-water grouper quota from 8.80 mp to 7.8 mp, and increases the red grouper quota from 5.31 mp to 5.75 mp. Repeals the commercial closed season of February 15 to March 15 on gag, black and red grouper, and replaces it with a January through April seasonal area closure to all fishing at the Edges 40 fathom contour, a 390 nautical square mile gag spawning region northwest of</p>	<p>Amendment 30B</p>	<p>2009</p>

<p>Steamboat Lumps. Increases the red grouper recreational bag limit from one fish to two.</p>		
<p>Established additional restrictions on the use of bottom longline gear in the eastern Gulf of Mexico in order to reduce bycatch of endangered sea turtles, particularly loggerhead sea turtles. (1) Prohibits the use of bottom longline gear shoreward of a line approximating the 35-fathom contour from June through August; (2) reduces the number of longline vessels operating in the fishery through an endorsement provided only to vessel permits with a demonstrated history of landings, on average, of at least 40,000 pounds of reef fish annually with fish traps or longline gear during 1999-2007; and (3) restricts the total number of hooks that may be possessed onboard each reef fish bottom longline vessel to 1,000, only 750 of which may be rigged for fishing. The boundary line was initially moved from 20 to 50 fathoms by emergency rule effective May 18, 2009. That rule was replaced on October 16, 2009 by a rule under the Endangered Species Act moving the boundary to 35 fathoms and implementing the maximum hook provisions.</p>	<p>Amendment 31</p>	<p>2010</p>
<p>Set the commercial and recreational gag annual catch limits for 2012 through 2015 and beyond. Set the constant catch commercial red grouper annual catch limit at 6.03 mp and the recreational red grouper annual catch limit at 1.90 mp. Set the commercial and recreational gag annual catch targets for 2012 through 2015 and beyond. Implemented commercial gag quotas for 2012 through 2015 and beyond that included a 14% reduction from the annual catch target to account for additional dead discards of gag resulting from the reduced harvest. Modified grouper IFQ multi-use allocations. Simplified the commercial shallow-water grouper accountability measures by using the individual fishing quota program to</p>	<p>Amendment 32</p>	<p>2012</p>

<p>reduce redundancy. Added an overage adjustment and in-season measures to the recreational gag and red grouper accountability measures to avoid exceeding the annual catch limit. Added an accountability measure for the red grouper bag limit that would reduce the four red grouper bag limit in the future to three red grouper, and then to two red grouper, if the red grouper recreational annual catch limit is exceeded.</p>		
<p>Revised the post-season recreational accountability measure that reduces the length of the recreational season for all shallow-water grouper in the year following a year in which the ACL for gag or red grouper is exceeded. The modified accountability measure reduces the recreational season of only the species for which the ACL was exceeded. Modified the reef fish framework procedure to include accountability measures to the list of items that can be changed through the standard framework procedure.</p>	<p>Amendment 38</p>	<p>2013</p>

## 2.2. Generic Amendments

**Generic Sustainable Fisheries Act Amendment:** partially approved and implemented in **November 1999**, set the Maximum Fishing Mortality Threshold (MFMT) for most reef fish stocks at  $F_{30\%}$  SPR. Estimates of maximum sustainable yield, Minimum Stock Size Threshold (MSST), and optimum yield were disapproved because they were based on SPR proxies rather than biomass based estimates.

**Generic ACL/AM Amendment:** Established in-season and post-season accountability measures for all stocks that did not already have such measures defined. This includes the “other shallow-water grouper species” complex. The accountability measure states that if an ACL is exceeded, in subsequent years an in-season accountability measure will be implemented that would close shallow-water grouper fishing (for all shallow-water grouper species combined) when the ACL is reached or projected to be reached.

## 2.3. Regulatory Amendments

**July 1991:** Implemented November 12, 1991, provided a one-time increase in the 1991 quota for shallow-water grouper from 9.2 mp ww to 9.9 mp ww to provide the commercial fishery an opportunity to harvest 0.7 MP that was not harvested in 1990 [56 FR 58188].

In 1991, the conversion factor used to convert grouper gutted weight to whole weight was changed from 1.18 to 1.05. Consequently the base quotas for grouper were changed to 9.8 mp ww (all grouper), 8.2 mp ww (shallow-water grouper), and 1.6 mp ww (deep-water grouper). Since commercially harvested grouper are typically landed in gutted condition, this did not change the actual landings, only the whole weight equivalents.

**November 1991:** Implemented June 22, 1992, raised the 1992 commercial quota for shallow-water grouper to 9.8 mp ww after a red grouper stock assessment indicated that the red grouper SPR was substantially above the Council's minimum target of 20% [57 FR 21751].

**August 1999:** Implemented June 19, 2000, increased the commercial size limit for gag and black grouper from 20 to 24 inches TL, increased the recreational size limit for gag from 20 to 22 inches TL, implemented a seasonal closure on commercial harvest and prohibited commercial sale of gag, black, and red grouper each year from February 15 to March 15 (during the peak of gag spawning season), and established two marine reserves (Steamboat Lumps and Madison-Swanson) with a 4-year sunset clause that are closed year-round to fishing for all species under the Council's jurisdiction [65 FR 31827].

**October 2005:** Implemented January 1, 2006, established a 6,000 lb gw aggregate deepwater grouper and shallow-water grouper trip limit for the commercial grouper fishery, replacing the 10,000/7,500/5,500 step-down trip limit that had been implemented by emergency rule for 2005 [70 FR 77057].

**March 2006:** Implemented July 15, 2006, established a recreational red grouper bag limit of one fish per person per day as part of the five grouper per person aggregate bag limit, and prohibited for-hire vessel captains and crews from retaining bag limits of any grouper while under charter [71 FR 34534]. An additional provision established a recreational closed season for red grouper, gag and black grouper from February 15 to March 15 each year (matching a previously established commercial closed season) beginning with the 2007 season.

**September 2010:** Implemented January 1, 2011, reduced the total allowable catch for red grouper from 7.57 million pounds gutted weight to 5.68 million pounds gutted weight, based on the optimum yield projection from a March 2010 re-run of the projections from the 2009 red grouper update assessment. Although the stock was found to be neither overfished nor undergoing overfishing, the update assessment found that spawning stock biomass levels had decreased since 2005, apparently due to an episodic mortality even in 2005 which appeared to be related to an extensive red tide that year. Based on the 76%:34% commercial and recreational allocation of red grouper, the commercial quota was reduced from 5.75 to 4.32 million pounds gutted weight, and the recreational allocation was reduced from 1.82 to 1.36 million pounds gutted weight. No changes were made to the recreational fishing regulations as the recreational landings were already below the adjusted allocation in recent years.

**August 2011:** Increased the 2011 total allowable catch to 6.88 million pounds gutted weight and allowed the total allowable catch to increase from 2012 to 2015. The increases in TAC are contingent upon the TAC not being exceeded in previous years. If TAC is exceeded in a given year, it will remain at that year's level until the effects of the overage are evaluated by the Scientific and Statistical Committee. The amendment also increases the red grouper bag limit to 4 fish per person.

**Framework Action - December 2012:** Established the 2013 gag recreational fishing season to open on July 1 and remain open until the recreational annual catch target is projected to be taken. Also eliminated the February 1 through March 31 recreational shallow-water grouper closed season shoreward of 20 fathoms (except for gag). However, the closed season remains in effect beyond 20 fathoms to protect spawning aggregations of gag and other species that spawn offshore during that time.

**Framework Action - December 2012:** Established the 2013 gag recreational fishing season to open on July 1 and remain open until the recreational annual catch target is projected to be taken. Also eliminated the February 1 through March 31 recreational shallow-water grouper closed season shoreward of 20 fathoms (except for gag). However, the closed season remains in effect beyond 20 fathoms to protect spawning aggregations of gag and other species that spawn offshore during that time.

## 2.4. Secretarial Amendments

**Secretarial Amendment 1:** Implemented July 15, 2004. Beginning with this amendment, all grouper TACs, quotas, and other catch levels are expressed in units of gutted weight rather than whole weight to avoid complications from the Accumulated Landings System using a different gutted-to-whole weight conversion factor than the Southeast Fisheries Science Center. Established a rebuilding plan, a 5.31 mp gutted weight (gw) commercial quota, and a 1.25 mp gw recreational target catch level for red grouper. Also reduced the commercial quota for shallow-water grouper from 9.35 to 8.8 mp gw and reduced the commercial quota for deepwater grouper from 1.35 to 1.02 mp gw. The recreational bag limit for red grouper was reduced to two fish per person per day.

## 2.5. Emergency and Interim Rules

**Emergency Rule - Published February 15, 2005:** established a series of trip limits for the commercial grouper fishery in order to extend the commercial fishing season. The trip limit was initially set at 10,000 lbs gw. If on or before August 1 the fishery is estimated to have landed more than 50% of either the shallow-water grouper or the red grouper quota, then a 7,500 lb gw trip limit takes effect (*took effect July 9, 2005*); and if on or before October 1 the fishery is estimated to have landed more than 75% of either the shallow-water grouper or the red grouper quota, then a 5,500 lb gw trip limit takes effect (*took effect August 4, 2005*) [70 FR 8037].



**Interim Rule - Published July 25, 2005:** proposed for the period August 9, 2005 through January 23, 2006, a temporary reduction in the recreational red grouper bag limit from two to one fish per person per day, in the aggregate grouper bag limit from five to three grouper per day, and a closure of the recreational fishery, from November - December 2005, for all grouper species [70 FR 42510]. These measures were proposed in response to an overharvest of the recreational allocation of red grouper under the Secretarial Amendment 1 red grouper rebuilding plan. The closed season was applied to all grouper in order to prevent effort shifting from red grouper to other grouper species and an increased bycatch mortality of incidentally caught red grouper. However, the rule was challenged by organizations representing recreational fishing interests. On October 31, 2005, a U.S. District Court judge ruled that an interim rule to end overfishing can only be applied to the species that is undergoing overfishing. Consequently, the reduction in the aggregate grouper bag limit and the application of the closed season to all grouper were overturned. The reduction in the red grouper bag limit to one per person and the November-December 2005 recreational closed season on red grouper only were allowed to proceed. The approved measures were subsequently extended through July 22, 2006 by a temporary rule extension published January 19, 2006 [71 FR 3018].

**Emergency Rule - Implemented May 18, 2009 through October 28, 2009:** Prohibited the use of bottom longline gear to harvest reef fish east of 85°30' W longitude in the portion of the exclusive economic zone (EEZ) shoreward of the coordinates established to approximate a line following the 50-fathom (91.4-m) contour as long as the 2009 deepwater grouper and tilefish quotas are unfilled. After the quotas have been filled, the use of bottom longline gear to harvest reef fish in water of all depths east of 85°30' W longitude are prohibited [74 FR 20229].

**Emergency Rule - Implemented May 3, 2010 through November 15, 2010:** NMFS issued an emergency rule to temporarily close a portion of the Gulf of Mexico EEZ to all fishing [75 FR 24822] in response to an uncontrolled oil spill resulting from the explosion on April 20, 2010 and subsequent sinking of the Deepwater Horizon oil rig approximately 36 nautical miles (41 statute miles) off the Louisiana coast. The initial closed area extended from approximately the mouth of the Mississippi River to south of Pensacola, Florida and covered an area of 6,817 square statute miles. The coordinates of the closed area were subsequently modified periodically in response to changes in the size and location of the area affected by the spill. At its largest size on June 1, 2010, the closed area covered 88,522 square statute miles, or approximately 37 percent of the Gulf of Mexico EEZ. This closure was implemented for public safety.

**Interim Rule - Published on December 1, 2010:** [75 FR 74654] Reduced gag landings consistent with ending overfishing. This interim rule implemented conservative management measures while a rerun of the update stock assessment was being completed. At issue was the treatment of dead discarded fish in the assessment. The rule reduced the commercial quota to 100,000 pounds gutted weight, suspended the use of red grouper multi-use individual fishing quota allocation so it would not be used to harvest gag, and to temporarily halted the recreational harvest of gag until recreational fishing management measures being developed in Amendment 32 could be implemented to allow harvest at the appropriate levels.

**Interim Rule – Effective from June 1, 2011 through November 27, 2011:** Set the commercial gag quota at 430,000 pounds gutted weight (including the 100,000 pounds previously allowed) for the 2011 fishing year, and temporarily suspended the use of red grouper multi-use IFQ allocation so it cannot be used to harvest gag. It also set a two-month recreational gag fishing season from September 16 through November 15. This temporary rule can be extended for another 186 days [76 FR 31874].

**Interim Rule – Effective from May 5, 2014 through December 31, 2014:** Reduced the recreational bag limit for red grouper to three fish per person per day within the four fish per person daily aggregate grouper recreational bag limit [79 FR 24353]. This rule expired and the recreational bag limit for red grouper increased to four fish per person per day on January 1, 2015.

## 2.6. Management Parameters and Projection Specifications

**Table 2.6.1. General Management Information**

Species	Red Grouper
Management Unit	Gulf of Mexico
Management Unit Definition	Gulf of Mexico
Management Entity	Gulf of Mexico Fishery Management Council
Management Contacts SERO / Council	Ryan Rindone (GMFMC) Rick Malinowski (SERO)
Stock exploitation status (from SEDAR 42)	No overfishing
Stock biomass status (from SEDAR 42)	Not overfished

**Table 2.6.2. Specific Management Criteria**

(Provide details on the management criteria to be estimated in this assessment) Note: mp = million pounds; gw = gutted weight.

Criteria	Current- from SEDAR 42		Proposed	
	Definition	Value	Definition	Value
MSST	$(1-M)*SSB_{MSY}$ $M=0.144$	2,095,402 eggs/recruit	Value from the most recent stock assessment based on $MSST = 0.5 *BMSY$	SEDAR 61
MFMT	$F_{MSY}$ $F_{30\%SPR}$	0.212	$F_{MSY}$ or proxy from the most recent stock assessment	SEDAR 61

MSY	F <sub>MSY</sub> F <sub>30%SPR</sub>	0.212	Yield at F <sub>MSY</sub> , landings and discards, pounds and numbers	SEDAR 61
F <sub>MSY</sub>	F <sub>MSY</sub>	F <sub>30%SPR</sub>		SEDAR 61
SSB <sub>MSY</sub>	SSB @ F <sub>30%SPR</sub>	2,447,900 eggs/recruit	Spawning stock biomass (median from probabilistic analysis)	SEDAR 61
F Targets (i.e., F <sub>OY</sub> )	75% of F <sub>MSY</sub>	0.164	75% F <sub>MSY</sub>	SEDAR 61
Yield at F <sub>Target</sub> (Equilibrium)	landings and discards, pounds and numbers	0.943	landings and discards, pounds and numbers	SEDAR 61
M	Natural Mortality, mean across ages	0.144	Natural Mortality, mean across ages	SEDAR 61
Terminal F	Exploitation (2013)	0.126	Exploitation (2017)	SEDAR 61
Terminal Biomass <sup>1</sup>	Biomass (2013)	2,905,630 eggs/recruit	Biomass (2017)	SEDAR 61
Exploitation Status	F/MFMT (2013)	0.594	F/MFMT (2017)	SEDAR 61
Biomass Status <sup>1</sup>	B/MSST (2013) B/B <sub>MSY</sub> (2013)	1.387 1.187	B/MSST (2017) B/B <sub>MSY</sub> (2017)	SEDAR 61
Generation Time				SEDAR 61
T <sub>Rebuild</sub> (if appropriate)	2032	-		SEDAR 61

*NOTE: "Proposed" columns are for indicating any definitions that may exist in FMPs or amendments that are currently under development and should therefore be evaluated in the current assessment. "Current" is those definitions in place now. Please clarify whether landings parameters are 'landings' or 'catch' (Landings + Discard). If 'landings', please indicate how discards are addressed.*

**Table 2.6.3. General projection information.**

*(This provides the basic information necessary to bridge the gap between the terminal year of the assessment and the year in which any changes may take place or specific alternative exploitation rates should be evaluated, and guidance for the information managers required from the projection analyses.)*

Requested Information	Value
First Year of Management	2019 Fishing Year
Interim basis	- ACL, if ACL is met - Average exploitation, if ACL is not met
Projection Outputs	By stock and fishing year
Landings	pounds and numbers
Discards	pounds and numbers
Exploitation	F & Probability F>MFMT

Biomass (total or SSB, as appropriate)	SSB & Probability SSB>MSST (and Prob. SSB>B <sub>MSY</sub> if under rebuilding plan)
Recruits	Number

**Table 2.6.4.** Base Run Projections Specifications. Long Term and Equilibrium conditions.

Criteria	Definition	If overfished	if overfishing	Not overfished, no overfishing
Projection Span	Years	T <sub>Rebuild</sub>	10	10
Projection Values	F <sub>Current</sub>	X	X	X
	F <sub>MSY</sub> (proxy)	X	X	X
	75% F <sub>MSY</sub>	X	X	X
	F <sub>Rebuild</sub>	X		
	F=0	X		

NOTE: Exploitation rates for projections may be based on point estimates from the base run or the median of such values from evaluation of uncertainty. The objective is for projections to be based on the same criteria as the management specifications.

**Table 2.6.5.** P-Star Projections. Short term specifications for OFL and ABC recommendations. Additional P-star projections may be requested by the SSC once the ABC control rule is applied.

Criteria		Overfished	Not overfished
Projection Span	Years	10	10
Probability Values	50%	Probability of stock rebuild	Probability of overfishing
	27.5% <sup>1</sup>		

The following should be provided regardless of whether the stock is healthy or overfished:

- OFL: yield at F<sub>MSY</sub> (or F<sub>30% SPR</sub> proxy)
- OY: yield at 75% for F<sub>30% SPR</sub>
- Equilibrium MSY and equilibrium OY

If the stock is overfished, the following should also be provided:

- F<sub>REBUILD</sub> and the yield at F<sub>REBUILD</sub> (where the rebuilding time frame is 10 years)
- A probability distribution function (PDF) that can be used along with the P\* selected by the SSC to determine ABC. If multiple model runs are provided, this may need to wait until the SSC selects which model run to use for management.

The SSC typically recommends OFL and ABC yield streams for 3-5 years out. Yield streams provided by assessment scientists should go beyond five years. If a 10-year rebuilding plan is needed, yield streams should be provided for 10 years.

**Table 2.6.6. Quota Calculation Details**

Note: mp = million pounds; gw = gutted weight.

Current ACL Value (2018)	10.77 mp gw
Next Scheduled Quota Change	2019
Annual or averaged quota?	Annual
Does the quota include bycatch/discard?	A+B1

Quotas are conditioned upon exploitation. Bycatch/discard estimates are considered in setting the quota; however, quota values are for landed fish only.

## 2.7. Management and Regulatory Timeline

### 2.7.1 Pertinent Federal Management Regulations

#### Harvest Restrictions – Trip Limits

\*Trip limits do not apply during closures (if season is closed, then trip limit i

First Yr In Effect	Last Yr In Effect	Effective Date	End Date	Fishery	Bag Limit Per Person/Day	Trip Limit Per Boat/Day	Region Affected	FR Reference	FR Section	Amendment Number or Rule Type
2005	2005	3/3/2005	6/8/2005	Com	NA	10,000 lbs gw; DWG <sup>1</sup> & SWG <sup>2</sup>	Gulf of Mexico EEZ	70 FR 8037	622.44	Emergency Rule
2005	2005	6/9/2005	8/3/2005	Com	NA	7,500 lbs gw; DWG <sup>1</sup> & SWG <sup>2</sup>	Gulf of Mexico EEZ	70 FR 33033	622.44	Temporary Rule
2005	2005	8/4/2005	12/31/2005	Com	NA	5,500 lbs gw; SWG <sup>2</sup>	Gulf of Mexico EEZ	70 FR 42279	622.44	Temporary Rule
2006	2009	1/1/2006	12/31/2009	Com	NA	6,000 lbs gw; DWG <sup>1</sup> & SWG <sup>2</sup>	Gulf of Mexico EEZ	70 FR 77057	622.44	Reef Fish Regulatory Amendment
2010	Ongoing	1/1/2010	Ongoing	Com	NA	IFQ	Gulf of Mexico EEZ	74 FR 44732	622.2	Reef Fish Amendment 29
1990	2004	4/23/1990	7/14/2004	Rec	5 grouper aggregate	NA	Gulf of Mexico EEZ	55 FR 2078	641.24	Reef Fish Amendment 1
2004	2005	7/15/2004	8/8/2005	Rec	2 per person within 5 grouper aggregate	NA	Gulf of Mexico EEZ	69 FR 33315	622.39	Secretarial Amendment 1
2005	2006	8/9/2005	1/23/2006	Rec	1 per person within 3 grouper aggregate	NA	Gulf of Mexico EEZ	70 FR 42510	622.39	Temporary Rule
2006	2009	1/24/2006	5/17/2009	Rec	1 per person within 5 grouper aggregate	NA	Gulf of Mexico EEZ	71 FR 3018 71 FR 34534	622.39	Temporary Rule Reef Fish Regulatory Amendment
2009	2011	5/18/2009	11/1/2011	Rec	2 per person within 4 grouper aggregate	NA	Gulf of Mexico EEZ	74 FR 17603	622.39	Reef Fish Amendment 30B
2011	2014	11/2/2011	5/4/2014	Rec	4 per person within 4 grouper aggregate	NA	Gulf of Mexico EEZ	76 FR 67618	622.39	Reef Fish Regulatory Amendment
2014	2014	5/5/2014	12/31/2014	Rec	3 per person within 4 grouper aggregate	NA	Gulf of Mexico EEZ	79 FR 24353	622.41	Temporary Rule
2015	2015	1/1/2015	5/6/2015	Rec	4 per person within 4 grouper aggregate	NA	Gulf of Mexico EEZ	79 FR 24353	622.38	Temporary Rule Expired
2015	Ongoing	5/7/2015	Ongoing	Rec	2 per person within 4 grouper aggregate	NA	Gulf of Mexico EEZ	80 FR 18552	622.38	Reef Fish Framework Action

<sup>1</sup>DWG: deep-water grouper (misty grouper, snowy grouper, yellowedge grouper, warsaw grouper, and speckled hind)

<sup>2</sup>SWG: shallow-water grouper (black, gag, red, red hind, rock hind, scamp, yellowfin, and yellowmouth)

Harvest Restrictions - Size Limits\*

\*Size limits do not apply during closures

<b>First Yr In Effect</b>	<b>Last Yr In Effect</b>	<b>Effective Date</b>	<b>End Date</b>	<b>Fishery</b>	<b>Size Limit</b>	<b>Length Type</b>	<b>Region Affected</b>	<b>FR Reference</b>	<b>FR Section</b>	<b>Amendment Number or Rule Type</b>
1990	2009	2/21/1990	5/17/2009	Com	20"	Minimum TL	Gulf of Mexico EEZ	55 FR 2078	641.21	Reef Fish Amendment 1
1990	Ongoing	2/21/1990	Ongoing	Rec	20"	Minimum TL	Gulf of Mexico EEZ	55 FR 2078	641.21	Reef Fish Amendment 1
2009	Ongoing	5/18/2009	Ongoing	Com	18"	Minimum TL	Gulf of Mexico EEZ	74 FR 17603	622.37	Reef Fish Amendment 30B

Harvest Restrictions – Fishery Closures\*

\*Area specific regulations are documented under spatial restrictions

First Yr In Effect	Last Year in Effect	Effective Date	End Date	Fishery	Closure Type	First Day Closed	Last Day Closed	Region Affected	FR Reference	FR Section	Amendment Number or Rule Type	Species Associated with Closure
2001	2009	6/19/2000	12/31/2009	Com	Seasonal	15-Feb	14-Mar <sup>1</sup>	Gulf of Mexico EEZ	65 FR 31827 74 FR 44732	622.34 622.2	Reef Fish Regulatory Amendment Reef Fish Amendment 29	Black, Red and Gag
2004	2004	11/15/2004	12/31/2004	Com	Quota	15-Nov	31-Dec	Gulf of Mexico EEZ	69 FR 65092	622.43	Notice of Closure	SWG: Black, Red, Gag, Scamp, Yellowfin, Rock Hind, Red Hind, and Yellowmouth
2005	2005	10/10/2005	12/31/2005	Com	Quota	10-Oct	31-Dec	Gulf of Mexico EEZ	70 FR 57802	622.43	Temporary Rule	SWG: Black, Red, Gag, Scamp, Yellowfin, Rock Hind, Red Hind, and Yellowmouth
2005	2005	8/9/2005	1/23/2006	Rec	Seasonal	1-Nov	31-Dec	Gulf of Mexico EEZ	70 FR 42510	622.34	Temporary Rule	Groupers
2007	2009	12/18/2006	5/17/2009	Rec	Seasonal	15-Feb	14-Mar <sup>1</sup>	Gulf of Mexico EEZ	71 FR 66878	622.34	Reef Fish Regulatory Amendment	Black, Red and Gag
2010	2013	5/18/2009	7/4/2013	Rec	Seasonal	1-Feb	31-Mar	Gulf of Mexico EEZ	74 FR 17603	622.34	Reef Fish Amendment 30B	SWG: Black, Red, Gag, Scamp, Yellowfin, Rock Hind, Red Hind, and Yellowmouth
2014	Ongoing	7/5/2013	Ongoing	Rec	Seasonal	1-Feb	31-Mar	Gulf of Mexico EEZ seaward of 20 fathoms	78 FR 33259	622.34	Reef Fish Framework Action	SWG: Black, Red, Gag, Yellowfin and Yellowmouth
2014	2014	9/16/2014	12/31/2014	Rec	Quota	4-Oct	31-Dec	Gulf of Mexico EEZ	79 FR 54668	622.41	Temporary Rule	Red Grouper
2015	2015	10/8/2015	12/31/2015	Rec	Quota	8-Oct	31-Dec	Gulf of Mexico EEZ	80 FR 59665	622.41	Temporary Rule	Red Grouper

<sup>1</sup>According to Fishery Bulletins, the 15-Feb to 15-Mar closures ended at 12:01 am 14-Mar, as such the last day closed is effectively 14-Mar (FB02-001, FB03-005, FB04-005, FB05-001, FB06-002, FB07-06, FB08-004, FB09-005)



Harvest Restrictions – Spatial Restrictions

Area	First Yr In Effect	Last Yr In Effect	Effective Date	End Date	Fishery	First Day Closed	Last Day Closed	Restriction in Area	FR Reference	FR Section	Amendment Number or Rule Type
Gulf of Mexico Stressed Areas	1984	Ongoing	11/8/1984	Ongoing	Both	Year round		Prohibited powerheads for Reef FMP	49 FR 39548	641.7	Original Reef Fish FMP
	1984	Ongoing	11/8/1984	Ongoing	Both	Year round		Prohibited pots and traps for Reef FMP	49 FR 39548	641.7	Original Reef Fish FMP
Alabama Special Management Zones	1994	Ongoing	2/7/1994	Ongoing	Both	Year round		Allow only hook-and line gear with three or less hooks per line and spearfishing gear for fish in Reef FMP	59 FR 966	641.23	Reef Fish Amendment 5
EEZ, inside 50 fathoms west of Cape San Blas, FL	1990	Ongoing	2/21/1990	Ongoing	Both	Year round		Prohibited longline and buoy gear for Reef FMP	55 FR 2078	641.7	Reef Fish Amendment 1
EEZ, inside 20 fathoms east of Cape San Blas, FL	1990	Ongoing	2/21/1990	Ongoing	Both	Year round		Prohibited longline and buoy gear for Reef FMP	55 FR 2078	NA	Reef Fish Amendment 1
EEZ, inside 50 fathoms east of Cape San Blas, FL	2009	2009	5/18/2009	10/15/2009	Both	18-May	28-Oct	Prohibited bottom longline for Reef FMP	74 FR 20229	622.34	Emergency Rule
EEZ, inside 35 fathoms east of Cape San Blas, FL	2009	2010	10/16/2009	5/25/2010	Both	Year round		Prohibited bottom longline for Reef FMP	74 FR 53889	223.206	Sea Turtle ESA Rule
	2010	Ongoing	5/26/2010	Ongoing	Rec	Year round		Prohibited bottom longline for Reef FMP	75 FR 21512	622.34	Reef Fish Amendment 31
	2010	Ongoing	5/26/2010	Ongoing	Com	1-Jun	31-Aug	Prohibited bottom longline for Reef FMP	75 FR 21512	622.34	Reef Fish Amendment 31
Madison-Swanson	2000	2004	6/19/2000	6/2/2004	Both	Year round		Fishing prohibited except HMS <sup>1</sup>	65 FR 31827	622.34	Reef Fish Regulatory Amendment
	2004	Ongoing	6/3/2004	Ongoing	Both	1-May	31-Oct	Fishing prohibited except surface trolling	70 FR 24532 74 FR 17603	622.34 NA	Reef Fish Amendment 21 Reef Fish Amendment 30B
	2004	Ongoing	6/3/2004	Ongoing	Both	1-Nov	30-Apr	Fishing prohibited except HMS <sup>1</sup>	70 FR 24532 74 FR 17603	622.34 NA	Reef Fish Amendment 21 Reef Fish Amendment 30B
Steamboat Lumps	2000	2004	6/19/2000	6/2/2004	Both	Year round		Fishing prohibited except HMS <sup>1</sup>	65 FR 31827	622.34	Reef Fish Regulatory Amendment
	2004	Ongoing	6/3/2004	Ongoing	Both	1-May	31-Oct	Fishing prohibited except surface trolling	70 FR 24532 74 FR 17603	622.34 NA	Reef Fish Amendment 21 Reef Fish Amendment 30B
	2004	Ongoing	6/3/2004	Ongoing	Both	1-Nov	30-Apr	Fishing prohibited except HMS <sup>1</sup>	70 FR 24532 74 FR 17603	622.34 NA	Reef Fish Amendment 21 Reef Fish Amendment 30B

The Edges	2010	Ongoing	7/24/2009	Ongoing	Both	1-Jan	30-Apr	Fishing prohibited	74 FR 30001	622.34	Reef Fish Amendment 30B Supplement
20 Fathom Break	2014	Ongoing	7/5/2013	Ongoing	Rec	1-Feb	31-Mar	Fishing for SWG prohibited <sup>2</sup>	78 FR 33259	622.34	Reef Fish Framework Action
Flower Garden	1992	Ongoing	1/17/1992	Ongoing	Both	Year round		Fishing with bottom gears prohibited <sup>3</sup>	56 FR 63634 70 FR 76216	934 622.34	Sanctuary Designation Essential Fish Habitat Amendment 3
Riley's Hump	1994	2002	2/7/1994	8/18/2002	Both	1-May	30-Jun	Fishing prohibited	59 FR 966	641.23	Reef Fish Amendment 5
Tortugas Reserves	2002	Ongoing	8/19/2002	Ongoing	Both	Year round		Fishing prohibited	67 FR 47467 70 FR 76216	635.71 622.34	Tortugas Amendment Essential Fish Habitat Amendment 3
Pulley Ridge	2006	Ongoing	1/23/2006	Ongoing	Both	Year round		Fishing with bottom gears prohibited <sup>3</sup>	70 FR 76216	622.34	Essential Fish Habitat Amendment 3
McGrail Bank	2006	Ongoing	1/23/2006	Ongoing	Both	Year round		Fishing with bottom gears prohibited <sup>3</sup>	70 FR 76216	622.34	Essential Fish Habitat Amendment 3
Stetson Bank	2006	Ongoing	1/23/2006	Ongoing	Both	Year round		Fishing with bottom gears prohibited <sup>3</sup>	70 FR 76216	622.34	Essential Fish Habitat Amendment 3

<sup>1</sup>HMS: highly migratory species (tuna species, marlin, oceanic sharks, sailfishes, and swordfish)

<sup>2</sup>SWG: shallow-water grouper (black, gag, red, red hind, rock hind, scamp, yellowfin, and yellowmouth)

<sup>3</sup>Bottom gears: Bottom longline, bottom trawl, buoy gear, pot, or trap

Harvest Restrictions – Gears\*

\*Area specific gear regulations are documented under spatial restrictions

Gear Type	First Yr In Effect	Last Yr In Effect	Effective Date	End Date	Gear/Harvesting Restrictions	Region Affected	FR Reference	FR Section	Amendment Number or Rule Type
Poison	1984	Ongoing	11/8/1984	Ongoing	Prohibited for Reef FMP	Gulf of Mexico EEZ	49 FR 39548	641.24	Original Reef Fish FMP
Explosives	1984	Ongoing	11/8/1984	Ongoing	Prohibited for Reef FMP	Gulf of Mexico EEZ	49 FR 39548	641.24	Original Reef Fish FMP
Pots and Traps	1984	1994	11/23/1984	2/6/1994	Established fish trap permit	Gulf of Mexico EEZ	49 FR 39548	641.4	Original Reef Fish FMP
	1984	1990	11/23/1984	2/20/1990	Set max number of traps fish by a vessel at 200	Gulf of Mexico EEZ	49 FR 39548	641.25	Original Reef Fish FMP
	1990	1994	2/21/1990	2/6/1994	Set max number of traps fish by a vessel at 100	Gulf of Mexico EEZ	55 FR 2078	641.22	Reef Fish Amendment 1
	1994	1997	2/7/1994	2/7/1997	Moratorium on additional commercial trap permits	Gulf of Mexico EEZ	59 FR 966	641.4	Reef Fish Amendment 5
	1997	2007	3/25/1997	2/7/2007	Phase out of fish traps begins	Gulf of Mexico EEZ	62 FR 13983	622.4	Reef Fish Amendment 14
	1997	2007	1/29/1988	2/7/2007	Prohibited harvest of reef fish from traps other than permitted reef fish, stone crab, or spiny lobster traps.	Gulf of Mexico EEZ	62 FR 67714	622.39	Reef Fish Amendment 15
All	2007	Ongoing	2/8/2007	Ongoing	Traps prohibited	Gulf of Mexico EEZ	62 FR 13983	622.31	Reef Fish Amendment 14
	1992	1995	5/8/1992	12/31/1995	Moratorium on commercial permits for Reef FMP	Gulf of Mexico EEZ	59 FR 11914 59 FR 39301	641.4 641.4	Reef Fish Amendment 4 Reef Fish Amendment 9
	1994	Ongoing	2/7/1994	Ongoing	Finfish must have head and fins intact through landing, can be eviscerated, gilled, and scaled but must otherwise be whole (HMS and bait exceptions)	Gulf of Mexico EEZ	59 FR 966	641.21	Reef Fish Amendment 5
	1996	2005	7/1/1996	12/31/2005	Moratorium on commercial permits for Gulf reef fish	Gulf of Mexico EEZ	61 FR 34930 65 FR 41016	622.4 622.4	Interim Rule Reef Fish Amendment 17
	2006	Ongoing	9/8/2006	Ongoing	Use of Gulf reef fish as bait prohibited <sup>1</sup>	Gulf of Mexico EEZ	71 FR 45428	622.31	Reef Fish Amendment 18A
Vertical Line	2008	Ongoing	6/1/2008	Ongoing	Requires non-stainless steel circle hooks and dehooking devices	Gulf of Mexico EEZ	74 FR 5117	322.41	Reef Fish Amendment 27
	2008	2013	6/1/2008	9/3/2013	Requires venting tools	Gulf of Mexico EEZ	74 FR 5117 78 FR 46820	322.41 NA	Reef Fish Amendment 27 Framework Action
Bottom Longline	2010	Ongoing	5/26/2010	Ongoing	Limited to 1,000 hooks of which no more than 750 hooks are rigged for fishing or fished	Gulf of Mexico EEZ	75 FR 21512	622.34	Reef Fish Amendment 31

<sup>1</sup>Except when, purchased from a fish processor, filleted carcasses may be used as bait crab and lobster traps.

Recreational Quota Information – Red Grouper

<b>First Yr In Effect</b>	<b>Last YR In Effect</b>	<b>Effective Date</b>	<b>End Date</b>	<b>ACL</b>	<b>ACT</b>	<b>Units</b>	<b>Region Affected</b>	<b>FR Reference</b>	<b>FR Section</b>	<b>Amendment Number or Rule Type</b>
2009	2010	5/18/2009	12/31/2010	1.85	1.02	mp gw	Gulf of Mexico EEZ	74 FR 17603	622.49	Reef Fish Amendment 30B
2011	2011	11/2/2011	12/31/2011		1.65	mp gw	Gulf of Mexico EEZ	76 FR 67618		Reef Fish Regulatory Amendment
2012	2015	3/12/2012	12/31/2015	1.9	1.73	mp gw	Gulf of Mexico EEZ	77 FR 6988	622.49	Reef Fish Amendment 32
2016	Ongoing	10/12/2016	Ongoing	2.58	2.37	mp gw	Gulf of Mexico EEZ	81 FR 70365	622.41	Reef Fish Framework Action

Commercial Quota Information

First Yr In Effect	Last YR In Effect	Effective Date	End Date	Species Affected	Quota	ACL	Units	Region Affected	FR Reference	FR Section	Amendment Number or Rule Type
1990	1991	2/21/1990	12/31/1991	All Groupers Excluding DWG <sup>1</sup> and Goliath	9.2		mp ww	Gulf of Mexico EEZ	55FR 2078	641.25	Reef Fish Amendment 1
1992	2003	6/22/1992	12/31/2003	All Groupers Including Scamp Excluding DWG <sup>1</sup> and Goliath	9.8		mp ww	Gulf of Mexico EEZ	57 FR 21752	641.25	Reef Fish Regulatory Amendment
2004	2008	7/15/2004	12/31/2008	All Groupers Including Scamp Excluding DWG <sup>1</sup> , Goliath, and Nassau	8.8		mp gw	Gulf of Mexico EEZ	69 FR 33315	622.42	Secretarial Amendment 1
2009	2009	5/18/2009	12/31/2009	SWG <sup>2</sup>	7.48		mp gw	Gulf of Mexico EEZ	74 FR 17603	622.42	Reef Fish Amendment 30B
2010	2010	5/18/2009	12/31/2010	SWG <sup>2</sup>	7.57		mp gw	Gulf of Mexico EEZ	74 FR 17603	622.42	Reef Fish Amendment 30B
2011	2011	11/2/2011	12/31/2011	SWG <sup>2</sup>	6.07		mp gw	Gulf of Mexico EEZ	76 FR 67618	622.42	Reef Fish Regulatory Amendment
2012	2012	3/12/2012	12/31/2012	SWG <sup>2</sup>	6.347	8.04	mp gw	Gulf of Mexico EEZ	77 FR 6988	622.49	Reef Fish Amendment 32
2013	2013	3/12/2012	12/31/2013	SWG <sup>2</sup>	6.648	8.04	mp gw	Gulf of Mexico EEZ	77 FR 6988	622.49	Reef Fish Amendment 32
2014	2014	1/7/2015	12/31/2014	Other SWG <sup>3</sup>	0.523	0.545	mp gw	Gulf of Mexico EEZ	79 FR 72556	622.39	Reef Fish Framework Action
2015	Ongoing	1/7/2015	Ongoing	Other SWG <sup>3</sup>	0.525	0.547	mp gw	Gulf of Mexico EEZ	79 FR 72556	622.39	Reef Fish Framework Action
2004	2008	7/15/2004	12/31/2008	Red Grouper	5.31		mp gw	Gulf of Mexico EEZ	69 FR 33315	622.42	Secretarial Amendment 1
2009	2010	5/18/2009	12/31/2010	Red Grouper	5.75	5.87	mp gw	Gulf of Mexico EEZ	74 FR 17603	622.49	Reef Fish Amendment 30B
2011	2011	1/1/2011	11/1/2011	Red Grouper	4.32		mp gw	Gulf of Mexico EEZ	75 FR 74656	622.42	Reef Fish Regulatory Amendment
2011	2011	11/2/2011	12/31/2011	Red Grouper	5.23		mp gw	Gulf of Mexico EEZ	76 FR 67618	622.42	Reef Fish Regulatory Amendment
2012	2012	11/2/2011	12/31/2012	Red Grouper	5.37		mp gw	Gulf of Mexico EEZ	76 FR 67618	622.42	Reef Fish Regulatory Amendment
2012	2015	3/12/2012	12/31/2015	Red Grouper		6.03	mp gw	Gulf of Mexico EEZ	77 FR 6988	622.49	Reef Fish Amendment 32
2013	2013	11/2/2011	12/31/2013	Red Grouper	5.53		mp gw	Gulf of Mexico EEZ	76 FR 67618	622.42	Reef Fish Regulatory Amendment
2014	2014	11/2/2011	12/31/2014	Red Grouper	5.63		mp gw	Gulf of Mexico EEZ	76 FR 67618	622.42	Reef Fish Regulatory Amendment
2015	2015	11/2/2011	12/31/2015	Red Grouper	5.72		mp gw	Gulf of Mexico EEZ	76 FR 67618	622.42	Reef Fish Regulatory Amendment
2016	Ongoing	10/12/2016	Ongoing	Red Grouper	7.78	8.19	mp gw	Gulf of Mexico EEZ	81 FR 70365	622.41	Reef Fish Framework Action

<sup>1</sup>DWG: deep-water grouper (misty grouper, snowy grouper, yellowedge grouper, warsaw grouper)

<sup>2</sup>SWG: shallow-water grouper (black, gag, red, red hind, rock hind, scamp, yellowfin, and yellowmouth)

<sup>3</sup>Other SWG: other shallow-water grouper (black grouper, scamp, yellowmouth grouper, yellowfin grouper)

### 3 ASSESSMENT HISTORY AND REVIEW

Pre-SEDAR assessments of Gulf of Mexico resources were typically prepared by scientists of the Southeast Fisheries Science Center and reviewed by the Gulf of Mexico Fishery Management Council (GMFMC) Reef Fish Stock Assessment Panel (RFSAP) and Science and Statistics Committee (SSC). Excerpts from RFSAP reports addressing previous assessments are compiled into a single document for convenience (SEDAR12-RW01). Previous stock assessments referenced below are provided for reference and organized under the SEDAR 12 research document listing as follows: Goodyear and Schirripa, 1991 (SEDAR12-RD04), Goodyear and Schirripa, 1993 (SEDAR12-RD07), Schirripa et al, 1999 (SEDAR12-RD05), and SEFSC, 2001 (SEDAR12-RD02).

The first documented assessment of the Gulf of Mexico stock of red grouper is Goodyear and Schirripa, 1991 (SEFSC cont. MIA-90/91-86). This assessment compiled available life history and fishery data from the 1960's through 1990, evaluated and interpreted trends in data sources, evaluated recent regulatory changes, and estimated mortality through catch curve analysis. Some of the challenges identified included difficulty evaluating SPR for a hermaphroditic species with limited life history research, interpretation of growth models based on competing data sources, estimation of release and natural mortality, inadequate biological sampling of grouper fisheries, a lack of direct age observations from the fisheries, and uncertainties in landings statistics due to incomplete and imprecise reporting.

Published natural mortality estimates evaluated in the 1991 assessment ranged from 0.17 to 0.32; the assessment adopted a natural mortality value of  $M=0.2$  with little justification while acknowledging that it could be excessive given the abundance of older ages in the population.

Discard losses are identified as an increasing challenge to stock productivity. Although the discard mortality rate is uncertain, the high number of discards resulting from recent size limit changes raised concern. The authors suggested that eliminating the minimum size limit could increase yield per recruit for even moderate discard mortality assumptions.

Implementation of an 18" minimum size limit by Florida in 1986 had little perceived impact of commercial fisheries but led to an initial decline in recreational harvest followed by recovery as the fishery moved from near shore state waters to offshore federal (EEZ) waters. Additional regulations implemented in 1990 included an increase in minimum size to 20", a 5 fish recreational creel restriction, and a commercial quota intended to reduce commercial exploitation 20%. Fishery changes attributed to these actions include a 70% decline in recreational harvest numbers, a 20% decline in commercial harvest (exacerbated by premature fishery closure), and notable shifts in harvest length compositions.

Because fishery age samples are lacking, growth models were used to assign catches by length to age classes for use in the catch curve analyses. Two alternative catch-age matrices were developed to address differences in estimated growth rate observed between a study conducted in the mid 1960's and another in the late 1980's. It was not known whether the growth disparity was legitimate or simply reflected methodological differences between separate studies, although several hypothesis enabling a change in population growth were proposed.

Upon review of this assessment in October, 1991, the GMFMC RFSAP endorsed status estimates based on recent growth data and biological references based on yield per recruit analyses. Fishing mortality rates were stated as being between  $F_{0.1}$  and  $F_{max}$  depending on the assumed discard mortality rate. Estimated SPR exceeded the 20% SPR limit then in effect for all discard mortality assumptions.

The next assessment, also prepared by Goodyear and Schirripa, was completed in 1993 with through 1992. Enhancements in this version included inclusion of landings and effort data from the Cuban fleets operating off the west coast of Florida, 1950-1976; development of CPUE indices for several fisheries based on the logbook program introduced in 1990; and development of a VPA analysis. There was no resolution of the growth disparity and only minor improvement in fishery dependent sampling. Growth modeling was again used to develop catches at age. Results of the catch curves and VPA analyses remained quite variable when uncertainties in growth and age assignment were considered, although no notable changes in stock status were suggested by this assessment. The RFSAP reviewed this assessment in August 1993 and accepted the findings.

In 1994 the GMFMC RFSAP reviewed two detailed analyses of the red grouper growth disparity and determined that differences were related to sampling (Goodyear 1994 and undated). This work led to acknowledgement that significant bias is introduced into stock assessments when catch ages are determined from growth models based on data from length-stratified sampling, size-selective gears, or fisheries restricted by minimum sizes. Although it was believed that sampling bias could be addressed, bias introduced by the minimum size could not be removed and therefore the results of previous red grouper assessments were deemed invalid at this time.

Major revisions were included in the next assessment, prepared by Schirripa, Legault, and Ortiz in 1999 including data through 1997. The catch time series was extended, with landings statistics evaluated back to the 1940's and acknowledgement of a fishery back to at least 1880.

Recreational landings for 1940-1981 were inferred through regression with population to enable estimation of total harvest removals prior to inception of MRFSS. Additional indices were developed, including headboat CPUE, tag-recapture study CPUE, and two fishery-independent indices provided through SEAMAP beginning in 1992. Growth models were evaluated further and a probabilistic approach for converting catch at length to catch at age was incorporated. Two assessment approaches were considered: a production model and a catch-age model.

Considerable effort was devoted to evaluating growth models and trends in growth rates by comparing newly available capture-recapture growth estimates with those obtained through traditional back-calculation from hard parts. The authors concluded that both approaches were useful in estimating growth parameters and noted that consistency in estimates between the two methods suggested that estimated values were reliable.

Both production models (ASPIC) and forward projection catch-age models (ASAP) were developed to evaluate stock status. Neither of the previous assessment approaches (catch curves and VPA) were updated in this assessment. Ages were determined for the forward projecting model through the Goodyear (1995) probabilistic approach that also enables estimation of discards.

The production model performed reasonably well, but lacked ability to address perceived changes in fishery characteristics (e.g., catchability and selectivity) over time and did not allow inclusion of available information on size or age of capture. The catch-age model provided greater flexibility and incorporated more available data, but was highly parameterized and sensitive to steepness and data series duration. Both models suggested that the stock was overfished and overfishing was occurring in 1997. Both models indicated that fishing mortality was increasing while both SSB and recruitment were decreasing, and that peak abundance occurred sometime during the 1940's or 1950's.

The RFSAP reviewed the assessment in September 1999 and accepted the methods and results. Management recommendations were based on the ASAP model incorporating the long time series (1940-1997). The stock was considered overfished and overfishing was occurring in the terminal year (1997).

The sequence of events becomes less clear after this point. The December 2000 RFSAP report indicates that the RFSAP questioned aspects of the assessment following the September 1999 meeting noted above, setting off a chain of analyses and reviews extending over several years. In response to concerns about the assessment, NMFS/SEFSC prepared additional analyses that were presented to the RFSAP in August 2000. This led to further requests to conduct an extensive suite of additional analyses evaluating a range of alternative assumptions, culminating in a RFSAP meeting in December 2000 to review the results of the August recommendations. The RFSAP based its December 2000 recommendations on runs configured with a short landings time series, updated 1998-99 harvest data, a 33% release mortality rate for the longline fishery, longline discards estimated through the probabilistic approach, and steepness values of 0.7 and 0.8. There was no change in the estimated stock status despite these efforts. According to estimates from the chose configuration, the stock was both overfished and overfishing in the terminal year 1997 .



The basic configuration agreed to by the RFSAP in December 2000 was updated by NMFS/SEFSC in 2002, including data through 2001. New data sources included additional age and growth information provided by a 1992-2001 life history study and subsequent improved catch-age allocations, and updated fecundity information based on 1992-2001 sampling.

The RFSAP reviewed the updated assessment in September, 2002. The panel based management advice on assessment configurations including the newly available life history information. Steepness values of 0.7 and 0.8 were used to develop a range for management parameter estimates, with a caveat that the 0.8 value was well above both the estimated value (0.68) and expected values for species of similar life history. It was believed at this time that the stock was showing some signs of recovery, as the stock was no longer overfished and runs based on steepness 0.8 suggesting that overfishing was no longer occurring. The panel noted that increases in catch in the terminal years may be the result of recent strong year classes while acknowledging a lack of information available at the time to evaluate such a hypothesis. The panel also commented that recent increases in abundance and thus biomass appeared the result of recent increased recruitment.

In 2006, red grouper was assessed under the umbrella of the SEDAR process (SEDAR 2006). Two models were considered. The first was a model configured using the age-structured assessment program (ASAP, Legault and Restrepo 1998) and the second was a production model. The production model was ultimately rejected due to a lack of convergence; therefore, the ASAP model was used to evaluate stock status and provide management advice. The assessment time-series started in 1986 and ended in 2005. The age-structure of the population was assumed to start with age-1 recruits and the terminal age bin, age-20, represented a plus group. The main data inputs for the ASAP model included indices of abundance (commercial handline, commercial longline, MRFSS recreational, headboat survey (1986 – 1990, 18" TL size limit), headboat survey (1990 – 2005, 20" TL size limit), and SEAMAP video survey), catch-at-age, discards-at-age, catch in weight, and discards in weight. The catchabilities of the fishery-dependent indices were assumed to increase by 2% annually. Catch-at-age and discards-at-age were modeled using the Goodyear approach (Goodyear 1997). The results of the 2006 stock assessment indicated that the stock was not be overfished ( $SSB/SSB_{MSY} = 1.27$ ) and was not experiencing overfishing ( $F/F_{MSY} = 0.73$ ).

The 2006 assessment was revisited in 2009 as an update assessment. The update assessment time-series started in 1986 and was extended by three years, ending in 2008. The basic model structure and data inputs were similar to the 2006 assessment. The main difference in the data inputs was the inclusion of observed discard lengths from the recreational (2005-2007) and commercial longline and handline fleets (2006-2008) that were converted to ages. The 2006 model was changed to include an episodic red tide mortality event in 2005 and no longer assumed an annually increasing catchability in the fishery-dependent indices. The results of the

update assessment indicated that the stock was not overfished in 2008 and was not experiencing overfishing.

## References

- Goodyear, C. P. and M. J. Schirripa. 1991. The red grouper fishery of the Gulf of Mexico. Southeast Fisheries Science Center, Miami, FL. Miami Laboratory contribution MIA 90/91-86. 80 pp.
- Goodyear, C. P. and M. J. Schirripa. 1993. The red grouper fishery of the Gulf of Mexico. Southeast Fisheries Science Center, Miami, FL. Miami Laboratory contribution MIA 92/93-75. 122 pp.
- Goodyear, C. P. 1994. Biological reference points for red grouper: uncertainty about growth. Southeast Fisheries Science Center, Miami, FL. Miami Laboratory contribution MIA 93/94-60. 26 pp.
- Goodyear C. P. Undated. Red grouper mean size at age: an evaluation of sampling strategies using simulated data. Unpublished manuscript, Southeast Fisheries Science Center, Miami, FL. 8 pp.
- Goodyear C. P. 1995. Mean size at age: An evaluation of sampling strategies with simulated red grouper data. *Transactions of the American Fisheries Society* 124: 746-755.
- Legault, C. M., Restrepo, V.R. 1999. A flexible forward age-structured assessment program. *ICCAT Coll. Vol. Sci. Pap.* 49(2): 246-253.
- SEDAR. 2006. SEDAR stock assessment report: Gulf of Mexico Red Grouper. SEDAR, Charleston, SC. SEDAR 12-SAR1.
- SEDAR. 2007. Excerpts from Gulf of Mexico Fishery Management Council Reef Fish Stock Assessment Panel reports addressing red grouper, 1999-2002. SEDAR, Charleston, SC. SEDAR12-RW01.
- SEDAR. 2009. Stock assessment of red grouper in the Gulf of Mexico – SEDAR update assessment. SEDAR, Charleston, SC.
- SEFSC. 2002. Draft status of red grouper in United States waters of the Gulf of Mexico during 1986 - 2001. Southeast Fisheries Science Center, Miami, FL. Sustainable Fisheries Division contribution SFD 01/02-175rev.
- Schirripa, M. J., C. M. Legault, and M. Ortiz. 1999. The red grouper fishery of the Gulf of Mexico: assessment 3.0. Southeast Fisheries Science Center, Miami, FL. Sustainable Fisheries Division Contribution SFD 98/99-56. 57 pp.

#### 4 REGIONAL MAPS

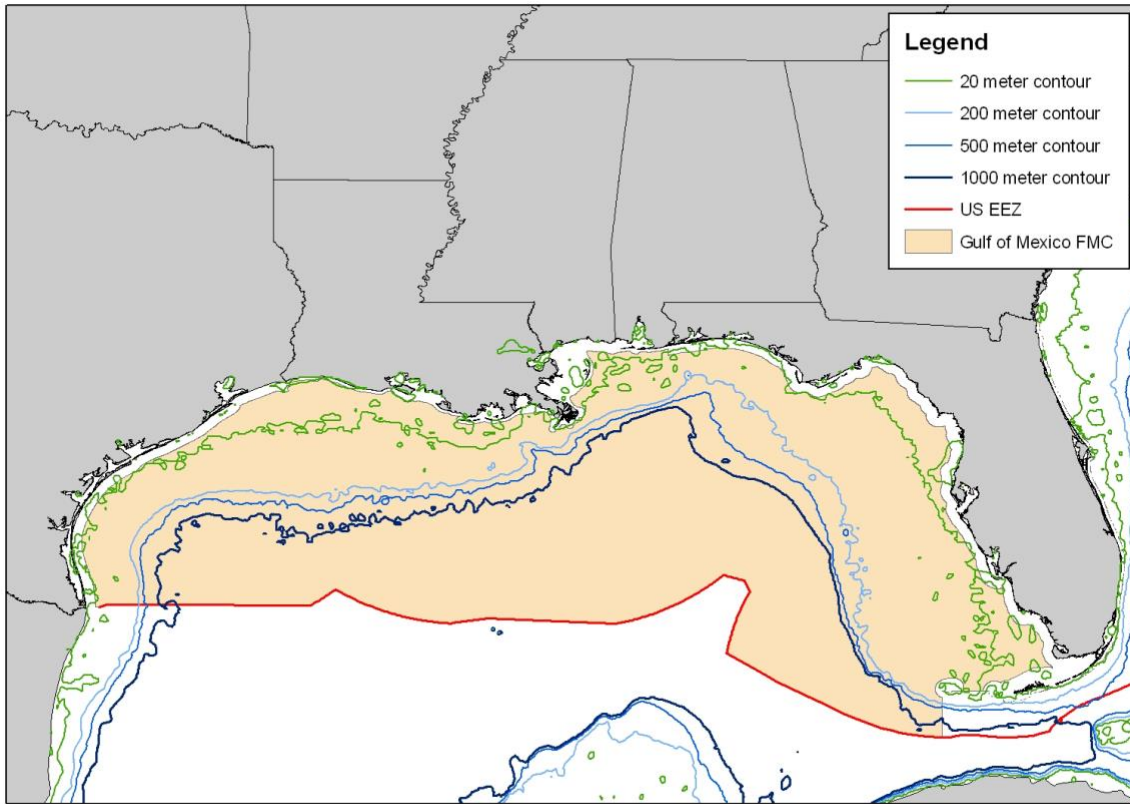


Figure 4.1 Southeast Region including Council and EEZ Boundaries.

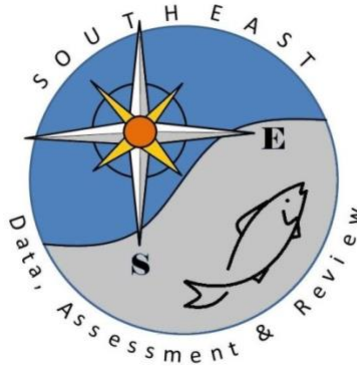
#### 5 SEDAR ABBREVIATIONS

ABC	Acceptable Biological Catch
ACCSP	Atlantic Coastal Cooperative Statistics Program
ADMB	AD Model Builder software program
ALS	Accumulated Landings System; SEFSC fisheries data collection program
AMRD	Alabama Marine Resources Division
ASMFC	Atlantic States Marine Fisheries Commission
B	stock biomass level
BAM	Beaufort Assessment Model

BMSY	value of B capable of producing MSY on a continuing basis
CFMC	Caribbean Fishery Management Council
CIE	Center for Independent Experts
CPUE	catch per unit of effort
EEZ	exclusive economic zone
F	fishing mortality (instantaneous)
FMSY	fishing mortality to produce MSY under equilibrium conditions
FOY	fishing mortality rate to produce Optimum Yield under equilibrium
FXX% SPR	fishing mortality rate that will result in retaining XX% of the maximum spawning production under equilibrium conditions
FMAX	fishing mortality that maximizes the average weight yield per fish recruited to the fishery
F0	a fishing mortality close to, but slightly less than, Fmax
FL FWCC	Florida Fish and Wildlife Conservation Commission
FWRI	(State of) Florida Fish and Wildlife Research Institute
GA DNR	Georgia Department of Natural Resources
GLM	general linear model
GMFMC	Gulf of Mexico Fishery Management Council
GSMFC	Gulf States Marine Fisheries Commission
GULF FIN	GSMFC Fisheries Information Network
HMS	Highly Migratory Species
LDWF	Louisiana Department of Wildlife and Fisheries
M	natural mortality (instantaneous)
MARMAP	Marine Resources Monitoring, Assessment, and Prediction
MDMR	Mississippi Department of Marine Resources
MFMT	maximum fishing mortality threshold, a value of F above which overfishing is deemed to be occurring
MRFSS	Marine Recreational Fisheries Statistics Survey
MRIP	Marine Recreational Information Program
MSST	minimum stock size threshold, a value of B below which the stock is deemed to be overfished

MSY	maximum sustainable yield
NC DMF	North Carolina Division of Marine Fisheries
NMFS	National Marine Fisheries Service
NOAA	National Oceanographic and Atmospheric Administration
OY	optimum yield
SAFMC	South Atlantic Fishery Management Council
SAS	Statistical Analysis Software, SAS Corporation
SC DNR	South Carolina Department of Natural Resources
SEAMAP	Southeast Area Monitoring and Assessment Program
SEDAR	Southeast Data, Assessment and Review
SEFIS	Southeast Fishery-Independent Survey
SEFSC	Fisheries Southeast Fisheries Science Center, National Marine Fisheries Service
SERO	Fisheries Southeast Regional Office, National Marine Fisheries Service
SPR	spawning potential ratio, stock biomass relative to an unfished state of the stock
SSB	Spawning Stock Biomass
SS	Stock Synthesis
SSC	Science and Statistics Committee
TIP	Trip Incident Program; biological data collection program of the SEFSC and Southeast States.
TPWD	Texas Parks and Wildlife Department
Z	total mortality, the sum of M and F

# SEDAR



Southeast Data, Assessment, and Review

---

SEDAR 61

Gulf of Mexico Red Grouper

SECTION II: Assessment Process Report

**July 2019**

SEDAR  
4055 Faber Place Drive, Suite 201  
North Charleston, SC 29405

**Table of Contents**

1. INTRODUCTION ..... 4

**1.1 Workshop Time and Place ..... 4**

**1.2 Terms of Reference ..... 4**

**1.3 List of Participants ..... 5**

**1.4 List of Assessment Workshop Working Papers and Reference Documents..... 7**

2. INPUT DATA..... 10

**2.1 Stock Structure and Management Unit ..... 10**

**2.2 Life History Parameters ..... 10**

        2.2.1 Conversion Factors ..... 10

        2.2.2 Age and Growth..... 10

        2.2.3 Natural Mortality ..... 11

        2.2.4 Discard Mortality..... 11

        2.2.5 Reproduction ..... 12

            2.2.5.1 Maturity ..... 12

            2.2.5.2 Sexual Transition..... 12

            2.2.5.3 Fecundity ..... 13

**2.3 Commercial Fishery Data..... 14**

        2.3.1 Landings ..... 14

        2.3.2 Size and Age Composition of Landings ..... 14

        2.3.3 Discards ..... 15

        2.3.4 Size Composition of Discards ..... 16

        2.3.5 Catch-per-unit-effort (CPUE)..... 17

**2.4 Recreational Fishery Data ..... 17**

        2.4.1 Landings ..... 19

        2.4.2 Size and Age Composition of Landings ..... 19

        2.4.3 Discards ..... 22

        2.4.4 Size Composition of Discards ..... 23

        2.4.5 Catch-per-unit-effort (CPUE)..... 23

**2.5 Fishery-Independent Surveys..... 24**

        2.5.1 SEAMAP Summer Groundfish Survey ..... 25

        2.5.2 NMFS Bottom Longline Survey..... 26

        2.5.3 Combined Video Survey ..... 26

        2.5.4 FWRI Hook and Line Repetitive Time Drop Survey ..... 28

**2.6 Environmental Considerations ..... 29**

    2.6.1 Index of red tide severity ..... 29

    2.6.2 Index of red tide mortality – New Data ..... 30

    2.6.3 Treatment of the 2014 and 2015 Red Tide Events ..... 31

**2.7 Contributions from Stakeholders ..... 31**

**2.8 References ..... 32**

**2.9 Tables..... 35**

**2.10 Figures ..... 83**

**3. STOCK ASSESSMENT METHODS..... 115**

**3.1 Overview ..... 115**

**3.2 Data Sources ..... 116**

**3.3 Model Configuration..... 117**

        3.3.1 Life History..... 118

        3.3.2 Recruitment Dynamics ..... 119

        3.3.3 Starting Conditions ..... 120

        3.3.4 Fleet Structure..... 121

        3.3.5 Catch-per-unit-effort (CPUE) Indices ..... 121

        3.3.6 Surveys ..... 121

        3.3.7 Selectivity ..... 122

        3.3.8 Retention..... 123

        3.3.9 Discards ..... 124

        3.3.10 Composition data and aging error ..... 125

        3.3.11 Accounting for Mortality due to Red Tide ..... 125

**3.4 Maximum Likelihood and Uncertainty ..... 126**

        3.4.1 Error Structure ..... 126

        3.4.2 Data Weighting..... 127

        3.4.3 Uncertainty Estimation..... 128

        3.4.4 Estimated Parameters ..... 128

**3.5 Model Diagnostics ..... 128**

        3.5.1 Residual Analysis ..... 129

        3.5.2 Correlation Analysis ..... 129

        3.5.3 Profile Likelihood..... 129

        3.5.4 Bootstrap..... 129

        3.5.5 Jitter Analysis ..... 130



3.5.6 Retrospective Analysis ..... 130

3.5.7 Jack-knife Analysis on Indices of Abundance ..... 131

3.5.8 Continuity Model and Model Bridging Exercise ..... 131

3.5.9 Sensitivity Runs ..... 132

4. MODEL RESULTS ..... 133

**4.1 Landings ..... 133**

**4.2 Discards ..... 133**

**4.3 Indices ..... 134**

**4.4 Size Composition ..... 135**

**4.5 Age Composition ..... 137**

**4.6 Fishery Selectivity and Retention ..... 138**

**4.7 Recruitment ..... 140**

**4.8 Red Tide ..... 140**

**4.9 Population Trajectories ..... 141**

**4.10 Fishing Mortality ..... 141**

**4.11 Measures of Uncertainty ..... 142**

**4.12 Diagnostic Runs ..... 142**

4.12.1 Profile Likelihoods ..... 142

4.12.2 Bootstrap Analysis ..... 143

4.12.3 Retrospective Analysis ..... 144

4.12.4 Jitter Analysis ..... 144

4.12.5 Index Jack-knife Analysis ..... 144

4.12.6 Continuity Model Comparison ..... 144

4.12.7 Sensitivity Model Runs ..... 146

5. REFERENCE POINTS ..... 147

**5.1 Methods ..... 147**

**5.2 Treatment of 2018 Red Tide Event ..... 149**

**5.3 Stock Status ..... 149**

**5.4 Overfishing Limits ..... 150**

**5.5 Other Projection Runs ..... 151**

6. DISCUSSION ..... 151

**6.1 Research Recommendations ..... 154**

7. ACKNOWLEDGEMENTS ..... 156

8. REFERENCES ..... 157

9. TABLES .....	160
10. FIGURES .....	181

## 1. INTRODUCTION

This document summarizes the SEDAR61 standard assessment of Red Grouper in the U.S. Gulf of Mexico using updated data inputs through 2017 as implemented in the Stock Synthesis modeling framework (Methot and Wetzel 2013). The standard assessment approach updates the SEDAR42 benchmark assessment, but allows for updated methodology and new data. The SEDAR61 Base Model has changed considerably from the SEDAR42 Final Model (i.e., the SEDAR42 model used to provide management advice [RW2 in SEDAR42 2015]), both in terms of the development of data streams and model configuration. Major advancements in methodology and/or additional data collection led to revised model inputs and data streams including age and growth (and derived natural mortality), fecundity-at-age, commercial discards, recreational inputs (landings, discards, catch-per-unit-effort (CPUE) and age composition), relative abundance and size composition for the Combined Video Survey, and input sample sizes for both size and age composition data. In addition, a new fishery-independent index of relative abundance and associated size composition were provided by the FWRI Hook and Line Repetitive Time Drop Survey. Regarding model configuration, major changes were made to improve model stability and diagnostics, namely starting the model in 1986 rather than 1993, approximating initial equilibrium catches using the average catch of the first five years of the time series, reconfiguring how the red tide pseudo-fishing fleet operates, exploring size-based selectivity for the fishing fleets, revising parameterization of retention, and iterative reweighting approaches to data weighting.

### 1.1 Workshop Time and Place

The SEDAR61 Gulf of Mexico Red Grouper Assessment Process was conducted via a series of webinars held between November 2018 and July 2019, as well as an in-person workshop, held September 11 – 13, 2018 in St. Petersburg, Florida.

### 1.2 Terms of Reference

The terms of reference approved by the Gulf of Mexico Fishery Management Council are listed below.

- 1) Update the approved SEDAR42 Gulf of Mexico Red Grouper base model, with data through 2017. Provide a model consistent with the previous assessment configuration to incorporate and evaluate any changes allowed for during this assessment.
- 2) Evaluate and document the following specific changes in input data or deviations from the benchmark model previous assessment model.

- A) Review existing methods for deriving discard numbers and discard rates and improve methods as appropriate (see **Section 2.3.3**)
  - B) Explore the effect of the IFQ program on commercial CPUE, and the sensitivity of model results to plausible alternative commercial CPUE series (see **Sections 2.3.5 and 4.12.7**)
  - C) Review analytical methods for the combined video index from the FWRI, Pascagoula, and Panama City video surveys (see **Section 2.5.3**)
  - D) Explore the potential effects of red tide with consideration of past red tide events and those of 2014 and 2015 (see **Sections 2.6 and 4.12.7**)
  - E) Reconsider the start year of the assessment model (see **Sections 3.3.3 and 4.12.6**)
  - F) Evaluate size-based selectivity (see **Sections 3.3.7 and 4.6**)
  - G) Investigate the use of new fishery-independent hook-gear survey data collected by FWC (see **Section 2.5.4**)
- 3) Document any revisions or corrections made to the model and input datasets, and provide updated input data tables. Provide commercial and recreational landings and discards in numbers and weight (pounds).
  - 4) Update model parameter estimates and their variances, model uncertainties, and estimates of stock status and management benchmarks. In addition to the base model, conduct sensitivity analyses to address uncertainty in data inputs and model configuration and consider runs that represent plausible, alternate states of nature.
  - 5) Project future stock conditions regardless of the status of the stock. Develop rebuilding schedules, if warranted. Provide the estimated generation time for each unit stock. Stock projections shall be developed in accordance with the following:

Scenarios to Evaluate (preliminary, to be modified as appropriate):

1. Landings fixed at 2017 target
  2.  $F_{OY} = 75\% F_{MSY}$  (project when OY will be achieved)
  3. Project  $F_{Rebuild}$  (if necessary)
  4.  $F = 0$  (if necessary)
  5. Equilibrium yield at  $F_{MSY}$
- 6) Develop a stock assessment report to address these TORs and fully document the input data, methods, and results.

### 1.3 List of Participants

#### Panelists

Skyler Sagarese (Lead analyst)..... NMFS Miami  
 Steve Brown.....FWC, Cedar Key  
 Mary Christman ..... SSC  
 Chris Gardner ..... NMFS Panama City

Bob Gill.....	SSC
Walter Ingram .....	NMFS Pascagoula
Dominique Lazarre .....	FWC, St. Pete
Linda Lombardi .....	NMFS Panama City
Kevin McCarthy.....	NMFS Miami
Will Patterson.....	SSC/UF
Adyan Rios.....	NMFS Miami
Allison Shideler .....	UM-CIMAS, Miami
Matthew Smith.....	NMFS Miami
John Walter .....	NMFS Miami
Beth Wrege .....	NMFS Miami

**Appointed Observers**

Mike Colby .....	Clearwater Marine Association
Jason Delacruz .....	Wild Seafood
Mark Hubbard.....	Hubbard’s Marina

**Attendees**

Sue Barbieri .....	FWC
Ben Bateman.....	Stakeholder
Heather Christiansen.....	FWC
Michael Drexler .....	Ocean Conservancy
Ben Duffin .....	FWC
Rachel Germeroth.....	FWC
Brad Gorst.....	Gulf Streams Fishing Vessels
Dylan Hubbard.....	Hubbard’s Marina
Mady Jedland .....	FWC
Sean Keenan.....	FWC
Kate Overly .....	NMFS Panama City
Ashley Pacicco.....	NMFS Panama City
Sheri Parks .....	FWC
Jeff Pulver .....	NMFS SERO
Dylan Sinnickson.....	UF
Ted Switzer .....	FWC
Kevin Thompson.....	FWC
Kelly Vasbinder .....	USF-CMS
Julie Vecchio.....	USF-CMS

**Staff**

Julie Neer .....	SEDAR
Emily Muehlstein.....	GMFMC Staff
Ryan Rindone.....	GMFMC Staff
Charlotte Schiaffo .....	GMFMC Staff

**Webinar Attendees**

Eric Brazer ..... Shareholders Alliance  
 Shannon Cass-Calay ..... NMFS Miami  
 Matt Campbell ..... NMFS Pascagoula  
 Ching-Ping Chih ..... NMFS Miami  
 Dave Chagaris ..... UF  
 Nancie Cummings ..... NMFS Miami  
 Martin Fisher ..... Stakeholder  
 Gary Fitzhugh ..... NMFS Panama City  
 Kelly Fitzpatrick ..... NMFS Beaufort  
 Alisha Gray DiLeone ..... NMFS  
 Doug Gregory ..... SSC  
 Jeff Isely ..... NMFS Miami  
 Mandy Karnauskas ..... NMFS Miami  
 Stephen Maisel ..... Maisel Marine Inc.  
 Michelle Masi ..... NMFS Galveston  
 Vivian Matter ..... NMFS Miami  
 Refik Orhun ..... NMFS Miami  
 Adam Pollack ..... NMFS Pascagoula  
 Nick Ruland ..... Stakeholder  
 Beverly Sauls ..... FWC

**1.4 List of Assessment Workshop Working Papers and Reference Documents**

Document #	Title	Authors	Date Submitted
<b>Documents Prepared for the Assessment Process</b>			
SEDAR61-WP-01	Red grouper <i>Epinephelus morio</i> Findings from the NMFS Panama City Laboratory Camera & Trap Fishery-Independent Survey 2004-2017	C.L. Gardner and K.E. Overly	16 August 2018
SEDAR61-WP-02	An Index of Relative Abundance for Red Grouper Captured During the NMFS Bottom Longline Survey in the Northern Gulf of Mexico	Adam G. Pollack, David S. Hanisko and G. Walter Ingram, Jr.	17 August 2018
SEDAR61-WP-03	Indices of abundance for Red Grouper ( <i>Epinephelus morio</i> ) using combined data from three independent video surveys	Kevin A. Thompson, Theodore S. Switzer, Mary C. Christman, Sean F. Keenan, Christopher Gardner, Matt Campbell	17 August 2018 Updated: 13 November 2018

SEDAR61-WP-04	FWRI data summary for Gulf of Mexico red grouper maturity, sexual transition 2014-2017	S. Lowerre-Barbieri, L. Crabtree, H. Staley, and T. Switzer	17 August 2018
SEDAR61-WP-05	Standardized Catch Rates of Red Grouper ( <i>Epinephelus morio</i> ) from the U.S. Headboat Fishery in the Gulf of Mexico, 1986-2017	Skyler Sagarese and Adyan Rios	17 August 2018
SEDAR61-WP-06	An Index of Red Tide Mortality on red grouper in the Eastern Gulf of Mexico	David Chagaris and Dylan Sinnickson	17 August 2018
SEDAR61-WP-07	Updating indices of red tide severity for incorporation into stock assessments for the shallow-water grouper complex in the Gulf of Mexico	Skyler R. Sagarese, John F. Walter III, William J. Harford, Arnaud Grüss, Richard P. Stumpf, Mary C. Christman	17 August 2018
SEDAR61-WP-08	NMFS data summary for Gulf of Mexico red grouper maturity, sex transition and batch fecundity, 2014-2017	G. Fitzhugh, V. Beech, H. Lyon, P. Colson, L. Lombardi	17 August 2018
SEDAR61-WP-09	Summary of Red Grouper age-length data for SEDAR61	Linda Lombardi	21 August 2018
SEDAR61-WP-10	Index of abundance for Red Grouper ( <i>Epinephelus morio</i> ) from the Florida Fish and Wildlife Research Institute (FWRI) vertical longline survey in the eastern Gulf of Mexico	Heather M. Christiansen, Brent L. Winner, and Theodore S. Switzer	16 August 2018
SEDAR61-WP-11	Index of abundance for Red Grouper ( <i>Epinephelus morio</i> ) from the Florida Fish and Wildlife Research Institute (FWRI) repetitive time drop survey in the eastern Gulf of Mexico	Heather M. Christiansen, Brent L. Winner, and Theodore S. Switzer	16 August 2018
SEDAR61-WP-12	Red Grouper Abundance Indices from SEAMAP Groundfish Surveys in the Northern Gulf of Mexico	Adam G. Pollack, David S. Hanisko and G. Walter Ingram, Jr.	30 August 2018

SEDAR61-WP-13	A Summary of Red Grouper Size Distribution Data from Recreational Fishery Surveys in the Gulf of Mexico	Dominique Lazarre	11 Sept 2018
SEDAR61-WP-14	Potential red tide impacts on the annual spatial distribution of Red Grouper ( <i>Epinephelus morio</i> ) observed from fishery-independent video surveys	Kevin A. Thompson, Theodore S. Switzer, Sean F. Keenan <sup>1</sup> Christopher Gardner, Matt Campbell	13 November 2018
SEDAR61-WP-15	Proposed CPUE Expansion Estimation for Total Discards of Gulf of Mexico Red Grouper	Steven G. Smith, Allison C. Shideler, Kevin J. McCarthy	14 November 2018
SEDAR61-WP-16	Standardized Catch Rates of Red Grouper ( <i>Epinephelus morio</i> ) from the Gulf of Mexico Recreational Charterboat and Private Boat Fisheries (MRFSS) 1986-2017	Skyler Sagarese and Adyan Rios	21 November 2018
SEDAR61-WP-17	On aging procedures for multiple reef fish species	Ching-Ping Chih	16 November 2018
SEDAR61-WP-18	Apparent seasonal variations in age distributions and their linkage to aging procedures used for red snappers collected from the Gulf of Mexico	Ching-Ping Chih	16 November 2018 Updated: 6 Dec 2018
SEDAR61-WP-19	Model-estimated conversion factors for calibrating Coastal Household Telephone Survey (CHTS) charterboat catch and effort estimates with For Hire Survey (FHS) estimates in the Atlantic and Gulf of Mexico with application to red grouper and greater amberjack	Kyle Dettloff and Vivian Matter	21 February 2019
SEDAR61-WP-20	Timeline of severe red tide events on the West Florida Shelf: insights from oral histories	M. Karnauskas, M. McPherson, S. Sagarese, A. Rios, M. Jepson, A. Stoltz and S. Blake	21 June 2019
SEDAR61-WP-21	Commercial Landings of Red Grouper ( <i>Epinephalus morio</i> ) in the Gulf of Mexico	Beth M. Wrege and M. Refik Orhun	21 June 2019

<b>Final Stock Assessment Reports</b>		
SEDAR61-SAR1	Gulf of Mexico Red Grouper	SEDAR61 Panel

## 2. INPUT DATA

### 2.1 Stock Structure and Management Unit

The Red Grouper fishery has been managed as separate Gulf and Atlantic stock units with the boundary being U.S. Highway 1 in the Florida Keys (**Figure 2.1**). Given that no new information was presented related to the mixing of the Atlantic and Gulf of Mexico stock units, this assessment assumes that the Red Grouper fishery be managed as a separate stock within the Gulf of Mexico, until further studies may suggest otherwise.

### 2.2 Life History Parameters

Many of the life history parameters used in the assessment were identical to those adopted during SEDAR42, although some data inputs were updated using data through 2017. Reproductive parameters and age-growth parameters were re-examined at the SEDAR61 DW/AW Workshop due to the collection of additional data. A summary of the data presented, discussions and recommendations made during the Workshop are presented below.

#### 2.2.1 Conversion Factors

The meristic regressions were not updated for the SEDAR61 assessment and were identical to those recommended during SEDAR42 (SEDAR42 2015; Table 2.14).

#### 2.2.2 Age and Growth

A total of 48,287 Red Grouper were aged from otoliths collected from 1979 to 2017 (**Table 2.1**). The majority of samples (86.3%) were provided by the National Marine Fisheries Service (NMFS) Panama City Laboratory, followed by the Florida Fish and Wildlife Conservation Commission's Florida Fish and Wildlife Research Institute Fisheries Independent Monitoring (FWRI FIM; 11%), the Gulf States Marine Fisheries Commission Fisheries Information Network (GulfFIN; 2%), and the University of South Florida (USF; 0.8%). The gear type recorded most often was commercial longline (35.7%) followed by commercial vertical-line (25.4%), and the majority (56%) of age samples came from the Trip Interview Program (TIP). Commercial samples annually accounted for nearly 66% of otoliths aged followed by fishery-independent (22%) and recreational (12%). Nearly all age samples were obtained from Florida (99.6%), with a few obtained from Alabama (0.3%) and Louisiana (0.1%). Additional details are provided in SEDAR61-WP-09.

In order to measure indices of precision and reader bias, two reference sets were read by both the federal (NMFS Panama City) and the state (FWRI) ageing facilities. Good agreements were determined among readers for otoliths from both reference collections (NMFS PC: N = 204



whole otoliths,  $N = 36$  sections, Average Percent Error (APE) = 3.96%, Percent Agreement (PA) = 51%,  $PA \pm 1$  band = 78%; FWRI:  $N = 100$  sections, APE = 3.39%, PA = 70%,  $PA \pm 1$  band = 89%). As a measure of ageing error used in Stock Synthesis, standard deviations at age were calculated and resulted in similar values as provided in SEDAR42.

Growth was modeled using a single size-modified von Bertalanffy growth curve for both sexes combined which takes into account the non-random sampling due to minimum size restrictions (Diaz et al. 2004). The growth curve from SEDAR42 was updated using additional data collected (**Table 2.2**), which were primarily from fishery-independent surveys and increased sample sizes, particularly for the youngest age classes (**Table 2.3**). The updated von Bertalanffy parameters included  $L_{inf}$ , the asymptotic length,  $K$ , the von Bertalanffy growth coefficient, and  $t_0$ , the theoretical age at length zero, with recommended values of:

$$L_{inf}(\text{cm FL}) = 79.995$$

$$K (\text{year}^{-1}) = 0.1311$$

$$t_0 (\text{year}) = -0.8749 \text{ (adjusted to account for peak spawning on May 15}^{\text{th}})$$

The updated growth curve predicted slightly smaller sizes for older Red Grouper compared to the curve used in SEDAR42 (**Figure 2.2A**), whereas the growth trend was nearly identical for younger Red Grouper (**Figure 2.2B**).

The covariance structure for observed size-at-age differed for ages 0 to ages 2 (**Figure 2.3A**) and for lengths below 300 mm (**Figure 2.3B**). These age classes experienced the largest increase in sample size during SEDAR61 (**Table 2.3**). Following SEDAR42, the distribution of length-at-age was modeled using a coefficient of variation ( $CV$ ) that increased linearly with size ( $CV_{young} = 0.1423$  and  $CV_{old} = 0.1636$ ). This variance structure was recommended during the SEDAR42 Assessment Workshop (held via webinars) after reviewing internal analyses because it provides two  $CV$  estimates required for Stock Synthesis. Initially, the SEDAR42 Life History Working Group recommended using a constant  $CV$  at age ( $CV = 0.15$ ), which is supported by **Figure 2.3A** for most age classes. Exceptions are noted for the older age classes which showed reduced  $CV$ s, potentially due to much lower sample sizes (**Table 2.3**) limiting the ability to capture the true range of variability.

### 2.2.3 Natural Mortality

An age-specific vector of natural mortality ( $M$ ) was obtained using the Lorenzen (2005) estimator and a target  $M$  determined from the Hoenig (1983) teleost regression. Based on a maximum age of 29 years, the target  $M$  was  $0.14 \text{ yr}^{-1}$  and was used to calculate the age-specific vector of  $M$ . The age-specific vector of  $M$  was re-estimated using the resulting von Bertalanffy growth parameters for SEDAR61 (**Figure 2.2A**) and the first age at vulnerability into the fishery (age 5). The resulting age-specific  $M$  vector was compared to previous vectors, with the only difference being the predicted von Bertalanffy growth parameters used in the estimations (**Table 2.4**; **Figure 2.4**). Trends in age-specific  $M$  are nearly identical, with the exception of ages five and younger.

### 2.2.4 Discard Mortality

The post-Individual Fishing Quota (IFQ) discard mortality estimates for Red Grouper from the commercial longline and vertical line fisheries were updated using NMFS Observer data through 2017 (**Table 2.5**) following the approach recommended during SEDAR42. The estimate of 44.1% for the post-IFQ commercial longline, which was 0.5% higher than the estimate during SEDAR42, was derived as a weighted mean discard mortality rate based on the number of fishing sets in each depth bin. For the commercial vertical line, the estimate of 19.0% was unchanged from SEDAR42. This estimate was based on the recreational hook and line gear depth-dependent discard mortality function discussed in Sauls et al. (2014) for live Red Grouper discarded in fishing depths between 41 and 50 meters, where the vertical line fishery primarily operates (as identified in the commercial observer data). This recommendation is based on the assumption that vertical line gear is fished similar to recreational hook and line gear (in terms of retrieval and handling time). Additional details on the Observer Program are provided in Pulver et al. (2014). The discard mortality for the commercial trap fishery was set at 10% following past assessments (**Table 2.6**).

The discard mortality for the recreational discards remained at 11.6% as in SEDAR42. This estimate reflects the mean overall depth-integrated estimate in Sauls et al. (2014) and includes all sources of latent discard mortality for fish that were able to re-submerge and those that were alive and floating after release.

## **2.2.5 Reproduction**

### **2.2.5.1 Maturity**

New maturity information was provided by NMFS Panama City (916 records; SEDAR61-WP-08) and FWRI (1,080 records; SEDAR61-WP-04) for years 2014 through 2017 for SEDAR61. Female reproductive phase by month was consistent with previous observations of spawning seasonality during SEDAR42, with actively spawning females primarily observed between March and June. Spawning capable females collected throughout the year support asynchronous spawning behavior, as observed in Lowerre-Barbieri et al. (2014).

During the SEDAR61 DW/AW Workshop, age and size at maturity were re-estimated using the same data filtering recommendations made during SEDAR42 and logistic regression analysis based upon weighted sums of binary data. The inclusion of the 2014-2017 data led to a slightly younger age-at-maturity of 2.2 years (SEDAR42, 2.8 years), which was largely driven by the addition of younger fish collected in fishery-independent surveys (SEDAR61-WP-04). Ultimately, the estimates recommended during SEDAR42 were retained due to minor differences following the addition of new data (**Table 2.7; Figures 2.5-2.6**) and minimal impact on the fecundity-at-age vector.

### **2.2.5.2 Sexual Transition**

New sexual transition information was provided by NMFS Panama City (916 records; SEDAR61-WP-08) and FWRI (1,080 records; SEDAR61-WP-04) for years 2014 and 2017 for SEDAR61. As observed previously, there is broad overlap of the size and age range of male and

female Red Grouper. From the new data, 17 Red Grouper were deemed transitional and ranged from 2 to 14 years in the FWRI dataset (SEDAR61-WP-04) and 6 to 7 years in the NMFS Panama City dataset (SEDAR61-WP-08). Both sources reported old females, with NMFS Panama City reporting Red Grouper up to age 19 and FWRI reporting Red Grouper up to age 20. The occurrence of females at older ages and larger sizes may be biologically relevant, although additional research is needed to enhance our understanding of the Red Grouper harem mating system.

During the SEDAR61 DW/AW Workshop, age and size at sexual transition were re-estimated using the same data filtering recommendations made during SEDAR42 and logistic regression analysis based upon weighted sums of binary data. Since the updated estimate was nearly identical (11.4 vs 11.2 years; 707 vs 708 mm FL) (**Table 2.7; Figures 2.7-2.8**), the estimate recommended during SEDAR42 was retained for continuity.

### 2.2.5.3 Fecundity

Prior to SEDAR42, gonad weight (of ovaries with vitellogenic and maturing oocytes) was used as the form of reproductive potential. Due to large variation in gonad weight discussed during SEDAR42, the SEDAR42 Life History Working Group recommended the power function fit of the batch fecundity data as the form of female reproductive potential. This approach was followed during SEDAR61.

New batch fecundity (number of eggs) information was provided by NMFS Panama City (10 records; SEDAR61-WP-04) for years 2014 and 2017 for SEDAR61. During the SEDAR61 DW/AW Workshop, batch fecundity by age and length were re-estimated using non-linear regression. The addition of new data resulted in some change in fit by age (**Figure 2.9**) but no change by length (**Figure 2.10**). The sensitivity of the relationship by age was discussed in detail at the SEDAR61 DW/AW Workshop. The SEDAR61 DW/AW Panel recommended use of batch fecundity as a function of length and to convert it to age using the growth curve (**Figure 2.11**). The relationship of fecundity-at-length was considered a better biological determinant given the sensitivity of the fecundity-at-age to a few older individuals.

The decision by the SEDAR61 DW/AW Panel to maintain fecundity-at-age (i.e., via converting fecundity-at-length to fecundity-at-age) in the assessment model was based on maintaining the approach used in SEDAR42. During SEDAR42, a combined single sex SS model was developed that treats males and females identically. To account for a decrease in population total fecundity as females transition and become males, total fecundity at age (relative number of eggs) was modeled as:

$$Fecundity_{age} = Proportion\ female_{age} \times Proportion\ Mature_{age} \times Batch\ Fecundity_{age}$$

Note that this relationship does not take into account spawning frequency nor the number of batches. The fecundity-at-age vector was fixed within the assessment model and spawning stock biomass (SSB) was defined as the number of eggs in the assessment model (relative number rather than an absolute number) (**Figure 2.12**).

## 2.3 Commercial Fishery Data

The primary commercial gears used for Gulf of Mexico Red Grouper are vertical hook and line (hook and line, electric/hydraulic bandit reels, trolling, etc.), longline, and trap (prior to 2007). The data collected from these fisheries include landings, size and age composition of landings, discards, size composition of discards, and catch-per-unit-effort (CPUE). All of these data streams except the commercial CPUE indices were updated through 2017.

### 2.3.1 Landings

Commercial landings of Red Grouper for the U.S. Gulf of Mexico were constructed primarily using data housed in the NOAA's Southeast Fisheries Science Center's Accumulated Landings System from 1963 through 2017. As in SEDAR42, Florida landings from 1986 through 2013 were obtained from the Florida Trip Ticket program. Landings from the Individual Fishing Quota (IFQ) program were used for 2010-2017. Final landings were then provided by year and gear (**Table 2.8**). Additional details on methodology and assumptions are provided in SEDAR42 and SEDAR61-WP-21. For SEDAR61, the commercial landings estimated for the vertical line, longline, trap and other gears have not changed substantially from the estimates provided for SEDAR42 (**Figure 2.13**). Landings by vertical line, longline and trap fleets were used in the assessment model, and recent declines are evident for all gear types. As in SEDAR42, landings reported under 'other' were excluded as they made up less than 1% of overall commercial landings. The percentage of commercial quota reached has declined substantially over the last four years (**Figure 2.14**).

### 2.3.2 Size and Age Composition of Landings

All length and age data from commercial landings were updated through 2017. Commercial samples were grouped into three strata: vertical line, longline and trap (**Table 2.9**). Length samples from commercial fisheries were obtained from the TIP database housed at the Southeast Fisheries Science Center (SEFSC). Otolith samples were subsamples of length samples (**Table 2.10**). Age samples were processed and read by NMFS Panama City.

Length and age frequency distributions for each commercial fleet were determined following the procedures used in SEDAR42 (see Chih 2014). Length frequency distributions for the vertical line and longline fleets were estimated separately for the northern (NMFS Shrimp Statistical Zones 6 – 11; **Figure 2.1**) and southern (NMFS Shrimp Statistical Zones 1 – 5; **Figure 2.1**) Gulf of Mexico. The separation around 28°N latitude was based on previous research suggesting regional differences in size and age of Red Grouper, with older and larger Red Grouper more common in the southern Gulf region (Lombardi-Carlson et al. 2008; Chih 2014). This stratification approach was followed for vertical line and longline samples collected since 2000 because of sufficient sample sizes in each region. For the estimation of length frequency distributions prior to 2000, as well as samples collected from the trap fishery, no stratification was done due to relatively smaller sample sizes by region (**Table 2.9**).

Age frequency distributions were obtained for each fleet using the previously published (Chih 2009) reweighting approach that was used during SEDAR42. For each fleet, age samples were

reweighted by length samples to account for concerns regarding the representativeness of the age samples due to suspected non-random sampling of some otolith samples. For the vertical line and longline fisheries, samples collected during and after 2000 were grouped into northern and southern Gulf regions and reweighted by the length frequency distributions for each region. The resulting region-specific age frequency distributions were then combined and weighted by the landings of the two regions. For the estimation of age frequency distributions prior to 2000, as well as samples collected from the trap fishery, no stratification was done due to relatively smaller sample sizes by region (**Table 2.10**).

Reweighted age frequency distributions for Red Grouper landed by the commercial vertical line fishery are shown in **Table 2.11**. Strong cohorts starting around age 5 were noted in 2004 and 2011. No large deviations in age composition were evident from the age composition used in SEDAR42, although minor differences (up to 8.1%) were noted in early years where sample sizes were low (**Table 2.12**).

Reweighted age frequency distributions for Red Grouper landed by the commercial longline fishery are shown in **Table 2.13**. Strong cohorts starting around age 6 are evident in 2005 and 2012. With the exception of 1997, no large deviations (< 6%) in age composition were evident from the age composition used in SEDAR42 (**Table 2.14**). Only seven Red Grouper were aged in 1997, and as a result this year was excluded from the assessment.

Reweighted age frequency distributions for Red Grouper landed by the commercial trap fishery are shown in **Table 2.15**. Strong cohorts are not as evident in the trap composition. With the exception of a few earlier years, no large deviations (< 5%) in age composition were evident from the age composition used in SEDAR42 (**Table 2.16**). The age compositions for 1992 and 1994 varied due to corrections in assigned annual ages of one fish in 1992 and six fish in 1994.

### **2.3.3 Discards**

Commercial discards are available by gear for trap, vertical line, and longline. Numbers of discards for the commercial trap fishery were retained from SEDAR42 (SEDAR42 2015), the SEDAR12 2006 benchmark (SEDAR12 2006) and the 2009 update assessment (SEDAR12 Update 2009) since fish traps were banned in the Gulf of Mexico beginning in 2006.

During the SEDAR42 Data Workshop, commercial Red Grouper discards for vertical line and longline were calculated using discard rates as reported by fisheries observers, with the discard rates multiplied by year-specific total effort reported to the coastal logbook program to estimate total discards. However, additional analyses were conducted post-SEDAR42 Data Workshop due to concerns over the reliability of the logbook effort data, and as a result commercial discards were re-estimated based on observed discard and kept rates from the NMFS Observer Program database. Even with the modifications during SEDAR42, estimated commercial discards received considerable attention as they were substantially higher than previous assessments, but were maintained at the time due to anecdotal information supporting high discard fractions.

### SEDAR61 recommended methods

Since SEDAR42, additional research was undertaken to investigate the methodology for calculating commercial discards, specifically by exploring available effort units (e.g., trip-days, hook-hours, etc.) for estimating commercial discards. The general approach for estimating discards for the commercial reef-fish fleet in the Gulf of Mexico utilizes CPUE from the coastal observer program and total fishing effort from the commercial reef logbook program to estimate total catch. CPUE was determined from the coastal observer program in which scientific observers on commercial fishing vessels recorded detailed information on catch and effort for a subset of trips. The coastal observer program began in July 2006; for discard estimation, complete calendar years 2007-2017 were utilized.

Total effort was determined from the commercial reef logbook program in which fishers reported basic information on effort and catch by species for every trip. The reef logbook program began in 1990 for a subset of vessels in the Gulf of Mexico, and expanded to all vessels in 1993; for discard estimation, complete calendar years 1993-2017 were utilized. Logbook effort metrics were recorded at the trip level, whereas observer effort metrics were recorded at a finer scale (usually individual ‘sets’ within a trip). A suite of effort metrics recorded on commercial logbooks and collected by onboard observers were evaluated to identify unbiased and consistent effort variables between the two programs for carrying out the catch expansion. Additional details are provided in SEDAR61-WP-15.

For the commercial vertical line, three effort units were explored: (i) the number of lines per set, (ii) the number of hooks per line, and (iii) the total hours fished (**Table 2.17**). Due to potential ambiguous interpretation of these metrics by fishers, a variety of metrics were analyzed (e.g., average lines per set for a trip, maximum lines fished for a set during a trip, etc.). The trip fishing time (“fishing day”) was found to be unbiased and selected as the most appropriate effort variable for logbook and observer data (**Figure 2.15; Table 2.17**), and was computed as the cumulative daily fishing time from first hook in to last hook out (including active fishing and transit time). Using this effort unit, CPUE expansion estimates of annual total landed catch compared favorably with reported logbook landings for both the observer program time frame (2007-2017) and the hindcast time frame (1993-2006) (**Figure 2.16**).

For the commercial longline, three effort units were explored: (i) the number of sets per trip, (ii) the average hooks per set, and (iii) the average soak-time per set (**Table 2.18**). Soak-time was calculated using various combinations of first hook in, last hook in, first hook out, and last hook out due to discrepancies in the definition of soak-time for the observer and logbook programs. The number of sets per trip was found to be unbiased and selected as the most appropriate effort variable for logbook and observer data (**Figure 2.17; Table 2.18**). Using this effort unit, CPUE expansion estimates of annual total landed catch compared favorably with reported logbook landings for both the observer program time frame (2007-2017) and the hindcast time frame (1993-2006) (**Figure 2.18**).

Commercial discards in numbers of Red Grouper are summarized in **Table 2.19**. A comparison of the discards calculated using the recommended method to the values used in SEDAR42 are provided in **Figure 2.19**.

#### **2.3.4 Size Composition of Discards**

The Reef Fish Observer Program provides detailed information for each trip and each fish captured, including the size and disposition of Red Grouper caught. Length composition data of discarded fish from the commercial fishery were available and included in the model for the vertical line and longline fleets for 2006-2017.

Length composition data of discarded fish from the commercial vertical line fishery are shown in **Table 2.20**. No large deviations in size composition were evident from the size composition used in SEDAR42 (**Table 2.21**). Length composition data of discarded fish from the commercial longline fishery are shown in **Table 2.22**. No large deviations in size composition were evident from the size composition used in SEDAR42 (**Table 2.23**).

### **2.3.5 Catch-per-unit-effort (CPUE)**

All commercial CPUE indices used in the SEDAR61 assessment are summarized in **Table 2.24**.

Data from the NMFS Coastal Logbook Program were used during SEDAR42 to construct standardized CPUE indices of abundance for the populations of Red Grouper in the eastern Gulf of Mexico (NMFS Shrimp Statistical Zones 1-11; **Figure 2.1**). The indices included the years 1993 through 2009 prior to the implementation of the Individual Fishing Quota (IFQs), because prior to 1993 only 20% of Florida vessels were sampled. During SEDAR42, post-IFQ indices were considered but not recommended for inclusion into the assessment because the implementation of the IFQ system is believed to have changed fishing behavior and catchability compared to the earlier years. Accordingly, the commercial CPUE indices were not updated for this assessment. Due to the difficulty in obtaining CPUE indices that accurately reflect resource abundance, particularly for fisheries with highly complex regulations that may impact the relationship between catch rates and abundance, a sensitivity run was carried out with no CPUE indices incorporated (i.e., satisfying TOR 2b). While there is a need to incorporate post-IFQ years into the overall time series in the most appropriate manner, additional research is needed to better understand the influence of the IFQ program on fisher behavior and investigate alternative analyses.

## **2.4 Recreational Fishery Data**

The primary recreational modes of fishing for Gulf of Mexico Red Grouper are private, charter, and headboat. Estimates of the catch of Red Grouper come from a combination of results from two surveys: (1) the Marine Recreational Information Program (MRIP), formerly the Marine Recreational Fisheries Statistics Survey (MRFSS), conducted by NMFS; and (2) the Southeast Region Headboat Survey (SRHS) conducted by NMFS, Southeast Fisheries Science Center Beaufort Laboratory in North Carolina. The MRIP survey is sampling-based, whereas the SRHS is a census of headboats using logbooks. The two surveys together provide estimates of catch in numbers, estimates of effort, length and weight samples, and catch-effort observations for shore-based and boat fishing. In addition to length and age samples provided by MRIP and SRHS, samples were also obtained from the Gulf Fisheries Information Network (GulfFIN), Trip Interview Program (TIP), and Florida Fish and Wildlife Conservation Commission Fish and Wildlife Research Institute (FWRI) At-Sea Observer programs. Landings of Red Grouper are

sparse in the Texas Parks and Wildlife Department (TPWD) Survey (22 in 2007; 11 in 2008) and the Louisiana Creel Survey (118 in 2014; 29 in 2016; 12 in 2018).

### MRIP transition

The Marine Recreational Information Program completed a three year transition in 2018 (NOAA Fisheries 2018). Estimates of fishing effort for the private and shore modes are now obtained from a Fishing Effort Survey conducted via mail, which uses angler license and registration information to identify and contact anglers as well as supplemental data from the U.S. Postal Service that includes nearly all U.S. households. Effort estimates for charter and party boats are still obtained from the For-Hire Telephone Survey and are not affected by the new Fishing Effort Survey. Previously, estimates of private and shore fishing effort came from the legacy Coastal Household Telephone Survey, which used random-digit dialing of homes in coastal counties to contact anglers. Concerns over low response rates, the gatekeeper effect (i.e., speaking to someone other than the angler), the tendency to ignore unknown callers, and coverage limited to only coastal counties in the Coastal Household Telephone Survey were motivation for the new survey, which is considered to provide more accurate estimates of trips. By design, the Fishing Effort Survey is reaching more anglers, getting into the right hands, providing a higher response rate, and extracting more information from anglers with an improved survey questionnaire. Benchmarking of the Fishing Effort Survey alongside the Coastal Household Telephone Survey for three years allowed for apples-to-apples comparisons between data from the two different surveys and the creation of a peer-reviewed calibration model. The calibration model was peer reviewed by reviewers appointed by the Center for Independent Experts (see Rago et al. (2017)). Additional details can be found at: <https://www.fisheries.noaa.gov/event/fishing-effort-survey-calibration-model-peer-review>.

The MRIP transition also accounted for the 2013 design change in the Access Point Angler Intercept Survey (Foster et al. 2018). Improved survey procedures were incorporated that better account for all types of completed trips and remove potential sources of bias from the survey design. For example, the new sampling design provides more complete coverage of angler fishing trips ending throughout the day and night, whereas the old design often missed nighttime trips or off-peak daytime trips. In addition, conversion factors were developed to account for any consistent effects of the redesign on catch rate estimates produced by the Access Point Angler Intercept Survey. The new Access Point Angler Intercept Survey design uses a sample weight adjustment method and is more statistically sound because it more strictly adheres to formal probability sampling protocols. The Access Point Angler Intercept Survey calibration model developed by MRIP and the statistical approach proposed for the conversion of catch estimates by MRIP were peer reviewed by reviewers appointed by the Center for Independent Experts. Additional details can be found at: <https://www.fisheries.noaa.gov/event/access-point-angler-intercept-survey-calibration-workshop>.

The MRIP transition results in nearly three times higher effort for the private mode (**Figure 2.20**), largely due to significant drivers including the telephone versus mail factor in the early period and the wireless effect in more recent years. The proportional change becomes increasingly greater between 2001 and 2017 due to the “wireless effect”, which has significantly



decreased the coverage of the Coastal Household Telephone Survey since cellphones replaced many landlines.

### Charter calibration

The MRIP transition resulted in the release of new recreational catch estimates for all species and all modes, including charter mode estimates. As a result, the SEFSC conducted a calibration analysis using the newly released data to correct for this change from the Coastal Household Telephone Survey to the For-Hire Telephone Survey (SEDAR61-WP-19). The analysis uses a statistically sound, consistent methodology to provide improved calibrations for estimating For-Hire Telephone Survey charterboat effort and landings with associated uncertainties from Coastal Household Telephone Survey estimates. Additional details are provided in SEDAR61-WP-19.

### **2.4.1 Landings**

Recreational landings in numbers of Red Grouper by the headboat, charter, and private modes were aggregated into a single recreational fleet and used in the SEDAR61 assessment model. This decision follows the SEDAR42 Review Panel recommendation for a single recreational fleet because the headboat fleet represented a very small percentage of overall Red Grouper landings (<5%). Recreational landings derived from MRIP were comprised of Red Grouper landed whole and observed by interviewers ("Type A") and Red Grouper reported as killed by the fishers ("Type B1"). Landings from the shore mode were excluded since they were a minor component of overall recreational landings (1.6%). Monroe County estimates were excluded from the Gulf of Mexico stock because they were attributed to the South Atlantic stock (SEDAR19 2010). During SEDAR19 for South Atlantic Red Grouper, analyses conducted on a subset of data between 2005 and 2008 suggested ~91% of Red Grouper landed in the Keys were taken on trips fishing in Atlantic waters off the Keys (SEDAR19 2010).

Recreational landings by fishing mode (charter, headboat, and private) are summarized and compared to estimates from SEDAR42 in **Table 2.25**. Recreational landings differ considerably from those estimated for SEDAR42 (**Figure 2.21**) due to the changes in MRIP discussed above. Private landings estimated for SEDAR61 are consistently higher across years, and range from 1.2 to 5 times higher than SEDAR42 landings estimates. While headboat landings are identical after 1986 (via the SRHS), SEDAR61 estimates between 1981 and 1985 from MRIP are 2.3 to 8.2 times higher than the SEDAR42 estimates. While charter landings estimated for SEDAR61 are larger than SEDAR42 in earlier years (range 1.2 to 7.3 times higher), the latter portion of the time series shows lower or equivalent SEDAR61 landings. Large changes in the magnitude of landings by mode are evident (see y-axes in left panels, **Figure 2.22**). The proportions of landings by mode also show some differences, although the trend is consistent in that the majority of Red Grouper are caught by private anglers followed by charter (**Figure 2.22**). Overall, the percentage of landings by mode are generally similar to those in SEDAR42: private (81.6% vs 76.8%), charter (12.3% vs 17.2%), headboat (4.5% vs 4.8%), and shore (1.6% vs 1.2%).

### **2.4.2 Size and Age Composition of Landings**

Recreational length samples were obtained from multiple data sources including GulfFIN, MRIP, SRHS, and TIP (**Table 2.26**). The majority of length samples were provided by MRIP for the charter (82.8%) and private (90.9%) modes, whereas 94.2% of headboat length observations were obtained from the SRHS (**Table 2.27**).

#### MRIP size data post-MRIP transition

The MRIP transition also resulted in changes to the size data collected during trip interviews. The new MRIP size files account for both the Access Point Angler Intercept Survey design change in 2013, as well as the transition from the Coastal Household Telephone Survey to the Fishing Effort Survey in 2018. In addition to providing fish level length and weight data and variables required for use in estimation, two major changes to the size data have occurred: (1) missing lengths and/or weights are now imputed as needed for individual fish records; and (2) post-stratified sampling weights are now available for use in weighted estimation for the size dataset.

Prior to the MRIP transition, MRIP size data only included observed lengths. Missing lengths are now imputed or filled in by species at the individual angler-trip level using either length-weight modeling ( $W = a \times L^b$ ) or a mix of hot and cold deck imputation. To fill in missing details or observed lengths, hot deck imputation stays within similar cells for as long as possible and collapses cells using standard estimation domains (e.g., wave, state, year, etc.).

The MRIP transition also resulted in the calculation of sample weights following standard design-based probability sampling theory to produce unbiased estimates. The “wp\_size” variable available in the dataset is the post-stratified sampling weight for use in weighted estimation for the size dataset only. It contains an additional adjustment for situations when only a subset of landed fish are measured for an angler-trip.

#### SEDAR61 recommended use of MRIP size data for Red Grouper

Some caveats were discussed in detail regarding the MRIP imputation process as it pertains to Red Grouper. The MRIP imputation process included Monroe County in the Gulf and did not account for regional differences within states, such as the observed difference in size of Red Grouper between the northern and southern West Florida Shelf (discussed in **Section 2.3.2**). In addition, the number of imputed lengths can exceed the number of observed lengths, which can lead to more weighting for imputed records than for observed records for many years (**Table 2.28**). To explore these caveats for Red Grouper, we investigated differences in length composition using cumulative distribution functions between:

1. observed only MRIP lengths and imputed only MRIP lengths; and
2. MRIP combined length data (observed and imputed) using sample weights and not using sample weights.

With the exception of the first few years where sample sizes were generally low, no appreciable differences in distribution were evident in annual length compositions between observed only MRIP lengths and imputed only MRIP lengths (**Figure 2.23**) or between unweighted MRIP

length composition and weighted MRIP length composition when using all available length data (**Figure 2.24**). As a result, the SEDAR61 DW/AW Panelists recommended the use of the complete MRIP size dataset (imputed and observed lengths) and the consideration of sample weighting for estimation of length frequency distributions of Red Grouper, which follows the general recommendation from the NMFS Office of Science and Technology. The NMFS Office of Science and Technology recommendations were based on the intent of imputing values from similar trips, which is to reduce the potential for any bias that might arise when missingness is not completely at random. As an example, if inshore trips have a higher rate of missingness than offshore trips, then using only the observed values could lead to a bias if there are differences in lengths among these groups. Imputation is a commonly applied standard practice in survey methodology for addressing missingness.

#### SEDAR61 recommended combination of Red Grouper size data for length frequencies

The remaining recreational datasets including SRHS, TIP, and GulfFIN only collect observed records and do not include sample weights, thereby complicating the combining of these datasets with the recommended MRIP size dataset (**Table 2.29**). Specifically for developing charter/private length composition for Red Grouper, the SEDAR61 DW/AW Panel recommended using MRIP length data only (observed + imputed, with sample weights) given the preponderance of length samples for charter (82.8%) and private (90.9%) (**Table 2.30**). For the headboat length composition, all length data were used, with 94% of samples collected during the SRHS (**Tables 2.30**).

#### SEDAR61 continuity size composition

Length frequency distributions were determined following the procedures used in SEDAR42 for the aggregate recreational fleet (private, charter, headboat). No north versus south stratification was done due to relatively smaller sample sizes by region. For the continuity, only observed lengths were considered in analyses. Once length frequency distributions were obtained, they were used to develop age compositions for the recreational fleet (discussed below).

#### SEDAR61 recommended size composition

Length frequency distributions were determined for the charter/private and headboat modes separately using the recommended length data (**Table 2.30**). Once length frequency distributions were obtained for each, they were used to develop age compositions for the recreational fleet (discussed below).

#### Age composition of landings

The majority of age samples were obtained from the charter mode, followed by the headboat and private modes (**Table 2.31**).

#### Continuity age composition

Age frequency distributions were obtained for the recreational fleet using the previously published (Chih 2009) reweighting approach that was used during SEDAR42. For the recreational fleet, age samples were reweighted by length samples to account for concerns regarding the representativeness of the age samples due to suspected non-random sampling of some otolith samples. As discussed above, length data were treated exactly as in SEDAR42 for the continuity. Specifically, all recreational length data were combined and a single length composition was developed using observed lengths (i.e., no imputed lengths) for all available data sources. Sampling weights were not considered for the MRIP size data in the continuity. The age composition for the continuity was then determined using all age data lumped together and reweighted by the recreational combined length composition. As in SEDAR42, no stratification by region (i.e., north vs south West Florida Shelf) or mode was considered.

Age composition data of landed fish from the recreational fishery using the continuity approach are shown in **Table 2.32**. Strong cohorts are evident starting around age 4 in 2003 and 2010. Overall, deviations in age composition were minor (up to 9%) when compared to the age composition used in SEDAR42 (**Table 2.33**).

#### SEDAR61 recommended approach to develop recreational age composition

While the same general approach to developing age composition was recommended for SEDAR61, i.e., reweighting approach discussed above, changes to the treatment of the length and age data were recommended based on the MRIP transition and the analyses discussed in the previous sub-sections. Length compositions were first developed separately for the charter/private modes combined (using MRIP observed and imputed lengths observations and the sample weights) and the headboat mode (using all observed lengths). Age compositions were then determined for the charter/private and the headboat modes separately using the reweighting approach discussed above. Lastly, a single age composition for the combined recreational fleet was determined by weighting the charter/private age composition and the headboat age composition by their respective landings.

Age composition data of landed fish from the recreational fishery using the recommended approach are shown in **Table 2.34**, and also reveal strong cohorts in 2003 and 2010. Deviations in age composition were larger than observed in the continuity due to the consideration of landings when weighting the age compositions by mode. More weight was given to charter/private than the headboat. This is particularly evident in 1991 where charter/private had a sample size of 1 which leads to an unrealistic peak at age 20+ (**Table 2.35**), which is not representative of the fishery and was excluded from the assessment. For years with more data, the differences are much smaller.

#### **2.4.3 Discards**

Recreational discards in numbers of Red Grouper by the headboat, charter, and private modes were used in the assessment model. MRIP/MRFSS estimates of live released fish (B2) for charter, private, and headboat (1981-1985 only) were adjusted in the same manner as landings (i.e., discussed above) and did not include Monroe County. Self-reported discards have been reported in the SRHS logbook since 2004 and were validated using the Headboat At-Sea

Observer program during SEDAR42. As a result, headboat discards from 2007 to present were derived directly from the SRHS. SEDAR42 recommended the MRFSS/MRIP Charter:SRHS discard ratio be used as a proxy to estimate Red Grouper discards from headboats for years prior to 2007 in Florida (discards in other Gulf states assumed negligible).

Recreational discards by fishing mode (charter, headboat, private) are summarized and compared to estimates from SEDAR42 in **Table 2.36**. Recreational discards differ considerably from those estimated for SEDAR42 (**Figure 2.25**) due to the changes in MRIP discussed above. Private discards are consistently higher across years and range from 1.8 to 5 times higher than discard estimates provided during SEDAR42. In contrast, charter and headboat discards are generally similar to estimates from SEDAR42, with the exception of the early years where SEDAR61 values are much larger (1.4 to 4.3 times higher). Large changes in the magnitude of discards by mode are evident (see y-axes in left panels, **Figure 2.26**). While the proportions of discards by the private mode are more dominant in the SEDAR61 estimates across years, the trend in discards remains similar, with the majority of Red Grouper discarded by private anglers followed by charterboats (**Figure 2.26**). Overall, the percentages of discards by mode are generally similar to those in SEDAR42: private (90.1% vs 76.4%), charter (6.6% vs 14.9%), headboat (2.6% vs 4.9%), and shore (0.7% vs 3.9%).

#### **2.4.4 Size Composition of Discards**

The FWRI At-Sea Observer Program provides valuable information on the size distribution and condition of discarded fish. Funding for the survey has been variable over the time period, and therefore regional sampling has not always been consistent. Between 2005 and 2007, At-Sea Observer Surveys were conducted for headboats from the panhandle of Florida through the Keys. In June 2009, the state of Florida secured an alternative funding source to cover at-sea observers on both headboats and charter vessels from the panhandle to central Florida. Data from 2014 were excluded from analyses because they were collected with a special permit. Additional details on sampling protocols are provided in SEDAR61-WP-13.

Length composition data of discarded Red Grouper from the recreational fishery were available and included in the model for 2005-2007, 2009-2013, and 2015-2017 (**Table 2.37**). Following SEDAR42, length composition was first determined separately for headboat (weighted based on different trip-types; see SEDAR61-WP-13) and charter and then combined into a single length composition based on relative sample sizes. Length composition data of discarded fish from the recreational fishery are shown in **Table 2.38**, with fish below the size limit primarily discarded (20 inches Total Length, or 48.8 cm Fork Length). For most years, the deviations in size composition were small when compared to the size composition used in SEDAR42 (**Table 2.39**). The minor differences (up to 16%) in 2010 through 2013 were due to an error when pasting in the final composition data used in SEDAR42. The largest difference in length composition becomes 5% between SEDAR61 and SEDAR42 after correcting the SEDAR42 length composition.

#### **2.4.5 Catch-per-unit-effort (CPUE)**

##### MRIP/MRFSS index of abundance

MRIP/MRFSS has monitored shore based, charterboat and private/rental boat angler fishing in the Gulf of Mexico since 1981. Publically available MRIP data collected on catch and trip information were used to construct an index of Red Grouper catch rates in the Gulf of Mexico. Data filtering and trip selection via Stephens and MacCall (2004) were identical to the procedure followed during SEDAR42. The index was constructed using a delta-lognormal approach and Generalized Linear Mixed Models. CPUE was calculated on an individual trip basis and was equal to the number of fish caught (landed + discarded) divided by the total effort, where effort was the product of the number of anglers and the total hours fished. Additional details are provided in SEDAR61-WP-16.

Following SEDAR42, the index developed from the MRIP survey using standard delta-lognormal methods was included in the SEDAR61 assessment model. All SEDAR61 index values fell within the confidence interval for the SEDAR42 index (**Figure 2.27A**). With the exception of the first few years of the index, the trend was generally similar between the SEDAR42 and SEDAR61 indices (**Figure 2.27B**). Relative abundance derived from MRIP has decreased in recent years, although a slight increase occurred from 2016 to 2017 (**Table 2.40**). The difference in relative abundance for the first few years is due to minor differences in trip selection.

### Headboat

The SRHS has monitored catch and effort from party (head) boats in the Gulf of Mexico since 1986. SRHS data were used to construct an index of Red Grouper catch rates in the Gulf of Mexico following the same data preparation and filtering techniques as SEDAR42 (see Rios 2015). CPUE was calculated on an individual trip basis as the number of Red Grouper landed divided by the effort, where effort was the product of the number of anglers and the total hours fished. The index was constructed using Generalized Linear Mixed Models and a delta-lognormal approach (Lo et al. 1992). Additional details are available in SEDAR61-WP-05.

Following SEDAR42, the index developed from the headboat survey using standard delta-lognormal methods was included in the SEDAR61 assessment model. All SEDAR61 index values fell within the confidence interval for the SEDAR42 index (**Figure 2.28A**). The trend was nearly identical between the SEDAR42 and SEDAR61 indices, although very minor differences were noted (**Figure 2.28B**). Recent declines in relative abundance are evident, with the lowest abundance documented in 2017 (**Table 2.40**). As observed during SEDAR42, the Headboat index continues to be associated with high variability compared to other indices (**Tables 2.24 and 2.41**).

## **2.5 Fishery-Independent Surveys**

There are four main sources of fishery-independent data used in this assessment. Three were used in the SEDAR42 assessment including: (1) the Southeast Area Monitoring and Assessment Program (SEAMAP) Summer Groundfish Survey; (2) the NMFS Bottom Longline Survey; and (3) the Combined Video Survey. SEAMAP is a collaborative effort between federal, state and university programs that is designed to collect, manage and distribute fishery-independent data

throughout the region. During SEDAR42, the SEAMAP Summer Groundfish Survey was recommended for use because it captures the smallest Red Grouper and serves as a recruitment index. The NMFS Bottom Longline Survey was recommended for use because it covers the entire depth range of Red Grouper and has good spatial and temporal coverage. The Combined Video Survey, a collaboration between the SEAMAP Reef Fish Video Survey conducted by NMFS Mississippi Laboratories, NMFS Panama City, and Florida Fish and Wildlife Conservation Commission's Fish and Wildlife Research Institute (FWRI), was recommended for use by the SEDAR42 Index Working Group to improve spatial coverage. For the SEAMAP Summer Groundfish and NMFS Bottom Longline Surveys, the methodologies used to standardize and incorporate these data into the assessment are identical to those employed during SEDAR42 and therefore are only briefly reviewed below. Due to considerable improvements in methodology since SEDAR42, a more detailed review of the analytical methods for the Combined Video Survey is provided.

For SEDAR61, a new fishery-independent data source was incorporated into the assessment. The FWRI Hook and Line Repetitive Time Drop Survey was recommended for use because of its coverage of critical Red Grouper habitat and associated size composition. The size composition in particular was considered of great value for the current assessment given concerns over the recent decline in Red Grouper abundance throughout the region.

All fishery-independent indices that were used in the SEDAR61 assessment are summarized in **Table 2.41**. The indices that were selected for use included:

SEAMAP Summer Groundfish Survey: 2009-2017  
NMFS Bottom Longline Survey: 2001 & 2003-2017  
Combined Video Survey: 1993-1997, 2002 & 2004-2017  
FWRI Hook and Line Repetitive Time Drop Survey: 2014-2017

Although the FWRI Vertical Line Survey was considered, it was not used in the SEDAR61 Base Model due to overlap with the FWRI Hook and Line Repetitive Time Drop Survey and limited length composition. Additional details can be found in SEDAR61-WP-10.

### ***2.5.1 SEAMAP Summer Groundfish Survey***

Standardized trawl surveys have been conducted in the Gulf of Mexico (GOM) since 1972 and continued under the SEAMAP in 1982 and 1987 for the summer and fall, respectively. The primary objective of this trawl survey conducted semi-annually is to collect data on the abundance and distribution of demersal organisms in the northern GOM. Prior to 2009, the summer survey did not sample from Mobile Bay, Alabama eastward to Florida and therefore missed prime Red Grouper habitat. Full survey details can be found in Nichols (2004). The other changes to the survey are outlined in SEDAR61-WP-12 and in Pollack and Ingram (2010).

Following SEDAR42, the index developed from the SEAMAP Summer Groundfish Survey using standard delta-lognormal methods was included in the SEDAR61 assessment model. Based on the distribution of Red Grouper in trawls and the lack of consistent spatial coverage by the fall trawl survey, indices of Red Grouper abundance were developed utilizing only stations

within NMFS Shrimp Statistical Zones 2 – 8 (**Figure 2.1**) from 2009 to 2017 using summer trawl data (SEDAR61-WP-12; **Figure 2.29**). All SEDAR61 index values fell within the confidence interval for the SEDAR42 index (**Figure 2.29A**). The trend was similar between the SEDAR42 and SEDAR61 indices, although slight differences in magnitude were noted (**Figure 2.29B**). Although relative abundance has declined since 2009, it has remained relatively stable in the last few years, with the lowest abundance documented in 2017 (**Table 2.41**).

Length composition of Red Grouper from the SEAMAP Summer Groundfish Survey are shown in **Table 2.42**. A difference in the length composition data from the SEAMAP Summer Groundfish Survey was apparent between SEDAR42 and this assessment, particularly in the first few years (**Table 2.43**). The SEDAR42 length composition included lengths collected during fall, a season which is not included during index development because of inconsistent spatial coverage (SEDAR61-WP-12). For SEDAR61, the DW/AW Panel recommended using only length data collected during summer.

### **2.5.2 NMFS Bottom Longline Survey**

The NMFS Mississippi Laboratories have conducted standardized bottom longline surveys in the Gulf of Mexico, Caribbean, and Western North Atlantic since 1995. The objective of these surveys is to provide fisheries independent data for stock assessment purposes. These surveys are conducted annually and provide an important source of fisheries independent information on large coastal sharks, snappers and groupers from the GOM and Atlantic. In 2011, a Congressional Supplement Sampling Program was conducted where high levels of survey effort were maintained from April through October. For this analysis, only Congressional Supplement Sampling Program data collected during the same time period as the annual survey (August/September) were used to supplement missing data from the NMFS Bottom Longline Survey in 2011.

As in SEDAR61, a standardized index was developed using NMFS Bottom Longline Survey data using standard delta-lognormal methods (SEDAR61-WP-02; **Figure 2.30**). Data from 1995 through 2000 were not used due to the use of J-type hooks, attributing to very few Red Grouper (53) being captured. When the hook type was changed to circle-hooks, Red Grouper catch increased by an order of magnitude (Ingram et al. 2005). Survey year 2002 was dropped from the analysis because of the limited spatial coverage in the eastern Gulf of Mexico (SEDAR61-WP-02, Appendix Figure 1). All SEDAR61 index values fell within the confidence interval for the SEDAR42 index (**Figure 2.30A**), and the trends between indices were similar (**Figure 2.30B**). Relative abundance peaked in 2011, and has declined since, with the lowest level identified in 2016 (**Table 2.41**).

Length composition of Red Grouper from the NMFS Bottom Longline Survey are shown in **Table 2.44**. Length composition was nearly identical between SEDAR61 and SEDAR42 and this assessment (**Table 2.45**).

### **2.5.3 Combined Video Survey**



Currently there are three different stationary video surveys for reef fish conducted in the northern GOM. The SEAMAP Reef Fish Video Survey has the longest running time series (1992-1997, 2002, and 2004+), followed by the NMFS Panama City Video Survey (2005+). The Florida Fish and Wildlife Research Institute (FWRI) added a video survey in 2008. While the surveys use standardized deployment, camera field of view, and fish abundance methods to assess fish abundances on reef or structured habitat, there are variations in survey design and habitat characteristics collected in addition to differences in the time period and area sampled.

Initially for SEDAR42, indices of relative abundance were provided separately for each video survey (SEDAR42 DW-11 for SEAMAP Reef Fish Video Survey; SEDAR42-DW-15 for NMFS Panama City Video Survey; SEDAR42-DW-08 for FWRI Video Survey). Following the SEDAR42 Data Workshop, an index of abundance from a Combined Video Survey using all three datasets was recommended for use by the Index Working Group to improve spatial coverage. Specifically, it was determined at the SEDAR42 Data Workshop that each survey: (1) sampled similar sizes and ages of Red Grouper; (2) used similar gear and video processing methods; and (3) had concurrent sampling since 2008. By covering a larger proportion of the West Florida Shelf (**Figure 2.31**), it was concluded that the combined index provided the best, most comprehensive information on population trends in the northeast Gulf. Combining indices across datasets likely increases predictive capabilities by allowing for the largest possible sample sizes in model fitting.

Since SEDAR42, substantial improvements have been made in the methodology for developing the index of abundance for the Combined Video Survey. For SEDAR61, a habitat-based approach was used to combine data from all three surveys (**Table 2.46**). For this approach, a habitat variable was created for each Lab to account for changing effort and habitat allocation through time rather than limiting the model to be predicted only by year and lab. A categorical regression tree approach (CART) was used to determine the percentage of sites that occurred on good, fair, or poor habitats for each survey independently (SEDAR61-WP-03).

The final index model, assuming a negative binomial distribution, was:

$$MaxN = Year \times Hab \times Lab$$

where *Hab* is the CART derived habitat code and *Lab* represents the survey that collected the data for each site. To account for the variation in survey area, differences in area mapped with known habitat, and the distribution of fair, good, and poor habitats by survey by year, the estimated MaxN means provided by the model were adjusted. The known potential survey universe for each of the three was first multiplied by the proportion of habitat mapping grids that had reef habitat to provide an area weight (**Table 2.47**). This was then multiplied by each *Year x Lab x Hab* combination (up to nine for the final years with three surveys and three habitat levels), providing a weighting factor for each of the mean estimates. Weighted index values were then standardized to the grand mean following standard SEDAR protocols. Additional details are provided in SEDAR61-WP-03.

The trend in the index of relative abundance from the Combined Video Survey was generally similar between the SEDAR42 and SEDAR61 indices (**Figure 2.32**), although some differences

were noted between the SEDAR61 continuity index and the index updated using the habitat-based methodology due to changes in data filtering. For most years, the SEDAR61 index using the habitat-based methodology fell within the confidence intervals of the SEDAR42 index, with the exception of 2008 and 2009 (**Figure 2.32A**). The SEDAR61 index using the habitat-based approach shows initially low catches in the NMFS SEAMAP survey (**Figure 2.32B**). Following a peak in abundance in 2004, CPUE declines until 2007 and then increases until 2009. Abundance generally declines until 2015, with some evidence of increasing relative abundance in 2016 and stability in 2017. Relative abundance reached the lowest level in 2015 (**Table 2.41**).

During SEDAR42, the length composition for the Combined Video Survey was derived from the NMFS SEAMAP and Panama City Laboratory Surveys and did not include length observations from FWRI. For SEDAR61, length data were available for all three sources. Length data from FWRI were subset to NMFS Shrimp Statistical Zones 4 and 5 (**Figure 2.1**) since the Combined Video Survey only used these strata due to insufficient sampling in the other areas of the WFS. After observing no distinct differences in mean length and SE over time (**Figure 2.33**), the lengths from all three sources were combined.

Length composition of Red Grouper from the Combined Video Survey are shown in **Table 2.48**. Small differences in length composition were evident between SEDAR61 and SEDAR42 and this assessment (**Table 2.49**), largely due to the inclusion of FWRI samples for SEDAR61.

#### ***2.5.4 FWRI Hook and Line Repetitive Time Drop Survey***

FWRI has been working collaboratively with scientists from NMFS to expand regional monitoring capabilities and provide timely fisheries-independent data for a variety of state- and federally-managed reef fishes. The repetitive time drop (RTD) survey was selected for use in the SEDAR61 stock assessment due to its coverage of prime Red Grouper habitat and size composition.

Sampling was conducted in the NMFS Shrimp Statistical Zones 4, 5, 9, and 10 in the eastern Gulf of Mexico during 2014 (108 RTD samples) and 2015 (105 RTD samples). In 2016 (98 RTD samples) and 2017 (76 RTD samples), sampling was widened to include reef habitat spanning the entire Gulf coast of Florida (NMFS Shrimp Statistical Zones 2-10; **Figure 2.34**). Sampling locations were selected using a stratified-random sampling design with sampling effort proportional to available habitat within each statistical zone and depth stratum (nearshore, 9-36 m; offshore, 37-109 m; and deep, 110-180 m).

Sampling was conducted using powered reels with a lead weight at the base of each rig. At each station, three anglers simultaneously dropped their rigs to the bottom and actively fished for no more than two minutes. If a fish was hooked before two minutes had elapsed, the angler would retrieve, identify and measure the fish, rebait their hooks and wait until the next team drop before redeploying. Simultaneous team drops were repeated ten times at each station. Three hook sizes were used at each sampling station: one angler fished two 8/0 hooks, another fished with two 11/0 hooks, and a third fished with two 15/0 hooks. Since effort was the same across all stations sampled (number of team drops and number of hooks), the total catch at each station was

modeled as fish captured from all hook sizes at a station combined. Additional details are provided in SEDAR61-WP-11.

The final zero-inflated negative binomial index model was:  $Total = Year + Depth + Statistical\ Zone$ . Although latitude, longitude, and geofom (from side-scan sonar) were considered as variables, they were excluded from the final model due to convergence issues. No concerning trends in residuals were noted, indicating correspondence of underlying model assumptions. Although the time series is relatively short in temporal scale, limiting the inferences that can be discerned concerning patterns of overall Red Grouper population abundance, this index was included in the assessment given the concern over the Red Grouper stock in recent years. Relative abundance has declined since 2014 (**Table 2.41; Figure 2.35**).

Length composition of Red Grouper from the FWRI Hook and Line Repetitive Time Drop Survey are shown in **Table 2.50**.

## 2.6 Environmental Considerations

Red tide blooms caused by the dinoflagellate *Karenia brevis* are common occurrences on the West Florida Shelf and can threaten local tourism and fauna and lead to extirpation of shallow-water (< 40 m) reef biota when severe (Smith 1975). Although fish kill observations often originate from beach sightings, blooms can impact offshore species as well, as blooms generally start offshore at depth (Steidinger and Vargo 1988) and are transported into near-shore areas by winds and tidal currents (Steidinger and Haddad 1981). Members of the shallow-water grouper complex are notably affected by red tide events. Anecdotal evidence of groupers within fish kills was documented in 1971 off Sarasota, Florida, and consisted of Atlantic Goliath Grouper *Epinephelus itajara*, Red Grouper *E. morio*, Gag Grouper *Mycteroperca microlepis*, and Scamp *M. phenax* (see Table 1, Smith 1975). More recently, Red Grouper were observed in floating fish kills in 2005 during the NMFS Bottom Longline Survey (Walter et al. 2013) and in 2014 during surveys conducted by the NMFS Panama City Laboratory (D. DeVries, pers. comm). In addition, Driggers et al. (2016) observed many unidentifiable, large, deep-bodied, decomposing fishes floating at the surface in 2014. Based on their abundance in past years at the site, they hypothesized these individuals were Red Grouper. Most recently in 2018, images of dead serranids including Goliath grouper and Red Grouper dominated social media posts and news programs.

### 2.6.1 Index of red tide severity

To account for red tide mortality in the SEDAR42 assessment model, a binary index of red tide severity (1998-2010) (Walter et al. 2013) was used to identify years where red tides were severe. For SEDAR61, the update of this index required a switch from the Seaviewing Wide Field-of-view Sensor (SeaWiFS) satellite data (ended in December 2010) to Moderate Resolution Imaging Spectroradiometer (MODIS) satellite data (SEDAR61-WP-07). While an updated index was developed (**Figure 2.36**), which showed that no other red tides in the time series reached the severity of the 2005 event, its utility was cautioned due to concerns over calibration between data sources. The MODIS data displayed high variability and derived satellite products (e.g.,

chlorophyll anomaly) correlated poorly with derived products using SeaWiFS data. Research is ongoing to further refine the red tide index using MODIS satellite data.

### 2.6.2 Index of red tide mortality – New Data

An index of red tide mortality was also presented that integrated information describing the spatial extent, duration, and severity of blooms with Red Grouper distribution maps (SEDAR61-WP-06). While considered new data for SEDAR61, a similar analysis for Gulf of Mexico Gag Grouper accompanied the Gulf of Mexico Fishery Management Council (GMFMC) Scientific and Statistical Committee's (SSC) review of the 2014 assessment (SEDAR33 2014) and was used to support the GMFMC SSC's decision to not account for extra mortality due to red tide in 2014 due to minimal spatial overlap. This spatially explicit approach uses synoptic satellite imagery to define the spatial extent of blooms, in situ *K. brevis* cell concentrations (cells/liter) to approximate the severity, a spatially explicit ecosystem model to provide the spatial distribution patterns of Red Grouper, and a logistic mortality response function to impose mortality in each map cell. Below is a brief review of the key steps of the analysis detailed in SEDAR61-WP-06.

In this analysis, Fluorescent Line Height imagery was first used to identify the location of potential harmful algal blooms based on a threshold of  $0.02 \text{ mW cm}^{-2} \mu\text{m}^{-1} \text{ sr}^{-1}$  (SEDAR61-WP-06). These blooms were then validated using in situ *K. brevis* cell concentrations (cells/L) collected by FWRI-HAB. *K. brevis* cell concentration (cells/L) data were interpolated over the entire West Florida Shelf using ordinary kriging. The kriged maps were clipped to the HAB polygons identified by the Fluorescent Line Height detection threshold of 0.02 and resampled to match the resolution of the Red Grouper distribution maps, which were predicted by the spatial component Ecospace of the West Florida Shelf Ecopath with Ecosim Ecosystem Model (Chagaris et al. 2015) for 0-1 year olds, 1-3 year olds, and 4+ year olds. In the West Florida Shelf Ecospace model, Red Grouper were distributed spatially based on relationships to depth and rugosity (as a proxy for bottom structure), and also food availability, and proximity to earlier life stages.

A logistic function was used to determine the proportion of biomass that was killed in each grid cell during each month. The shape of the response function was estimated in order to produce the "known" mortality (i.e. proportion of biomass killed) caused by the 2005 red tide bloom as estimated by the SEDAR42 stock assessment (0.438, 19,731 of 45,012 metric tons). For each month, the response function was applied to determine the proportion of biomass killed in each map cell, which was then multiplied by the biomass of each age stanza in that cell. The red tide mortality for each year was then calculated as the proportion of biomass killed, total and by age stanza, over the entire year divided by the biomass at the start of the year. To account for uncertainty in cell concentrations, eight response functions were used to predict the mortality due to red tides (**Figure 2.37**).

This analysis concluded that for Red Grouper the percent of total biomass killed by red tides has likely been low in all years since 2002, with the exception of 2005. The 2005 red tide event appeared to negatively impact all age classes equally, whereas the estimated mortality was disproportionately higher for younger age stanzas during more recent red tides (**Figure 2.6.2**). The elevated pattern of high mortality on younger ages beginning in 2011 is concerning because

it could potentially be impacting current recruitment levels. Some caveats and uncertainties associated with this analysis were noted by the SEDAR61 DW/AW Panel that require additional research, such as the limitations associated with sea surface satellite imagery, the need to account for autocorrelation in the kriging, and the need to validate the spatial distribution maps used with empirical data. Further, bloom toxicity is not well correlated with cell concentrations, such that high *K. brevis* concentrations do not always lead to fish kills and low concentrations may result in large fish kills.

### **2.6.3 Treatment of the 2014 and 2015 Red Tide Events**

At the SEDAR61 DW/AW Workshop, considerable discussion surrounded the magnitude of the 2014 red tide event and how to incorporate it into the assessment model. While the 2014 event appeared minimal for the Red Grouper stock based on the red tide index updated with MODIS (**Section 2.6.1**) and the ecosystem analysis (**Section 2.6.2**), a more severe impact of the 2014 event was emphasized by observers, most notably fishermen in attendance that regularly fish in the affected region as well as participants in the GMFMC voluntary online data collection tool (see **Section 2.7**). Regarding both red tide analyses discussed above, future research was recommended by the DW/AW Panel before either continuous index could be explicitly incorporated into the stock assessment. Given the discussions surrounding the 2014 red tide event, the DW/AW Panel recommended treating the 2014 red tide event as severe in the continuity model but conducting a sensitivity run that assumed negligible impact of the 2014 red tide event. During the SEDAR61 DW/AW Workshop very little discussion surround the 2015 red tide event, and therefore it was assumed negligible in the continuity model but considered in a sensitivity run. Lastly, while the 2018 red tide event was discussed in some detail, at the time of the workshop (September 2018) there was still considerable uncertainty surrounding its impacts. Since 2018 is the first year of projections, the 2018 red tide event is discussed in more detail in **Section 5.2**.

## **2.7 Contributions from Stakeholders**

Prior to the SEDAR61 DW/AW Workshop in September 2018, the GMFMC hosted a voluntary data collection tool titled “Something’s Fishy with Red Grouper.” The intent of this tool was to collect anecdotal data from fishermen regarding Red Grouper, with a particular focus on both their occurrence in fish kills due to red tides and regulatory discards. While responses were open-ended, instructions were to discuss “anything “fishy” about red grouper fishing in recent years.” The majority of respondents were private recreational anglers (**Figure 2.38A**) and from NMFS Shrimp Statistical Zones 4 through 6 (**Figure 2.38B, Figure 2.1**). A summary of the results was presented during SEDAR61, with key findings including:

- Legal-size and larger Red Grouper are found deeper than they have been historically;
- There are fewer legal-size Red Grouper in recent years;
- There are more small Red Grouper now than there have been historically;
- The population hasn’t recovered since the 2014 red tide event;
- Red Grouper may shift location due to storms like tropical cyclones;
- Red Grouper are being displaced by Red Snapper (*Lutjanus campechanus*);
- Other species including lionfish (*Pterois* sp.), sharks, and Atlantic Goliath Grouper may be negatively impacting the stock; and

- Depredation on Red Grouper discards is increasing.

Many observations of dead Red Grouper due to suspected red tide were noted, particularly within NMFS Shrimp Statistical Zones 4 through 6 (**Figure 2.38C, Figure 2.1**). Of the 10 respondents that mentioned a specific year or time-frame in their answer where episodic mortality due to suspected red tides was observed, most highlighted thousands of dead Red Grouper during the 2014-2015 event. While the majority of respondents expressed concerns over observing reduced abundance or an inability to catch Red Grouper, a fair number of respondents reported optimism via large numbers of sub-legal Red Grouper being discarded (**Figure 2.38D**).

## 2.8 References

- Chagaris, D.D., B. Mahmoudi, C.J. Walters, and M.S. Allen. 2015. Simulating the trophic impacts of fishery policy options on the West Florida Shelf using Ecopath with Ecosim. *Marine and Coastal Fisheries* 7(1):44-58.
- Chih, C-P. 2009. Evaluation of the sampling efficiency of three otolith sampling methods for commercial king mackerel fisheries. *Transactions of the American Fisheries Society* 138:990-999.
- Chih, C-P. 2014. Variations in length frequency distributions and age length keys for red groupers collected in the Gulf of Mexico. SEDAR42-DW-12. SEDAR, North Charleston, SC. 26 pp.
- Diaz, G.A., C.E. Porch, and M. Ortiz. 2004. Growth models for red snapper in U.S. Gulf of Mexico waters estimated from landings with minimum size limit restrictions. NMFS/SEFSC/SFD 2004-038, 13 p.
- Driggers, W.B., M.D. Campbell, A.J. Debose, K.M. Hannan, M.D. Hendon, T.L. Martin and C.C. Nichols. 2016. Environmental conditions and catch rates of predatory fishes associated with a mass mortality on the West Florida Shelf. *Estuarine Coastal and Shelf Science* 168: 40-49.
- Foster, J. and F.J. Breidt. 2018. APAIS data calibration methodology report. 10 p. Available at: <https://www.fisheries.noaa.gov/event/access-point-angler-intercept-survey-calibration-workshop>
- Hoenig, J.M. 1983. Empirical use of longevity data to estimate natural mortality rates. *Fisheries Bulletin* 82:898-903.
- Ingram, W., T. Henwood, M. Grace, L. Jones, W. Driggers, and K. Mitchell. 2005. Catch rates, distribution and size composition of large coastal sharks collected during NOAA Fisheries Bottom Longline Surveys from the U.S. Gulf of Mexico and U.S. Atlantic Ocean. LCS05/06-DW-27
- Lo, N.C., L.D. Jacobson, and J.L. Squire. 1992. Indices of relative abundance from fish spotter data based on delta-lognormal models. *Canadian Journal of Fisheries and Aquatic Sciences* 49: 2515-2526.

- Lombardi-Carlson, L., G. Fitzhugh, C. Palmer, C. Gardner, R. Farsky, and M. Ortiz. 2008. Regional size, age and growth differences of Red Grouper (*Epinephelus morio*) along the west coast of Florida. *Fisheries Research* 91:239-251.
- Lorenzen, K. 2005. Population dynamics and potential of fisheries stock enhancement: practical theory for assessment and policy analysis. *Philosophical Transactions of the Royal Society of London. Biological Sciences.* 360:171-189.
- Lowerre-Barbieri, S., L. Crabtree, T.S. Switzer, and R. H. McMichael, Jr. 2014. Maturity, sexual transition, and spawning seasonality in the protogynous Red Grouper on the West Florida Shelf. SEDAR42-DW07. SEDAR, North Charleston, SC. 21 pp.
- Nichols, S. 2004. Derivation of red snapper time series from SEAMAP and groundfish trawl surveys. SEDAR7-DW01.
- NOAA Fisheries. 2018. Marine Recreational Information Program Transition Plan for the Fishing Effort Survey. 34 p. Available at: <https://www.fisheries.noaa.gov/event/fishing-effort-survey-calibration-model-peer-review>.
- Pollack, A.G. and G.W. Ingram Jr. 2010. Abundance indices of subadult yellowedge grouper, *Epinephelus flavolimbatus*, collected in summer and fall groundfish surveys in the northern Gulf of Mexico. SEDAR22-DW-06.
- Pulver, J.R., L. Lombardi, and E. Scott-Denton. 2014. Summary of commercial Red Grouper (*Epinephelus morio*) catch data based on fishery observer coverage of the Gulf of Mexico reef fish fishery. SEDAR42-DW-01. SEDAR, North Charleston, SC. 40 pp.
- Rago, P.J, A. Arab, R.L. Hicks, C.M. Jones, J. McNamee, F.M. Serchuk, and P.J. Sullivan. 2017. Summary Report Marine Recreational Information Program (MRIP) Fishing Effort Survey (FES) Calibration Review. 34 p. Available at: <https://www.fisheries.noaa.gov/event/fishing-effort-survey-calibration-model-peer-review>.
- Rios, A. 2015. Standardized catch rates of Red Grouper (*Epinephelus morio*) from the U.S. Headboat Fishery in the Gulf of Mexico, 1986-2013. SEDAR42-AW-03. SEDAR, North Charleston, SC. 14 pp.
- Sauls, B., O. Ayala, and R. Cody. 2014. A directed study of the recreational red snapper fisheries in the Gulf of Mexico along the west Florida shelf – Final Project Report. SEDAR42-RD-01. 100 pp.
- Smith, G.B. 1975. The 1971 red tide and its impact on certain reef communities in the mid-eastern Gulf of Mexico. *Environmental Letters* 9(2):141-152.

SEDAR (Southeast Data Assessment and Review). 2006. SEDAR12: Gulf of Mexico Red Grouper Stock Assessment Report. SEDAR, North Charleston, SC. 358 p. Available at: <http://sedarweb.org/sedar-12>.

SEDAR (Southeast Data Assessment and Review). 2009. SEDAR12 Update: Gulf of Mexico Red Grouper Stock Assessment Report. SEDAR, North Charleston, SC. 143 p. Available at: <http://sedarweb.org/sedar-12>.

SEDAR (Southeast Data Assessment and Review). 2010. SEDAR19: South Atlantic Red Grouper Stock Assessment Report. SEDAR, North Charleston, SC. 612 p. Available at: <http://sedarweb.org/sedar-19>.

SEDAR (Southeast Data Assessment and Review). 2014. SEDAR33: Gulf of Mexico Gag Grouper Stock Assessment Report. SEDAR, North Charleston, SC. 609 p. Available at: <http://sedarweb.org/sedar-33>.

SEDAR (Southeast Data Assessment and Review). 2015. SEDAR42: Gulf of Mexico Red Grouper Stock Assessment Report. SEDAR, North Charleston, SC. 612 p. Available at: <http://sedarweb.org/sedar-42>.

SERO (Southeast Regional Office). 2017. Minimum stock size threshold (MSST) revision for reef fish stocks with existing status determination criteria. Tampa, FL. 123p. Available from: [http://sero.nmfs.noaa.gov/sustainable\\_fisheries/gulf\\_fisheries/reef\\_fish/2017/am44\\_reef\\_fish\\_MSST/index.html](http://sero.nmfs.noaa.gov/sustainable_fisheries/gulf_fisheries/reef_fish/2017/am44_reef_fish_MSST/index.html)

Steidinger, K.A., and Haddad, K. 1981. Biologic and hydrographic aspects of red tides. *Bioscience* 1981:814-819.

Steidinger, K.A., and Vargo, G.A. 1988. Marine dinoflagellate blooms: dynamics and impacts. In *Algae and Human Affairs*. Edited by C. Lembi and J.R. Waaland Cambridge University Press. pp. 373-401.

Stephens, A. and A. MacCall. 2004. A multispecies approach to subsetting logbook data for purposes of estimating CPUE. *Fisheries Research* 70:299-310.

Walter, J., M.C. Christman, J.H. Landsberg, B. Linton., K. Steidinger, R. Stumpf, and J. Tustison. 2013. Satellite derived indices of red tide severity for input for Gulf of Mexico Gag grouper stock assessment. SEDAR33-DW08, SEDAR, North Charleston, SC. 43 p.



## 2.9 Tables

**Table 2.1.** The number of Red Grouper otoliths aged for SEDAR61 by year and data provider. Data providers include NMFS Panama City Laboratory Age, Growth and Reproduction database (NMFS PC-AGR), NMFS Panama City Laboratory Biological Sampling Database (NMFS PC-BSD), Florida Fish and Wildlife Conservation Commission, Florida Wildlife and Research Institute Fisheries Independent Monitoring (FWRI-FIM), Gulf States Marine Fisheries Commission Fisheries Information Network (GulfFIN), and the University of South Florida (USF).

Year	NMFS PC-AGR	NMFS PC-BSD	FWRI- FIM	GulfFIN	USF	Total
1979	71					71
1980	8					8
1981	301					301
1985	1					1
1986	8					8
1987	11					11
1988	10					10
1989	11					11
1991	119					119
1992	268					268
1993	494					494
1994	519					519
1995	528					528
1996	431					431
1997	158					158
1998	299					299
1999	885					885
2000	794					794
2001	2,049					2,049
2002	2,127			5		2,132
2003	2,015			6		2,021
2004	2,877			14		2,891
2005	2,403			3		2,406
2006	1,524		82	5		1,611
2007	1,363		193	2		1,558
2008	1,413		80			1,493
2009	4,536		321	1		4,858
2010	2,450		946	7		3,403
2011	2,278	1,145	502	8	364	4,297
2012	1,166	1,331	541	2		3,040
2013	998	1,159	807			2,964
2014	576	1,366	529	2		2,473
2015	387	1,119	440	302		2,248
2016	156	1,155	343	361		2,015
2017	82	1,085	511	234		1,912
<b>Total</b>	<b>33,316</b>	<b>8,360</b>	<b>5295</b>	<b>952</b>	<b>364</b>	<b>48,287</b>
<b>Percent</b>	<b>69.0%</b>	<b>17.3%</b>	<b>11.0%</b>	<b>2.0%</b>	<b>0.8%</b>	

**Table 2.2.** The number of Red Grouper newly aged and submitted for SEDAR61 by year and data provider. Data providers are as defined in **Table 2.1**.

Year	NMFS PC - AGR	NMFS PC-BSD	FWRI-FIM	GulfFIN	USF	Total
2009			2			2
2010			1			1
2011			1		364	365
2012			11			11
2013	20		8			28
2014	549	1366	538	2		2455
2015	387	1119	444	302		2252
2016	156	1155	343	361		2015
2017	82	1085	511	234		1912
Total	1194	4725	1859	899	364	9041
Percent	13.2%	52.3%	20.6%	9.9%	4.0%	

**Table 2.3.** Comparison of age-growth data for Red Grouper used to develop the growth curves for SEDAR61 and SEDAR42.

Age	SEDAR42	SEDAR61	Number of new records	Percentage of new records
0	16	24	8	50
1	255	357	102	40
2	652	960	308	47
3	2,023	2,389	366	18
4	3,407	3,850	443	13
5	6,308	7,248	940	15
6	7,196	7,985	789	11
7	6,375	7,741	1,366	21
8	4,266	5,676	1,410	33
9	2,964	4,031	1,067	36
10	1,969	2,735	766	39
11	1,180	1,666	486	41
12	682	919	237	35
13	483	650	167	35
14	319	456	137	43
15	210	308	98	47
16	137	202	65	47
17	96	133	37	39
18	77	116	39	51
19	58	75	17	29
20	41	47	6	15
21	31	36	5	16
22	13	14	1	8
23	10	14	4	40
24	19	19	0	0
25	14	16	2	14
26	3	4	1	33
27	6	6	0	0
28	2	2	0	0
29	1	1	0	0
Total	38,813	47,680	8,867	-

**Table 2.4.** Resulting age-specific natural mortality (M) vectors for Red Grouper as revised for SEDAR61 and previous assessments. Each vector was calculated using the same regression (Lorenzen 2005), age 5 as the first age at vulnerability, and a target M of 0.14 ( $M_{\text{teleost}}$ , maximum age of 29 years). The only difference among the age-specific natural mortality vectors was the predicted von Bertalanffy growth parameters used in the estimations.

Age	SEDAR61	SEDAR42	SEDAR12Update	SEDAR12
0	0.5576	0.5837	0.6309	1.0000
1	0.3817	0.3952	0.4092	0.4943
2	0.2996	0.3082	0.3137	0.3391
3	0.2522	0.2583	0.2606	0.2681
4	0.2216	0.2261	0.2269	0.2277
5	0.2002	0.2036	0.2038	0.2018
6	0.1846	0.1873	0.1871	0.1840
7	0.1728	0.1749	0.1745	0.1712
8	0.1637	0.1652	0.1648	0.1616
9	0.1564	0.1576	0.1571	0.1542
10	0.1505	0.1514	0.1510	0.1484
11	0.1457	0.1463	0.1459	0.1438
12	0.1418	0.1421	0.1418	0.1401
13	0.1385	0.1386	0.1383	0.1371
14	0.1357	0.1356	0.1354	0.1347
15	0.1334	0.1331	0.1330	0.1327
16	0.1314	0.1310	0.1309	0.1310
17	0.1297	0.1291	0.1291	0.1296
18	0.1282	0.1276	0.1276	0.1284
19	0.1270	0.1262	0.1263	0.1274
20	0.1259	0.1250	0.1252	0.1266
21	0.1250	0.1240	0.1242	0.1259
22	0.1242	0.1231	0.1234	0.1254
23	0.1235	0.1224	0.1227	0.1249
24	0.1229	0.1217	0.1220	0.1244
25	0.1224	0.1211	0.1215	0.1241
26	0.1219	0.1206	0.1210	0.1238
27	0.1215	0.1202	0.1206	0.1235
28	0.1212	0.1198	0.1202	0.1233
29	0.1209	0.1194	0.1199	0.1231

**Table 2.5.** Comparison of commercial vertical line and longline discard mortality estimates (DM) for Red Grouper from SEDAR42 (2010-2013 post-Individual Fishing Quotas) to results with updated Reef Fish Observer Program observer data from 2010 to 2017 (SEDAR61). Additional details on the methodology are provided in Pulver et al. (2014).

	SEDAR42	SEDAR61
	Longline	
Weighted Mean Immediate DM Rate	29.5%	30.1%
Weighted Mean DM with additional 20% Latent Mortality	43.6%	<b>44.1%</b>
Weighted Mean DM with additional 10% Latent Mortality	36.7%	37.1%
Weighted Mean DM with additional 30% Latent Mortality	50.8%	51.1%
Observer Data Fishing Years	2010-2013	2010-2017
Number of Fishing Sets Observed with Discards	4,983	7,014
	Vertical Line	
Weighted Mean Immediate DM Rate	13.8%	13.5%
Point DM Estimate based on FWC 40-50 m value	19.0%	<b>19.0%</b>
Weighted Mean DM with additional 20% Latent Mortality	31.0%	30.8%
SEDAR12 DM Estimate	10.0%	10.0%
Observer Data Fishing Years	2010-2013	2010-2017
Number of Fishing Sets Observed with Discards	5,902	9,086

**Table 2.6.** Estimates of discard mortality used for Red Grouper in SEDAR61. Values in bold were updated for SEDAR61 (see **Table 2.5**).

Fleet	SEDAR12	SEDAR42	SEDAR61
Recreational	10%	11.6%	11.6%
Commercial Vertical Line	10%	19.0%	<b>19.0%</b>
Commercial Longline Pre-IFQ	40%	41.4%	41.4%
Commercial Longline Post-IFQ	40%	43.6%	<b>44.1%</b>
Commercial Trap	10%	10%	10%

**Table 2.7.** Comparison of maturity and sexual transition estimates for Red Grouper between SEDAR42 and SEDAR61. N = Number, FL = Fork Length.

Parameter	SEDAR42	SEDAR61
Age at 50% maturity	2.8 years (N = 1,559)	2.2 years (N = 2,069)
Size at 50% maturity	292 mm FL (N = 1,677)	278 mm FL (N = 2,189)
Age at 50% sexual transition	11.2 years (N = 5,381)	11.4 years (N = 7,296)
Size at 50% sexual transition	707 mm FL (N = 5,775)	708 mm FL (N = 7,766)

**Table 2.8.** Commercial landings of Gulf of Mexico Red Grouper in pounds gutted weight. Landings after 1993 were adjusted by logbook for gear and area; IFQ adjusted 2010-2017.

Year	Vertical line	Longline	Other	Trap	Total
1963	3,564,592	0	2,884	0	3,567,476
1964	4,140,338	0	13,769	4,628	4,158,735
1965	4,616,945	0	0	5,053	4,621,998
1966	4,433,396	0	1,093	6,553	4,441,042
1967	3,583,388	0	15,447	7,404	3,606,239
1968	3,942,688	0	3,205	13,511	3,959,403
1969	4,587,309	0	2,056	7,804	4,597,170
1970	4,469,105	0	0	12,160	4,481,264
1971	3,812,225	0	0	12,149	3,824,374
1972	3,963,622	0	10	2,277	3,965,908
1973	3,059,028	0	530	0	3,059,558
1974	3,568,782	0	827	0	3,569,609
1975	4,312,414	0	163	12,426	4,325,003
1976	3,727,297	0	0	11,404	3,738,701
1977	2,977,567	0	4,514	41,873	3,023,954
1978	2,731,138	0	5,628	88,893	2,825,658
1979	3,778,962	0	0	70,135	3,849,096
1980	3,847,616	0	10,672	44,773	3,903,060
1981	3,324,172	3	9,827	66,685	3,400,688
1982	3,074,037	815,663	12,994	50,020	3,952,714
1983	2,907,533	3,064,216	12,650	1,109	5,985,509
1984	2,947,579	2,487,094	3,349	311,570	5,749,592
1985	3,647,830	2,073,122	7,282	640,413	6,368,646
1986	3,134,859	2,505,832	11,217	721,461	6,373,369
1987	2,542,122	3,774,849	11,082	448,081	6,776,135
1988	2,049,120	2,192,793	5,228	540,228	4,787,369
1989	3,814,892	3,118,201	11,051	592,772	7,536,916
1990	2,460,952	2,025,693	5,346	340,896	4,832,887
1991	2,093,837	2,583,586	33,887	373,747	5,085,058
1992	1,444,966	2,409,550	8,636	602,185	4,465,337
1993	1,300,324	4,274,356	43,275	711,086	6,329,042
1994	1,241,427	2,699,085	37,682	913,825	4,892,020
1995	1,171,250	2,429,416	16,044	1,056,993	4,673,703
1996	865,153	2,907,190	10,161	539,359	4,321,863
1997	948,379	3,024,185	6,839	685,831	4,665,234
1998	741,606	2,662,278	5,128	297,548	3,706,560
1999	1,212,757	3,815,403	17,430	751,819	5,797,410

**Table 2.8. Continued** Gulf of Mexico Red Grouper Commercial Landings

Year	Vertical line	Longline	Other	Trap	Total
2000	1,720,988	2,909,341	30,399	1,024,809	5,685,537
2001	1,555,714	3,399,634	21,255	743,289	5,719,892
2002	1,628,178	3,130,561	18,484	980,293	5,757,516
2003	1,118,263	2,964,737	12,313	701,668	4,796,981
2004	1,376,656	3,383,468	14,130	745,209	5,519,462
2005	1,404,240	3,211,570	12,402	612,717	5,240,929
2006	1,375,688	3,012,663	8,956	586,847	4,984,154
2007	1,561,080	1,984,386	13,097	24,476	3,583,039
2008	1,888,195	2,804,101	24,772	0	4,717,069
2009	2,445,472	1,124,980	121,738	0	3,692,190
2010	1,352,746	1,313,484	275,399	0	2,941,629
2011	1,683,963	3,049,498	50,192	15	4,783,668
2012	2,228,739	2,940,844	49,550	0	5,219,133
2013	1,532,418	3,025,903	40,680	0	4,599,001
2014	1,910,749	3,532,923	157,472	0	5,601,144
2015	1,854,306	2,837,057	105,796	0	4,797,159
2016	1,212,438	3,166,180	118,964	0	4,497,582
2017	990,340	2,297,303	40,628	0	3,328,271
Percent	72.95%	23.11%	0.34%	3.60%	-

**Table 2.9.** Sample sizes by region of the West Florida Shelf for length samples of Red Grouper collected between 1984 and 2017 from commercial fisheries in the Gulf of Mexico.

Year	Vertical Line			Longline			Trap			Total
	North	South	Total	North	South	Total	North	South	Total	
1984	161	1,209	1,370	107	1,014	1,121		18	18	2,509
1985	39	2,012	2,051	537	1,152	1,689		1,185	1,185	4,925
1986	10	513	523	242	5,519	5,761		1,244	1,244	7,528
1987	7	1,099	1,106	75	2,483	2,558		766	766	4,430
1988		1,137	1,137	146	1,229	1,375			0	2,512
1989	18	592	610		1,617	1,617		341	341	2,568
1990	114	831	945	999	9,795	10,794		359	359	12,098
1991	158	1,681	1,839	1,351	10,942	12,293	43	348	391	14,523
1992	447	1,999	2,446	115	8,283	8,398	196	647	843	11,687
1993	1,123	1,387	2,510	1,453	8,239	9,692	4	438	442	12,644
1994	1,072	2,163	3,235	1,146	7,027	8,173		207	207	11,615
1995	1,873	1,394	3,267	2,511	8,597	11,108		342	342	14,717
1996	1,251	1,843	3,094	2,901	6,855	9,756	367	287	654	13,504
1997	1,376	1,040	2,416	4,743	8,896	13,639	1,159	363	1,522	17,577
1998	1,274	2,205	3,479	4,812	24,146	28,958	638	422	1,060	33,497
1999	3,227	3,489	6,716	6,988	37,233	44,221	1,503	380	1,883	52,820
2000	2,884	4,869	7,753	5,069	24,949	30,018	2,185	517	2,702	40,473
2001	3,413	3,545	6,958	3,629	16,351	19,980	3,096	866	3,962	30,900
2002	2,702	2,758	5,460	2,699	15,442	18,141	1,689	489	2,178	25,779
2003	1,565	1,377	2,942	1,436	12,246	13,682	1,209	133	1,342	17,966
2004	1,553	1,228	2,781	1,155	9,800	10,955	20	364	384	14,120
2005	1,298	585	1,883	1,839	5,821	7,660	377	205	582	10,125
2006	647	172	819	1,443	3,036	4,479	803	186	989	6,287
2007	1,268	94	1,362	522	2,368	2,890				4,252
2008	1,178	305	1,483	1,154	3,499	4,653				6,136
2009	2,508	1,390	3,898	314	1,653	1,967				5,865
2010	1,186	2,138	3,324	372	1,995	2,367				5,691
2011	4,753	1,355	6,108	1,322	3,179	4,501				10,609
2012	7,429	3,238	10,667	2,443	4,680	7,123				17,790
2013	6,461	3,461	9,922	1,436	5,597	7,033				16,955
2014	3,613	2,675	6,288	769	5,707	6,476				12,764
2015	1,827	2,862	4,689	875	3,520	4,395				9,084
2016	1,785	1,443	3,228	792	4,474	5,266				8,494
2017	1,758	1,080	2,838	735	3,261	3,996				6,834



**Table 2.10.** Sample sizes by region of the West Florida Shelf for age samples of Red Grouper collected between 1991 and 2017 from commercial fisheries in the Gulf of Mexico.

Year	Vertical Line			Longline			Trap			Total
	North	South	Total	North	South	Total	North	South	Total	
1991	28	15	43	35	2	37		2	2	82
1992	20	22	42	1	136	137	14		14	193
1993	81	12	93	10	190	200		84	84	377
1994	183	55	238	24	64	88		29	29	355
1995	178	2	180	14	126	140		39	39	359
1996	79	6	85		96	96		8	8	189
1997	35		35		7	7		17	17	59
1998	17	22	39	37	85	122		33	33	194
1999	53	24	77	96	547	643		31	31	751
2000	144	62	206	137	268	405		38	38	649
2001	370	211	581	880	342	1,222	5	35	40	1,843
2002	155	417	572	607	460	1,067	11	78	89	1,728
2003	314	247	561	234	846	1,080	39	26	65	1,706
2004	528	526	1,054	200	914	1,114		36	36	2,204
2005	399	228	627	269	1,187	1,456			0	2,083
2006	299	330	629	163	375	538	82	91	173	1,340
2007	436	61	497	144	452	596				1,093
2008	377	126	503	143	366	509				1,012
2009	519	376	895	111	882	993				1,888
2010	482	548	1,030	103	547	650				1,680
2011	439	188	627	101	398	499				1,126
2012	584	432	1,016	192	669	861				1,877
2013	392	166	558	276	866	1,142				1,700
2014	404	250	654	158	740	898				1,552
2015	417	332	749	130	453	583				1,332
2016	388	214	602	150	436	586				1,188
2017	382	160	542	125	398	523				1,065

**Table 2.11.** Age composition of landed Red Grouper for the commercial vertical line (reweighted by the length frequency to account for non-representative sampling). Adjusted sample sizes (N adj) were obtained by taking the square root of observed sample sizes (N) and rescaling them during the assessment process using the Francis iterative reweighting approach. Data bars indicate the relative magnitude of the annual age frequency.

Year	N	N adj	Age-1	Age-2	Age-3	Age-4	Age-5	Age-6	Age-7	Age-8	Age-9	Age-10	Age-11	Age-12	Age-13	Age-14	Age-15	Age-16	Age-17	Age-18	Age-19	Age-20+
1991	43	9.8	0.00	0.00	0.05	0.02	0.20	0.25	0.06	0.00	0.13	0.20	0.00	0.02	0.02	0.00	0.00	0.01	0.00	0.00	0.01	0.01
1992	42	8.4	0.00	0.00	0.00	0.00	0.35	0.26	0.26	0.09	0.00	0.01	0.01	0.00	0.02	0.00	0.00	0.00	0.00	0.00	0.00	0.00
1993	93	14.1	0.00	0.00	0.00	0.14	0.17	0.27	0.25	0.11	0.02	0.01	0.01	0.00	0.00	0.00	0.00	0.00	0.00	0.00	0.00	0.00
1994	238	21.1	0.00	0.00	0.00	0.13	0.31	0.19	0.16	0.10	0.06	0.02	0.01	0.01	0.00	0.00	0.01	0.00	0.00	0.00	0.00	0.00
1995	180	18.3	0.00	0.00	0.00	0.03	0.18	0.31	0.28	0.09	0.03	0.04	0.03	0.00	0.01	0.00	0.00	0.00	0.00	0.00	0.00	0.00
1996	85	12.6	0.00	0.00	0.00	0.00	0.10	0.39	0.30	0.11	0.10	0.00	0.00	0.00	0.00	0.00	0.00	0.00	0.00	0.00	0.00	0.00
1997	35	8.4	0.00	0.00	0.00	0.02	0.09	0.23	0.32	0.27	0.05	0.01	0.00	0.00	0.00	0.00	0.00	0.00	0.00	0.00	0.00	0.00
1998	39	8.4	0.00	0.00	0.01	0.19	0.15	0.16	0.22	0.15	0.08	0.03	0.00	0.00	0.00	0.01	0.00	0.00	0.00	0.00	0.00	0.00
1999	77	12.6	0.00	0.00	0.00	0.02	0.14	0.24	0.16	0.24	0.12	0.07	0.00	0.01	0.00	0.00	0.00	0.00	0.00	0.00	0.00	0.00
2000	206	19.7	0.00	0.00	0.00	0.25	0.14	0.23	0.10	0.07	0.07	0.04	0.04	0.02	0.02	0.02	0.00	0.00	0.00	0.00	0.00	0.00
2001	581	33.7	0.00	0.00	0.00	0.04	0.36	0.12	0.17	0.10	0.03	0.06	0.04	0.02	0.02	0.01	0.00	0.01	0.00	0.00	0.00	0.00
2002	572	33.7	0.00	0.00	0.01	0.05	0.12	0.36	0.13	0.11	0.08	0.07	0.02	0.03	0.01	0.01	0.00	0.00	0.00	0.00	0.00	0.00
2003	561	33.7	0.00	0.00	0.00	0.09	0.12	0.21	0.27	0.11	0.09	0.03	0.02	0.02	0.01	0.00	0.01	0.00	0.00	0.00	0.00	0.01
2004	1,054	45.0	0.00	0.00	0.00	0.03	0.40	0.13	0.16	0.12	0.05	0.04	0.02	0.01	0.01	0.01	0.01	0.00	0.00	0.00	0.00	0.00
2005	627	35.1	0.00	0.00	0.00	0.00	0.09	0.60	0.08	0.08	0.07	0.02	0.02	0.02	0.01	0.01	0.00	0.00	0.00	0.00	0.00	0.00
2006	629	35.1	0.00	0.00	0.00	0.00	0.02	0.16	0.52	0.15	0.06	0.04	0.02	0.01	0.01	0.01	0.00	0.01	0.00	0.00	0.00	0.01
2007	497	30.9	0.00	0.00	0.00	0.00	0.24	0.08	0.18	0.29	0.10	0.04	0.02	0.02	0.01	0.00	0.00	0.00	0.00	0.00	0.00	0.00
2008	503	30.9	0.00	0.00	0.00	0.00	0.07	0.44	0.10	0.15	0.15	0.03	0.02	0.02	0.01	0.00	0.00	0.00	0.00	0.00	0.00	0.00
2009	895	42.2	0.00	0.00	0.03	0.02	0.10	0.07	0.35	0.12	0.14	0.11	0.03	0.01	0.01	0.00	0.00	0.00	0.00	0.00	0.00	0.01
2010	1,030	45.0	0.00	0.00	0.02	0.17	0.06	0.09	0.15	0.23	0.12	0.09	0.04	0.00	0.01	0.01	0.00	0.00	0.00	0.00	0.00	0.00
2011	627	35.1	0.00	0.00	0.00	0.03	0.51	0.07	0.08	0.07	0.11	0.04	0.04	0.02	0.01	0.00	0.00	0.01	0.00	0.00	0.00	0.00
2012	1,016	45.0	0.00	0.00	0.00	0.01	0.17	0.53	0.07	0.06	0.03	0.05	0.03	0.02	0.02	0.01	0.00	0.00	0.00	0.00	0.00	0.00
2013	558	33.7	0.00	0.00	0.00	0.01	0.05	0.27	0.45	0.07	0.04	0.03	0.02	0.01	0.02	0.01	0.00	0.00	0.00	0.00	0.00	0.00
2014	654	36.5	0.00	0.00	0.00	0.02	0.07	0.07	0.26	0.27	0.10	0.05	0.04	0.04	0.03	0.02	0.02	0.01	0.01	0.01	0.01	0.00
2015	749	37.9	0.00	0.00	0.00	0.01	0.11	0.10	0.09	0.23	0.23	0.07	0.06	0.01	0.03	0.01	0.02	0.01	0.01	0.01	0.01	0.00
2016	602	35.1	0.00	0.00	0.00	0.03	0.04	0.06	0.10	0.12	0.20	0.15	0.10	0.05	0.03	0.02	0.02	0.01	0.02	0.01	0.00	0.02
2017	542	32.3	0.00	0.00	0.02	0.05	0.13	0.09	0.09	0.09	0.11	0.16	0.12	0.05	0.02	0.01	0.04	0.01	0.00	0.01	0.00	0.00

**Table 2.12.** Difference in commercial vertical line age composition of Red Grouper and sample size (N) from the previous assessment (SEDAR61 Value – SEDAR42 Value). Larger differences identified by shading (red: SEDAR61 higher, blue: SEDAR61 lower).

Year	N	Age-1	Age-2	Age-3	Age-4	Age-5	Age-6	Age-7	Age-8	Age-9	Age-10	Age-11	Age-12	Age-13	Age-14	Age-15	Age-16	Age-17	Age-18	Age-19	Age-20	
1991	0	0.000	0.000	0.000	0.000	0.001	0.001	0.000	0.000	0.000	-0.006	-0.001	0.002	0.004	0.000	0.000	0.000	0.000	0.000	0.000	0.000	-0.001
1992	0	0.000	0.000	0.000	0.000	0.081	-0.025	-0.061	0.005	0.000	0.000	0.000	0.000	0.000	0.000	0.000	0.000	0.000	0.000	0.000	0.000	0.000
1993	0	0.000	0.000	0.000	-0.001	0.004	0.000	0.000	-0.004	0.000	0.000	0.000	0.000	0.000	0.000	0.000	0.000	0.000	0.000	0.000	0.000	0.000
1994	-1	0.000	0.000	0.000	0.000	-0.001	0.002	0.000	0.000	0.000	0.000	0.000	0.000	0.000	0.000	0.000	0.000	0.000	0.000	0.000	0.000	0.000
1995	0	0.000	0.000	0.000	0.000	0.000	0.000	-0.001	0.000	0.000	0.000	0.000	0.000	0.000	0.000	0.000	0.000	0.000	0.000	0.000	0.000	0.000
1996	-56	0.000	0.000	0.000	-0.002	-0.013	0.007	0.004	0.002	0.002	0.000	0.000	0.000	0.000	0.000	0.000	0.000	0.000	0.000	0.000	0.000	0.000
1997	0	0.000	0.000	0.000	0.000	0.000	0.000	0.000	0.000	0.000	0.000	0.000	0.000	0.000	0.000	0.000	0.000	0.000	0.000	0.000	0.000	0.000
1998	0	0.000	0.000	0.006	-0.006	0.012	-0.012	-0.006	0.005	0.000	0.000	0.000	0.000	0.000	0.000	0.000	0.000	0.000	0.000	0.000	0.000	0.000
1999	0	0.000	0.000	0.000	0.000	0.000	0.000	0.000	0.000	0.000	0.000	0.000	0.000	0.000	0.000	0.000	0.000	0.000	0.000	0.000	0.000	0.000
2000	0	0.000	0.000	0.000	0.000	0.000	0.000	0.000	-0.004	0.004	-0.015	0.015	-0.009	0.009	0.000	-0.001	0.001	0.000	0.000	0.000	0.000	0.000
2001	6	0.000	0.000	0.000	0.000	0.001	0.000	0.000	0.001	0.000	0.000	0.002	-0.003	0.000	0.000	0.000	0.000	0.000	0.000	0.000	0.000	0.000
2002	-1	0.000	0.000	0.000	0.000	0.000	0.000	0.000	0.000	0.000	0.000	0.001	-0.001	0.000	0.000	0.000	0.000	0.000	0.000	0.000	0.000	0.000
2003	0	0.000	0.000	0.000	-0.006	0.005	0.004	0.003	-0.005	0.003	-0.002	0.000	0.000	-0.001	0.000	0.000	0.000	0.000	0.000	0.000	0.000	-0.001
2004	-8	0.000	0.000	0.000	-0.001	0.002	0.000	-0.001	-0.001	0.001	0.001	-0.001	0.001	0.000	0.000	0.000	0.000	0.000	0.000	0.000	0.000	-0.001
2005	1	0.000	0.000	0.000	0.000	0.000	0.000	0.000	0.000	0.000	-0.001	0.001	0.001	0.000	0.000	0.000	0.000	-0.001	0.000	0.000	0.000	0.001
2006	0	0.000	0.000	0.000	0.000	0.000	0.004	0.030	-0.035	0.005	-0.005	0.000	0.000	0.000	0.000	0.001	0.000	0.000	-0.001	0.000	0.000	0.000
2007	0	0.000	0.000	0.000	0.000	-0.002	0.000	0.000	0.002	0.001	0.000	0.000	-0.001	0.000	0.001	0.000	0.000	-0.004	0.002	0.000	0.000	0.000
2008	0	0.000	0.000	0.000	0.000	0.000	0.000	0.000	0.000	0.000	0.000	0.000	0.000	0.000	0.000	0.000	0.000	0.000	0.000	0.000	0.000	0.000
2009	0	0.000	0.000	0.005	-0.011	0.002	0.004	0.015	-0.010	0.002	-0.004	-0.003	0.000	0.000	0.000	0.000	0.000	0.000	0.000	0.000	0.000	0.000
2010	0	0.000	0.000	0.000	0.000	0.000	0.000	0.000	0.000	0.000	0.000	0.000	0.000	0.000	0.000	0.000	0.000	0.000	0.000	0.000	0.000	0.000
2011	-2	0.000	0.000	0.000	0.000	0.000	0.000	0.001	0.001	0.001	0.001	-0.004	0.000	0.000	0.000	0.000	0.000	0.000	0.000	0.000	0.000	0.000
2012	-3	0.000	0.000	0.000	0.001	0.000	-0.002	0.000	0.000	0.000	0.000	0.000	0.000	0.000	0.000	0.000	0.000	0.000	0.000	0.000	0.000	0.000
2013	0	0.000	0.000	0.000	0.000	0.000	0.000	-0.001	0.000	0.000	0.000	-0.001	0.001	0.000	0.000	0.000	0.000	0.000	0.000	0.000	0.000	0.000

**Table 2.13.** Age composition of landed Red Grouper for the commercial longline (reweighted by the length frequency to account for non-representative sampling). Adjusted sample sizes (N adj) were obtained by taking the square root of observed sample sizes (N) and rescaling them during the assessment process using the Francis iterative reweighting approach. Data bars indicate the relative magnitude of the annual age frequency. Red text identifies years which were not included in modeling due to low sample sizes (N < 10).

Year	N	N adj	Age-1	Age-2	Age-3	Age-4	Age-5	Age-6	Age-7	Age-8	Age-9	Age-10	Age-11	Age-12	Age-13	Age-14	Age-15	Age-16	Age-17	Age-18	Age-19	Age-20+	
1991	37	11.3	0.00	0.00	0.00	0.00	0.14	0.13	0.33	0.16	0.12	0.00	0.02	0.01	0.00	0.00	0.00	0.00	0.00	0.00	0.00	0.08	0.00
1992	137	22.5	0.00	0.00	0.00	0.00	0.13	0.19	0.36	0.17	0.09	0.02	0.01	0.02	0.00	0.00	0.00	0.00	0.01	0.00	0.00	0.00	0.00
1993	200	26.3	0.00	0.00	0.01	0.06	0.14	0.30	0.24	0.13	0.05	0.04	0.01	0.00	0.01	0.00	0.00	0.00	0.00	0.00	0.00	0.00	0.00
1994	88	16.9	0.00	0.00	0.00	0.06	0.12	0.14	0.28	0.16	0.10	0.09	0.02	0.02	0.00	0.00	0.00	0.00	0.00	0.00	0.00	0.00	0.00
1995	140	22.5	0.00	0.00	0.00	0.02	0.09	0.33	0.13	0.23	0.11	0.07	0.01	0.00	0.00	0.00	0.00	0.00	0.00	0.00	0.00	0.00	0.01
1996	96	18.8	0.00	0.00	0.00	0.01	0.07	0.23	0.36	0.06	0.18	0.07	0.01	0.00	0.00	0.00	0.00	0.00	0.00	0.00	0.00	0.00	0.00
1997	7	5.6	0.00	0.00	0.45	0.35	0.06	0.00	0.14	0.00	0.00	0.00	0.00	0.00	0.00	0.00	0.00	0.00	0.00	0.00	0.00	0.00	0.00
1998	122	20.6	0.00	0.00	0.00	0.03	0.17	0.17	0.27	0.15	0.10	0.04	0.05	0.01	0.01	0.00	0.00	0.00	0.00	0.00	0.00	0.00	0.00
1999	643	46.9	0.00	0.00	0.00	0.01	0.06	0.11	0.18	0.25	0.20	0.09	0.05	0.02	0.01	0.01	0.00	0.00	0.00	0.00	0.00	0.00	0.00
2000	405	37.5	0.00	0.00	0.00	0.04	0.06	0.20	0.14	0.17	0.12	0.10	0.10	0.03	0.02	0.01	0.00	0.00	0.00	0.00	0.00	0.00	0.00
2001	1,222	65.7	0.00	0.00	0.00	0.00	0.20	0.13	0.24	0.12	0.06	0.09	0.08	0.04	0.01	0.01	0.01	0.00	0.00	0.00	0.00	0.00	0.00
2002	1,067	61.9	0.00	0.00	0.00	0.00	0.05	0.27	0.17	0.16	0.12	0.06	0.06	0.06	0.02	0.01	0.01	0.00	0.00	0.00	0.00	0.00	0.00
2003	1,080	61.9	0.00	0.00	0.00	0.03	0.03	0.11	0.24	0.14	0.14	0.09	0.06	0.05	0.04	0.03	0.01	0.01	0.01	0.00	0.00	0.00	0.00
2004	1,114	61.9	0.00	0.00	0.00	0.01	0.23	0.05	0.15	0.19	0.12	0.08	0.05	0.03	0.02	0.03	0.01	0.01	0.00	0.00	0.00	0.00	0.01
2005	1,456	71.3	0.00	0.00	0.00	0.00	0.10	0.44	0.08	0.12	0.11	0.06	0.03	0.02	0.01	0.01	0.00	0.01	0.00	0.00	0.00	0.00	0.00
2006	538	43.1	0.00	0.00	0.00	0.00	0.03	0.17	0.40	0.15	0.08	0.06	0.04	0.03	0.02	0.01	0.01	0.01	0.00	0.00	0.00	0.00	0.00
2007	596	45.0	0.00	0.00	0.00	0.00	0.06	0.10	0.19	0.30	0.12	0.06	0.07	0.03	0.02	0.03	0.01	0.00	0.00	0.00	0.00	0.00	0.00
2008	509	43.1	0.00	0.00	0.00	0.00	0.02	0.20	0.14	0.24	0.24	0.07	0.05	0.02	0.01	0.01	0.00	0.00	0.00	0.00	0.00	0.00	0.00
2009	993	60.0	0.00	0.00	0.00	0.00	0.02	0.07	0.33	0.12	0.17	0.18	0.04	0.01	0.01	0.01	0.01	0.00	0.00	0.00	0.00	0.00	0.01
2010	650	46.9	0.00	0.00	0.01	0.12	0.06	0.12	0.18	0.28	0.09	0.10	0.03	0.01	0.00	0.00	0.00	0.00	0.00	0.00	0.00	0.00	0.00
2011	499	41.3	0.00	0.00	0.00	0.05	0.31	0.06	0.14	0.12	0.17	0.04	0.06	0.02	0.01	0.00	0.00	0.00	0.00	0.00	0.00	0.00	0.00
2012	861	54.4	0.00	0.00	0.00	0.00	0.11	0.46	0.09	0.08	0.06	0.09	0.04	0.03	0.01	0.00	0.01	0.00	0.00	0.00	0.00	0.00	0.00
2013	1,142	63.8	0.00	0.00	0.00	0.00	0.03	0.26	0.40	0.09	0.06	0.05	0.05	0.02	0.02	0.01	0.00	0.00	0.00	0.00	0.00	0.00	0.00
2014	898	56.3	0.00	0.00	0.00	0.00	0.01	0.07	0.28	0.30	0.13	0.08	0.03	0.03	0.02	0.03	0.01	0.01	0.00	0.00	0.00	0.00	0.00
2015	583	45.0	0.00	0.00	0.00	0.01	0.01	0.04	0.04	0.26	0.23	0.14	0.09	0.04	0.04	0.03	0.02	0.02	0.01	0.00	0.00	0.00	0.01
2016	586	45.0	0.00	0.00	0.00	0.02	0.07	0.13	0.10	0.07	0.19	0.18	0.10	0.05	0.03	0.02	0.01	0.01	0.01	0.01	0.00	0.00	0.00
2017	523	43.1	0.00	0.00	0.01	0.03	0.16	0.13	0.14	0.09	0.09	0.15	0.12	0.03	0.02	0.01	0.01	0.00	0.00	0.00	0.00	0.00	0.00

**Table 2.14.** Difference in commercial longline age composition of Red Grouper and sample size (N) from the previous assessment (SEDAR61 Value – SEDAR42 Value). Larger differences identified by shading (red: SEDAR61 higher, blue: SEDAR61 lower).

Year	N	Age-1	Age-2	Age-3	Age-4	Age-5	Age-6	Age-7	Age-8	Age-9	Age-10	Age-11	Age-12	Age-13	Age-14	Age-15	Age-16	Age-17	Age-18	Age-19	Age-20
1991	0	0.000	0.000	0.000	0.000	0.000	0.000	0.000	0.002	-0.002	0.000	0.000	0.000	0.000	0.000	0.000	0.000	0.000	0.000	0.000	0.000
1992	-6	0.000	0.000	0.000	0.000	-0.012	-0.002	-0.005	0.011	0.005	0.000	0.000	0.002	0.000	0.000	0.000	0.000	0.000	0.000	0.000	0.000
1993	0	0.000	0.000	0.010	0.007	0.008	0.015	-0.014	-0.004	-0.021	0.002	-0.002	0.000	0.000	0.000	0.000	-0.001	0.000	0.000	0.000	0.000
1994	0	0.000	0.000	0.000	0.000	-0.017	0.017	-0.012	0.017	-0.004	-0.003	0.000	0.001	0.001	0.000	0.000	0.000	0.000	0.000	0.000	0.001
1995	0	0.000	0.000	0.000	-0.001	0.011	-0.001	-0.006	-0.004	-0.003	0.007	0.000	-0.001	-0.001	0.000	0.000	0.000	0.000	0.000	0.000	0.000
1996	0	0.000	0.000	0.000	-0.002	-0.010	-0.006	0.020	0.001	-0.002	0.000	0.000	0.000	0.000	0.000	-0.002	0.000	0.000	0.000	0.000	0.000
1997	0	0.000	0.000	0.452	-0.371	-0.022	-0.058	0.000	0.000	0.000	0.000	0.000	0.000	0.000	0.000	0.000	0.000	0.000	0.000	0.000	0.000
1998	0	0.000	0.000	0.000	-0.012	0.016	0.003	-0.007	-0.002	-0.006	0.011	-0.009	-0.002	0.006	0.000	0.000	0.000	0.000	0.000	0.000	0.000
1999	0	0.000	0.000	0.000	0.000	0.000	0.000	0.000	-0.001	0.000	0.000	0.000	0.000	0.000	0.000	0.000	0.000	0.000	0.000	0.000	0.000
2000	0	0.000	0.000	0.000	0.024	0.002	-0.001	-0.009	-0.013	0.004	-0.002	-0.007	-0.009	0.013	0.002	-0.003	-0.002	0.003	0.000	-0.001	-0.001
2001	12	0.000	0.000	0.000	0.002	0.059	-0.003	-0.017	-0.013	-0.005	-0.002	-0.009	-0.006	-0.001	-0.001	-0.001	-0.001	0.000	0.000	0.000	0.000
2002	0	0.000	0.000	0.000	0.001	0.008	0.041	0.004	-0.013	-0.016	-0.006	-0.004	-0.008	-0.002	-0.003	-0.001	0.000	0.000	0.000	0.000	0.001
2003	0	0.000	0.000	0.000	0.002	0.005	0.014	0.013	-0.010	-0.005	-0.007	-0.006	0.000	-0.002	-0.002	-0.001	0.000	-0.001	0.000	0.000	0.001
2004	-39	0.000	0.000	0.000	0.003	0.035	0.001	-0.004	-0.001	-0.010	-0.007	-0.003	-0.006	-0.003	-0.002	-0.002	0.000	-0.001	0.000	-0.001	-0.001
2005	1	0.000	0.000	0.000	-0.001	-0.006	0.035	-0.001	-0.007	-0.004	-0.009	-0.002	0.000	-0.001	-0.001	-0.002	0.000	-0.001	0.000	0.000	-0.001
2006	0	0.000	0.000	0.000	0.001	-0.002	0.009	0.056	-0.018	-0.018	-0.013	-0.003	-0.002	-0.002	-0.004	-0.001	-0.001	0.000	0.000	0.000	0.000
2007	-3	0.000	0.000	0.000	-0.001	0.010	0.008	0.021	0.027	-0.020	-0.003	-0.017	-0.004	-0.006	-0.009	-0.003	-0.001	-0.001	-0.001	0.000	0.000
2008	0	0.000	0.000	0.000	0.000	-0.001	0.021	0.007	-0.019	0.006	0.003	-0.007	-0.004	-0.003	-0.002	-0.001	-0.001	-0.001	-0.001	0.001	0.000
2009	-1	0.000	0.000	0.000	-0.001	0.002	0.008	0.060	-0.021	-0.010	-0.017	-0.010	-0.002	-0.004	-0.004	0.005	-0.002	-0.001	0.000	-0.001	-0.002
2010	0	0.000	0.000	0.000	-0.003	0.001	-0.005	-0.003	0.030	-0.001	-0.013	-0.007	0.001	0.003	-0.001	-0.001	-0.001	0.000	0.000	-0.001	0.000
2011	0	0.000	0.000	0.000	0.000	0.048	-0.004	-0.013	-0.006	-0.007	-0.006	-0.006	-0.002	-0.002	0.000	0.000	-0.001	0.000	0.000	0.000	0.000
2012	0	0.000	0.000	0.000	-0.001	0.000	0.041	-0.007	-0.009	-0.011	-0.003	-0.004	-0.003	-0.001	0.001	-0.002	0.000	0.000	0.000	0.000	0.000
2013	12	0.000	0.000	0.000	0.000	-0.009	-0.024	0.036	0.002	-0.008	0.001	-0.001	0.005	-0.001	-0.001	0.000	0.000	0.000	0.000	0.000	0.000

**Table 2.15.** Age composition of landed Red Grouper for the commercial trap (reweighted by the length frequency to account for non-representative sampling). Adjusted sample sizes (N adj) were obtained by taking the square root of observed sample sizes (N) and rescaling them during the assessment process using the Francis iterative reweighting approach. Data bars indicate the relative magnitude of the annual age frequency. Red text identifies years which were not included in modeling due to low sample sizes (N < 10).

Year	N	N adj	Age-1	Age-2	Age-3	Age-4	Age-5	Age-6	Age-7	Age-8	Age-9	Age-10	Age-11	Age-12	Age-13	Age-14	Age-15	Age-16	Age-17	Age-18	Age-19	Age-20+
1991	2	1.4	0.00	0.00	0.00	0.03	0.00	0.97	0.00	0.00	0.00	0.00	0.00	0.00	0.00	0.00	0.00	0.00	0.00	0.00	0.00	0.00
1992	14	5.6	0.00	0.00	0.00	0.00	0.44	0.20	0.04	0.25	0.00	0.06	0.00	0.01	0.00	0.00	0.00	0.00	0.00	0.00	0.00	0.00
1993	84	12.6	0.00	0.00	0.00	0.04	0.04	0.21	0.35	0.27	0.07	0.01	0.00	0.00	0.00	0.00	0.00	0.00	0.00	0.00	0.00	0.00
1994	29	7.0	0.00	0.00	0.00	0.00	0.00	0.00	0.20	0.14	0.22	0.36	0.07	0.01	0.00	0.01	0.00	0.00	0.00	0.00	0.00	0.00
1995	39	8.4	0.00	0.00	0.00	0.00	0.05	0.48	0.11	0.17	0.12	0.02	0.00	0.06	0.01	0.00	0.00	0.00	0.00	0.00	0.00	0.00
1996	8	4.2	0.00	0.00	0.00	0.00	0.00	0.00	0.36	0.17	0.19	0.21	0.00	0.07	0.00	0.00	0.00	0.00	0.00	0.00	0.00	0.00
1997	17	5.6	0.00	0.00	0.00	0.17	0.38	0.30	0.04	0.10	0.00	0.00	0.00	0.00	0.01	0.00	0.00	0.00	0.00	0.00	0.00	0.00
1998	33	8.4	0.00	0.00	0.02	0.13	0.02	0.15	0.24	0.16	0.17	0.06	0.00	0.04	0.00	0.00	0.00	0.00	0.00	0.00	0.00	0.00
1999	31	8.4	0.00	0.00	0.00	0.10	0.07	0.10	0.03	0.21	0.16	0.11	0.19	0.00	0.02	0.00	0.00	0.00	0.00	0.00	0.00	0.00
2000	38	8.4	0.00	0.00	0.00	0.02	0.02	0.45	0.21	0.09	0.12	0.03	0.02	0.00	0.03	0.00	0.00	0.00	0.00	0.00	0.00	0.00
2001	40	8.4	0.00	0.00	0.00	0.00	0.08	0.10	0.21	0.17	0.07	0.16	0.01	0.18	0.00	0.00	0.01	0.00	0.01	0.00	0.00	0.00
2002	89	12.6	0.00	0.00	0.00	0.06	0.06	0.17	0.17	0.20	0.10	0.07	0.07	0.04	0.05	0.00	0.01	0.01	0.00	0.00	0.00	0.00
2003	65	11.2	0.00	0.00	0.00	0.20	0.01	0.17	0.18	0.16	0.13	0.05	0.02	0.07	0.00	0.00	0.01	0.00	0.00	0.00	0.00	0.00
2004	36	8.4	0.00	0.00	0.00	0.11	0.27	0.06	0.23	0.13	0.01	0.09	0.03	0.00	0.00	0.02	0.00	0.01	0.00	0.03	0.00	0.00
2006	173	18.2	0.00	0.00	0.00	0.00	0.01	0.09	0.54	0.15	0.05	0.06	0.03	0.04	0.01	0.00	0.01	0.00	0.01	0.00	0.00	0.00

**Table 2.16.** Difference in commercial trap age composition of Red Grouper and sample size (N) from the previous assessment (SEDAR61 Value – SEDAR42 Value). Larger differences identified by shading (red: SEDAR61 higher, blue: SEDAR61 lower).

Year	N	Age-1	Age-2	Age-3	Age-4	Age-5	Age-6	Age-7	Age-8	Age-9	Age-10	Age-11	Age-12	Age-13	Age-14	Age-15	Age-16	Age-17	Age-18	Age-19	Age-20	
1991	0	0.000	0.000	0.000	0.002	0.000	-0.002	0.000	0.000	0.000	0.000	0.000	0.000	0.000	0.000	0.000	0.000	0.000	0.000	0.000	0.000	0.000
1992	0	0.000	0.000	0.000	0.000	0.294	-0.294	0.000	0.000	0.000	0.000	0.000	0.000	0.000	0.000	0.000	0.000	0.000	0.000	0.000	0.000	0.000
1993	0	0.000	0.000	0.000	-0.006	-0.002	-0.002	0.014	-0.002	-0.002	0.000	0.000	0.000	0.000	0.000	0.000	0.000	0.000	0.000	0.000	0.000	0.000
1994	0	0.000	0.000	0.000	0.000	0.000	-0.028	0.075	-0.209	-0.100	0.238	0.024	0.000	0.000	0.000	0.000	0.000	0.000	0.000	0.000	0.000	0.000
1995	0	0.000	0.000	0.000	0.000	0.000	0.017	0.000	-0.050	0.033	0.000	0.000	0.000	0.000	0.000	0.000	0.000	0.000	0.000	0.000	0.000	0.000
1996	0	0.000	0.000	0.000	0.000	0.000	0.000	0.013	0.001	0.006	-0.023	0.000	0.002	0.000	0.000	0.000	0.000	0.000	0.000	0.000	0.000	0.000
1997	0	0.000	0.000	0.000	0.041	-0.041	0.000	0.000	0.000	0.000	0.000	0.000	0.000	0.000	0.000	0.000	0.000	0.000	0.000	0.000	0.000	0.000
1998	0	0.000	0.000	-0.005	0.032	-0.005	-0.002	-0.017	0.003	-0.005	0.000	0.000	0.000	0.000	0.000	0.000	0.000	0.000	0.000	0.000	0.000	0.000
1999	0	0.000	0.000	0.000	0.000	0.000	0.000	0.000	0.000	0.000	0.000	0.000	0.000	0.000	0.000	0.000	0.000	0.000	0.000	0.000	0.000	0.000
2000	0	0.000	0.000	0.000	0.000	0.000	0.000	0.000	0.000	0.000	0.000	0.000	0.000	0.000	0.000	0.000	0.000	0.000	0.000	0.000	0.000	0.000
2001	1	0.000	0.000	0.000	0.000	0.000	0.000	0.000	-0.006	0.000	0.011	0.000	0.000	0.000	0.000	-0.006	0.000	0.000	0.000	0.000	0.000	0.000
2002	0	0.000	0.000	0.000	0.000	0.000	0.000	0.000	0.000	0.000	0.000	0.000	0.000	0.000	0.000	0.000	0.000	0.000	0.000	0.000	0.000	0.000
2003	0	0.000	0.000	0.000	0.000	0.000	0.000	0.000	0.000	0.000	0.000	0.000	0.000	0.000	0.000	0.000	0.000	0.000	0.000	0.000	0.000	0.000
2004	-2	0.000	0.000	0.000	0.002	0.005	0.001	-0.007	-0.017	0.000	0.013	0.001	0.000	0.000	0.000	0.000	0.000	0.000	0.001	0.000	0.000	0.000
2006	0	0.000	0.000	0.000	0.000	0.000	0.000	0.000	0.000	0.000	0.000	0.000	0.000	0.000	0.000	0.000	0.000	0.000	0.000	0.000	0.000	0.000

**Table 2.17.** Comparison of trip-level effort variables for vertical line gear between observer and logbook data; N is the number of matched observer-logbook trips; mean difference (observer value – logbook value) for each metric was evaluated with a paired t-test.

<b>Effort Variable</b>	<b>N</b>	<b>Mean Difference</b>	<b>SE Difference</b>	<b>p-value</b>
Set Time (hours)	916	-16.21	0.74	<0.0001
Fishing Day (hours)	916	0.11	0.73	0.8831
Average Lines per Set	916	-0.310	0.039	<0.0001
Max Lines per Set	916	0.356	0.046	<0.0001
Average Hooks per Line 1 (gear configurations)	916	-0.95	0.17	<0.0001
Average Hooks per Line 2 (sampled lines/sets)	916	-0.36	0.16	0.0226

**Table 2.18.** Comparison of trip-level effort variables for bottom longline gear between observer and logbook data; N is the number of matched observer-logbook trips; mean difference (observer value – logbook value) for each metric was evaluated with a paired t-test.

<b>Effort Variable</b>	<b>N</b>	<b>Mean Difference</b>	<b>SE Difference</b>	<b>p-value</b>
Number of Sets	375	-0.54	0.38	0.1576
Average Hooks per Set	368	293.83	22.53	<0.0001
Average Soak Hours per Set 1 (first hook in, last hook out)	355	2.33	0.08	<0.0001
Average Soak Hours per Set 2 (last hook in, last hook out)	301	1.23	0.08	<0.0001
Average Soak Hours per Set 3 (last hook in, first hook out)	301	-0.29	0.29	0.3185
Average Soak Hours per Set 4 (first hook in, first hook out)	303	0.68	0.29	0.0202



**Table 2.19.** Commercial vertical line and longline discards (number of Red Grouper) using the SEDAR61 recommended approach.

Year	Vertical Line	Longline
1993	79,662	514,033
1994	94,368	668,159
1995	49,123	302,219
1996	112,944	667,938
1997	132,132	878,497
1998	127,683	718,051
1999	140,955	754,469
2000	142,683	633,778
2001	146,668	652,257
2002	151,052	579,902
2003	158,908	596,105
2004	151,788	567,853
2005	133,793	440,858
2006	146,203	506,568
2007	150,881	405,702
2008	127,661	480,530
2009	219,006	153,431
2010	198,729	177,525
2011	290,423	346,979
2012	178,703	402,936
2013	96,399	209,867
2014	59,449	324,659
2015	86,568	195,727
2016	96,899	242,272
2017	71,658	216,046

**Table 2.20.** Size composition (2 cm length bins) of the commercial vertical line discards for Red Grouper. Adjusted sample sizes (N adj) were obtained by taking the square root of observed sample sizes (N) and rescaling them during the assessment process using the Francis iterative reweighting approach. Data bars indicate the relative magnitude of the annual length frequency.

Year	N	N adj	2	4	6	8	10	12	14	16	18	20	22	24	26	28	30	32	34	36	38	40	42	44	46	48
2006	1,021	28.7	0.00	0.00	0.00	0.00	0.00	0.00	0.00	0.00	0.00	0.00	0.00	0.00	0.00	0.00	0.01	0.02	0.04	0.09	0.11	0.16	0.17	0.14	0.15	0.09
2007	2,105	41.2	0.00	0.00	0.00	0.00	0.00	0.00	0.00	0.00	0.00	0.00	0.00	0.00	0.00	0.00	0.00	0.01	0.01	0.03	0.05	0.11	0.18	0.19	0.20	0.16
2008	1,085	29.6	0.00	0.00	0.00	0.00	0.00	0.00	0.00	0.00	0.00	0.00	0.00	0.00	0.00	0.01	0.02	0.04	0.07	0.05	0.08	0.08	0.13	0.17	0.22	0.13
2009	1,544	34.9	0.00	0.00	0.00	0.00	0.00	0.00	0.00	0.00	0.00	0.00	0.00	0.00	0.00	0.01	0.03	0.08	0.17	0.19	0.18	0.16	0.09	0.04	0.02	0.01
2010	3,049	49.3	0.00	0.00	0.00	0.00	0.00	0.00	0.00	0.00	0.00	0.00	0.00	0.00	0.00	0.01	0.01	0.02	0.07	0.15	0.19	0.24	0.23	0.07	0.01	0.00
2011	5,320	65.4	0.00	0.00	0.00	0.00	0.00	0.00	0.00	0.00	0.00	0.00	0.00	0.00	0.00	0.00	0.01	0.01	0.04	0.10	0.16	0.22	0.24	0.18	0.04	0.01
2012	9,035	85.1	0.00	0.00	0.00	0.00	0.00	0.00	0.00	0.00	0.00	0.00	0.00	0.00	0.00	0.00	0.01	0.02	0.04	0.08	0.14	0.20	0.25	0.16	0.06	0.03
2013	2,311	43.0	0.00	0.00	0.00	0.00	0.00	0.00	0.00	0.00	0.00	0.00	0.00	0.00	0.00	0.00	0.01	0.03	0.05	0.10	0.13	0.22	0.24	0.14	0.05	0.02
2014	1,157	30.5	0.00	0.00	0.00	0.00	0.00	0.00	0.00	0.00	0.00	0.00	0.00	0.00	0.01	0.01	0.02	0.03	0.06	0.08	0.15	0.20	0.26	0.14	0.03	0.00
2015	3,488	52.9	0.00	0.00	0.00	0.00	0.00	0.00	0.00	0.00	0.00	0.00	0.00	0.00	0.00	0.01	0.02	0.05	0.09	0.12	0.15	0.18	0.19	0.14	0.05	0.01
2016	2,437	43.9	0.00	0.00	0.00	0.00	0.00	0.00	0.00	0.00	0.00	0.00	0.00	0.01	0.03	0.03	0.06	0.07	0.09	0.10	0.15	0.18	0.17	0.08	0.01	0.00
2017	909	26.9	0.00	0.00	0.00	0.00	0.00	0.00	0.00	0.00	0.00	0.00	0.00	0.01	0.01	0.03	0.09	0.14	0.13	0.15	0.11	0.12	0.13	0.07	0.00	0.00
Year	N	N adj	50	52	54	56	58	60	62	64	66	68	70	72	74	76	78	80	82	84	86	88	90	92	94	96
2006	1,021	28.7	0.01	0.00	0.00	0.00	0.00	0.00	0.00	0.00	0.00	0.00	0.00	0.00	0.00	0.00	0.00	0.00	0.00	0.00	0.00	0.00	0.00	0.00	0.00	0.00
2007	2,105	41.2	0.04	0.00	0.00	0.00	0.00	0.00	0.00	0.00	0.00	0.00	0.00	0.00	0.00	0.00	0.00	0.00	0.00	0.00	0.00	0.00	0.00	0.00	0.00	0.00
2008	1,085	29.6	0.00	0.00	0.00	0.00	0.00	0.00	0.00	0.00	0.00	0.00	0.00	0.00	0.00	0.00	0.00	0.00	0.00	0.00	0.00	0.00	0.00	0.00	0.00	0.00
2009	1,544	34.9	0.00	0.00	0.01	0.00	0.00	0.00	0.00	0.00	0.00	0.00	0.00	0.00	0.00	0.00	0.00	0.00	0.00	0.00	0.00	0.00	0.00	0.00	0.00	0.00
2010	3,049	49.3	0.00	0.00	0.00	0.00	0.00	0.00	0.00	0.00	0.00	0.00	0.00	0.00	0.00	0.00	0.00	0.00	0.00	0.00	0.00	0.00	0.00	0.00	0.00	0.00
2011	5,320	65.4	0.00	0.00	0.00	0.00	0.00	0.00	0.00	0.00	0.00	0.00	0.00	0.00	0.00	0.00	0.00	0.00	0.00	0.00	0.00	0.00	0.00	0.00	0.00	0.00
2012	9,035	85.1	0.01	0.00	0.00	0.00	0.00	0.00	0.00	0.00	0.00	0.00	0.00	0.00	0.00	0.00	0.00	0.00	0.00	0.00	0.00	0.00	0.00	0.00	0.00	0.00
2013	2,311	43.0	0.00	0.00	0.00	0.00	0.00	0.00	0.00	0.00	0.00	0.00	0.00	0.00	0.00	0.00	0.00	0.00	0.00	0.00	0.00	0.00	0.00	0.00	0.00	0.00
2014	1,157	30.5	0.00	0.00	0.00	0.00	0.00	0.00	0.00	0.00	0.00	0.00	0.00	0.00	0.00	0.00	0.00	0.00	0.00	0.00	0.00	0.00	0.00	0.00	0.00	0.00
2015	3,488	52.9	0.00	0.00	0.00	0.00	0.00	0.00	0.00	0.00	0.00	0.00	0.00	0.00	0.00	0.00	0.00	0.00	0.00	0.00	0.00	0.00	0.00	0.00	0.00	0.00
2016	2,437	43.9	0.00	0.00	0.00	0.00	0.00	0.00	0.00	0.00	0.00	0.00	0.00	0.00	0.00	0.00	0.00	0.00	0.00	0.00	0.00	0.00	0.00	0.00	0.00	0.00
2017	909	26.9	0.00	0.00	0.00	0.00	0.00	0.00	0.00	0.00	0.00	0.00	0.00	0.00	0.00	0.00	0.00	0.00	0.00	0.00	0.00	0.00	0.00	0.00	0.00	0.00

**Table 2.21.** Difference in commercial vertical line discard length composition (2 cm length bins) of Red Grouper and sample size (N) from the previous assessment (SEDAR61 Value – SEDAR42 Value). Larger differences identified by shading (red: SEDAR61 higher, blue: SEDAR61 lower).

Year	N	2	4	6	8	10	12	14	16	18	20	22	24	26	28	30	32
2006	84	0.000	0.000	0.000	0.000	0.000	0.000	0.000	0.000	0.000	0.000	0.000	0.000	0.000	0.000	-0.001	-0.002
2007	41	0.000	0.000	0.000	0.000	0.000	0.000	0.000	0.000	0.000	0.000	0.000	-0.001	0.000	0.000	0.000	0.000
2008	12	0.000	0.000	0.000	0.000	0.000	0.000	0.000	0.000	0.000	0.000	0.000	0.000	0.000	-0.001	0.000	0.000
2009	15	0.000	0.000	0.000	0.000	0.000	0.000	0.000	0.000	0.000	0.000	0.000	0.000	0.000	0.001	0.000	-0.001
2010	69	0.000	0.000	0.000	0.000	0.000	0.000	0.000	0.000	0.000	0.000	0.000	0.000	0.000	0.000	0.000	-0.001
2011	130	0.000	0.000	0.000	0.000	0.000	0.000	0.000	0.000	0.000	0.000	0.000	0.000	0.000	0.000	0.000	0.000
2012	118	0.000	0.000	0.000	0.000	0.000	0.000	0.000	0.000	0.000	0.000	0.000	0.000	0.000	0.000	0.000	0.000
2013	20	0.000	0.000	0.000	0.000	0.000	0.000	0.000	0.000	0.000	0.000	0.000	0.000	0.000	0.000	0.000	0.000
Year	N	34	36	38	40	42	44	46	48	50	52	54	56	58	60	62	64
2006	84	-0.002	0.004	0.000	-0.002	0.004	0.002	0.001	-0.006	0.001	0.000	0.000	0.000	0.000	0.000	0.000	0.000
2007	41	0.000	-0.001	-0.001	0.000	0.000	0.000	0.001	0.001	0.001	0.000	0.000	0.000	0.000	0.000	0.000	0.000
2008	12	0.001	0.001	-0.001	0.000	-0.003	0.001	0.002	-0.001	0.000	0.000	0.000	0.000	0.000	0.000	0.000	0.000
2009	15	-0.001	-0.001	0.002	0.000	0.000	0.000	0.000	0.000	0.000	0.000	0.000	0.000	0.000	0.000	0.000	0.000
2010	69	-0.001	-0.001	-0.003	0.002	0.002	0.002	0.000	0.000	0.000	0.000	0.000	0.000	0.000	0.000	0.000	0.000
2011	130	0.000	-0.001	0.000	-0.002	0.004	-0.002	0.001	0.000	0.000	0.000	0.000	0.000	0.000	0.000	0.000	0.000
2012	118	0.000	-0.001	0.000	0.001	0.000	0.000	0.000	0.000	0.000	0.000	0.000	0.000	0.000	0.000	0.000	0.000
2013	20	0.000	0.000	-0.001	0.000	0.002	0.000	0.000	0.000	0.000	0.000	0.000	0.000	0.000	0.000	0.000	0.000
Year	N	66	68	70	72	74	76	78	80	82	84	86	88	90	92	94	96
2006	84	0.000	0.000	0.000	0.000	0.000	0.000	0.000	0.000	0.000	0.000	0.000	0.000	0.000	0.000	0.000	0.000
2007	41	0.000	0.000	0.000	0.000	0.000	0.000	0.000	0.000	0.000	0.000	0.000	0.000	0.000	0.000	0.000	0.000
2008	12	0.000	0.000	0.000	0.000	0.000	0.000	0.000	0.000	0.000	0.000	0.000	0.000	0.000	0.000	0.000	0.000
2009	15	0.000	0.000	0.000	0.000	0.000	0.000	0.000	0.000	0.000	0.000	0.000	0.000	0.000	0.000	0.000	0.000
2010	69	0.000	0.000	0.000	0.000	0.000	0.000	0.000	0.000	0.000	0.000	0.000	0.000	0.000	0.000	0.000	0.000
2011	130	0.000	0.000	0.000	0.000	0.000	0.000	0.000	0.000	0.000	0.000	0.000	0.000	0.000	0.000	0.000	0.000
2012	118	0.000	0.000	0.000	0.000	0.000	0.000	0.000	0.000	0.000	0.000	0.000	0.000	0.000	0.000	0.000	0.000
2013	20	0.000	0.000	0.000	0.000	0.000	0.000	0.000	0.000	0.000	0.000	0.000	0.000	0.000	0.000	0.000	0.000

**Table 2.22.** Size composition (2 cm length bins) of the commercial longline discards for Red Grouper. Adjusted sample sizes (N adj) were obtained by taking the square root of observed sample sizes (N) and rescaling them during the assessment process using the Francis iterative reweighting approach. Data bars indicate the relative magnitude of the annual length frequency.

Year	N	N adj	2	4	6	8	10	12	14	16	18	20	22	24	26	28	30	32	34	36	38	40	42	44	46	48
2006	4,035	17.9	0.00	0.00	0.00	0.00	0.00	0.00	0.00	0.00	0.00	0.00	0.00	0.00	0.00	0.00	0.00	0.01	0.03	0.06	0.11	0.15	0.17	0.15	0.14	0.12
2007	3,076	15.4	0.00	0.00	0.00	0.00	0.00	0.00	0.00	0.00	0.00	0.00	0.00	0.00	0.00	0.00	0.01	0.01	0.03	0.04	0.07	0.13	0.16	0.20	0.22	0.11
2008	984	8.7	0.00	0.00	0.00	0.00	0.00	0.00	0.00	0.00	0.00	0.00	0.00	0.00	0.01	0.02	0.05	0.04	0.07	0.07	0.12	0.16	0.18	0.20	0.07	0.01
2009	6,908	23.3	0.00	0.00	0.00	0.00	0.00	0.00	0.00	0.00	0.00	0.00	0.00	0.00	0.00	0.01	0.03	0.06	0.08	0.10	0.10	0.10	0.13	0.15	0.14	0.06
2010	19,302	38.9	0.00	0.00	0.00	0.00	0.00	0.00	0.00	0.00	0.00	0.00	0.00	0.00	0.00	0.01	0.02	0.06	0.11	0.15	0.18	0.19	0.16	0.09	0.02	0.00
2011	42,380	57.7	0.00	0.00	0.00	0.00	0.00	0.00	0.00	0.00	0.00	0.00	0.00	0.00	0.00	0.00	0.01	0.03	0.07	0.11	0.15	0.19	0.20	0.14	0.06	0.02
2012	12,761	31.7	0.00	0.00	0.00	0.00	0.00	0.00	0.00	0.00	0.00	0.00	0.00	0.00	0.00	0.00	0.00	0.01	0.03	0.09	0.16	0.21	0.21	0.15	0.07	0.04
2013	23,749	43.2	0.00	0.00	0.00	0.00	0.00	0.00	0.00	0.00	0.00	0.00	0.00	0.00	0.00	0.00	0.01	0.02	0.03	0.06	0.11	0.18	0.24	0.21	0.10	0.03
2014	11,950	30.5	0.00	0.00	0.00	0.00	0.00	0.00	0.00	0.00	0.00	0.00	0.00	0.00	0.00	0.00	0.01	0.02	0.04	0.07	0.11	0.16	0.22	0.23	0.10	0.02
2015	6,168	22.1	0.00	0.00	0.00	0.00	0.00	0.00	0.00	0.00	0.00	0.00	0.00	0.00	0.00	0.01	0.02	0.03	0.07	0.09	0.13	0.18	0.23	0.18	0.06	0.01
2016	15,027	34.5	0.00	0.00	0.00	0.00	0.00	0.00	0.00	0.00	0.00	0.00	0.00	0.00	0.01	0.01	0.03	0.05	0.08	0.12	0.16	0.19	0.19	0.12	0.03	0.00
2017	3,455	16.5	0.00	0.00	0.00	0.00	0.00	0.00	0.00	0.00	0.00	0.00	0.00	0.00	0.00	0.02	0.05	0.08	0.12	0.15	0.16	0.16	0.14	0.09	0.01	0.00
Year	N	N adj	50	52	54	56	58	60	62	64	66	68	70	72	74	76	78	80	82	84	86	88	90	92	94	96
2006	4,035	17.9	0.05	0.00	0.00	0.00	0.00	0.00	0.00	0.00	0.00	0.00	0.00	0.00	0.00	0.00	0.00	0.00	0.00	0.00	0.00	0.00	0.00	0.00	0.00	0.00
2007	3,076	15.4	0.01	0.00	0.00	0.00	0.00	0.00	0.00	0.00	0.00	0.00	0.00	0.00	0.00	0.00	0.00	0.00	0.00	0.00	0.00	0.00	0.00	0.00	0.00	0.00
2008	984	8.7	0.00	0.00	0.00	0.00	0.00	0.00	0.00	0.00	0.00	0.00	0.00	0.00	0.00	0.00	0.00	0.00	0.00	0.00	0.00	0.00	0.00	0.00	0.00	0.00
2009	6,908	23.3	0.01	0.00	0.00	0.00	0.00	0.00	0.00	0.00	0.00	0.00	0.00	0.00	0.00	0.00	0.00	0.00	0.00	0.00	0.00	0.00	0.00	0.00	0.00	0.00
2010	19,302	38.9	0.00	0.00	0.00	0.00	0.00	0.00	0.00	0.00	0.00	0.00	0.00	0.00	0.00	0.00	0.00	0.00	0.00	0.00	0.00	0.00	0.00	0.00	0.00	0.00
2011	42,380	57.7	0.01	0.00	0.00	0.00	0.00	0.00	0.00	0.00	0.00	0.00	0.00	0.00	0.00	0.00	0.00	0.00	0.00	0.00	0.00	0.00	0.00	0.00	0.00	0.00
2012	12,761	31.7	0.01	0.01	0.00	0.00	0.00	0.00	0.00	0.00	0.00	0.00	0.00	0.00	0.00	0.00	0.00	0.00	0.00	0.00	0.00	0.00	0.00	0.00	0.00	0.00
2013	23,749	43.2	0.00	0.00	0.00	0.00	0.00	0.00	0.00	0.00	0.00	0.00	0.00	0.00	0.00	0.00	0.00	0.00	0.00	0.00	0.00	0.00	0.00	0.00	0.00	0.00
2014	11,950	30.5	0.00	0.00	0.00	0.00	0.00	0.00	0.00	0.00	0.00	0.00	0.00	0.00	0.00	0.00	0.00	0.00	0.00	0.00	0.00	0.00	0.00	0.00	0.00	0.00
2015	6,168	22.1	0.00	0.00	0.00	0.00	0.00	0.00	0.00	0.00	0.00	0.00	0.00	0.00	0.00	0.00	0.00	0.00	0.00	0.00	0.00	0.00	0.00	0.00	0.00	0.00
2016	15,027	34.5	0.00	0.00	0.00	0.00	0.00	0.00	0.00	0.00	0.00	0.00	0.00	0.00	0.00	0.00	0.00	0.00	0.00	0.00	0.00	0.00	0.00	0.00	0.00	0.00
2017	3,455	16.5	0.00	0.00	0.00	0.00	0.00	0.00	0.00	0.00	0.00	0.00	0.00	0.00	0.00	0.00	0.00	0.00	0.00	0.00	0.00	0.00	0.00	0.00	0.00	0.00

**Table 2.23.** Difference in commercial longline discard length composition (2 cm length bins) of Red Grouper and sample size (N) from the previous assessment (SEDAR61 Value – SEDAR42 Value). Larger differences identified by shading (red: SEDAR61 higher, blue: SEDAR61 lower).

Year	N	2	4	6	8	10	12	14	16	18	20	22	24	26	28	30	32	
2006	123	0.000	0.000	0.000	0.000	0.000	0.000	0.000	0.000	0.000	0.000	0.000	0.000	0.000	0.000	-0.001	-0.001	
2007	155	0.000	0.000	0.000	0.000	0.000	0.000	0.000	0.000	0.000	0.000	0.000	0.000	0.000	0.000	0.000	0.000	
2008	67	0.000	0.000	0.000	0.000	0.000	0.000	0.000	0.000	0.000	0.000	0.000	0.000	0.000	0.000	-0.001	-0.003	-0.002
2009	461	0.000	0.000	0.000	0.000	0.000	0.000	0.000	0.000	0.000	0.000	0.000	0.000	0.000	0.000	0.000	-0.001	-0.003
2010	667	0.000	0.000	0.000	0.000	0.000	0.000	0.000	0.000	0.000	0.000	0.000	0.000	0.000	0.000	0.000	0.000	-0.001
2011	2,141	0.000	0.000	0.000	0.000	0.000	0.000	0.000	0.000	0.000	0.000	0.000	0.000	0.000	0.000	0.000	0.000	-0.001
2012	792	0.000	0.000	0.000	0.000	0.000	0.000	0.000	0.000	0.000	0.000	0.000	0.000	0.000	0.000	0.000	0.000	-0.001
2013	1,693	0.000	0.000	0.000	0.000	0.000	0.000	0.000	0.000	0.000	0.000	0.000	0.000	0.000	0.000	0.000	0.000	-0.001
Year	N	34	36	38	40	42	44	46	48	50	52	54	56	58	60	62	64	
2006	123	-0.003	-0.003	0.002	0.006	0.008	0.005	0.001	-0.001	-0.002	-0.003	-0.002	-0.002	-0.001	-0.001	-0.001	0.000	
2007	155	-0.001	0.000	0.000	-0.001	0.002	0.003	0.003	-0.004	0.000	0.000	0.000	0.000	0.000	0.000	0.000	0.000	
2008	67	-0.003	-0.002	0.002	0.005	0.003	0.003	-0.001	-0.001	0.000	0.000	0.000	0.000	0.000	0.000	0.000	0.000	
2009	461	-0.003	0.000	-0.004	-0.002	-0.001	0.010	0.007	-0.002	0.000	0.000	0.000	0.000	0.000	0.000	0.000	0.000	
2010	667	0.000	0.001	0.001	0.001	0.000	-0.001	-0.001	0.000	0.000	0.000	0.000	0.000	0.000	0.000	0.000	0.000	
2011	2,141	-0.001	0.000	0.000	0.002	0.002	-0.001	0.000	0.000	0.000	0.000	0.000	0.000	0.000	0.000	0.000	0.000	
2012	792	-0.001	-0.002	0.002	0.002	0.004	-0.001	0.000	-0.001	-0.001	0.000	0.000	0.000	0.000	0.000	0.000	0.000	
2013	1,693	-0.002	-0.001	-0.002	-0.001	0.004	0.004	0.000	0.000	0.000	0.000	0.000	0.000	0.000	0.000	0.000	0.000	
Year	N	66	68	70	72	74	76	78	80	82	84	86	88	90	92	94	96	
2006	123	0.000	-0.001	0.000	0.000	0.000	0.000	0.000	0.000	0.000	0.000	0.000	0.000	0.000	0.000	0.000	0.000	
2007	155	0.000	0.000	0.000	0.000	0.000	0.000	0.000	0.000	0.000	0.000	0.000	0.000	0.000	0.000	0.000	0.000	
2008	67	0.000	0.000	0.000	0.000	0.000	0.000	0.000	0.000	0.000	0.000	0.000	0.000	0.000	0.000	0.000	0.000	
2009	461	0.000	0.000	0.000	0.000	0.000	0.000	0.000	0.000	0.000	0.000	0.000	0.000	0.000	0.000	0.000	0.000	
2010	667	0.000	0.000	0.000	0.000	0.000	0.000	0.000	0.000	0.000	0.000	0.000	0.000	0.000	0.000	0.000	0.000	
2011	2,141	0.000	0.000	0.000	0.000	0.000	0.000	0.000	0.000	0.000	0.000	0.000	0.000	0.000	0.000	0.000	0.000	
2012	792	0.000	0.000	0.000	0.000	0.000	0.000	0.000	0.000	0.000	0.000	0.000	0.000	0.000	0.000	0.000	0.000	
2013	1,693	0.000	0.000	0.000	0.000	0.000	0.000	0.000	0.000	0.000	0.000	0.000	0.000	0.000	0.000	0.000	0.000	

**Table 2.24.** Fishery-dependent standardized CPUE indices and associated coefficients of variation for Red Grouper derived from commercial logbook data during the pre-Individual Fishing Quota period. All indices are scaled to a mean of one over each respective time series. The standard errors used in the SEDAR61 Assessment Model were scaled to a common mean of 0.3 (to provide equal weighting of all indices in the assessment model).

Year	Commercial Vertical line		Commercial Longline	
	Index	CV	Index	CV
1993	0.731	0.311	0.979	0.332
1994	0.716	0.307	0.724	0.294
1995	0.789	0.311	0.774	0.305
1996	0.491	0.320	1.040	0.319
1997	0.565	0.321	0.907	0.266
1998	0.519	0.320	0.955	0.274
1999	0.740	0.313	0.997	0.272
2000	0.991	0.305	0.898	0.289
2001	1.347	0.297	1.056	0.278
2002	1.387	0.296	1.060	0.292
2003	0.947	0.292	0.928	0.281
2004	1.274	0.287	1.112	0.273
2005	1.417	0.289	1.444	0.283
2006	1.143	0.292	1.093	0.270
2007	1.207	0.289	0.780	0.312
2008	1.531	0.288	1.181	0.308
2009	1.206	0.287	1.073	0.453

**Table 2.25.** Recreational landings (number of Red Grouper) provided for SEDAR61 and SEDAR42 by fishing mode, along with the ratio. Colors indicate the relative change in the landings, with blue (< 1) indicative of lower SEDAR61 landings, white indicative of values = 1.0 (identical landings), and red (> 1) indicative of higher SEDAR61 landings.

Year	SEDAR61			SEDAR42			Ratio (SEDAR61/SEDAR42)		
	Charter	Headboat	Private	Charter	Headboat	Private	Charter	Headboat	Private
1981	286,302	179,064	386,443	44,565	24,813	77,072	6.4	7.2	5.0
1982	68,883	43,082	592,060	9,413	5,241	163,825	7.3	8.2	3.6
1983	54,775	34,259	1,158,535	27,335	15,219	351,074	2.0	2.3	3.3
1984	341,951	213,869	261,162	75,279	41,913	118,114	4.5	5.1	2.2
1985	473,087	295,886	633,586	107,215	59,694	418,989	4.4	5.0	1.5
1986	140,113	32,913	1,075,513	79,799	32,913	525,519	1.8	1.0	2.0
1987	68,762	25,729	753,219	38,279	25,729	298,229	1.8	1.0	2.5
1988	57,239	27,954	1,532,243	51,948	27,954	687,306	1.1	1.0	2.2
1989	41,473	49,777	2,260,505	38,012	49,777	713,005	1.1	1.0	3.2
1990	90,888	14,582	459,845	50,212	14,582	130,122	1.8	1.0	3.5
1991	45,056	9,509	540,976	11,401	9,509	284,585	4.0	1.0	1.9
1992	64,256	9,049	857,064	52,191	9,049	419,526	1.2	1.0	2.0
1993	22,154	8,802	646,745	27,501	8,802	331,594	0.8	1.0	2.0
1994	38,510	9,617	526,039	32,000	9,617	279,441	1.2	1.0	1.9
1995	73,577	14,499	465,742	59,008	14,499	226,726	1.2	1.0	2.1
1996	25,124	15,594	106,962	22,673	15,594	87,205	1.1	1.0	1.2
1997	17,491	4,676	154,920	22,229	4,676	55,004	0.8	1.0	2.8
1998	24,350	4,382	183,081	25,665	4,382	83,245	0.9	1.0	2.2
1999	33,082	6,918	451,658	34,514	6,918	160,692	1.0	1.0	2.8
2000	97,146	8,861	506,850	126,774	8,861	240,164	0.8	1.0	2.1
2001	47,671	5,560	313,807	63,966	5,560	173,124	0.7	1.0	1.8
2002	36,215	4,402	410,559	49,186	4,402	218,694	0.7	1.0	1.9
2003	43,304	7,521	306,090	53,850	7,521	164,178	0.8	1.0	1.9
2004	86,977	13,810	1,133,056	91,840	13,810	438,051	0.9	1.0	2.6
2005	86,281	13,967	385,348	86,712	13,967	96,952	1.0	1.0	4.0
2006	40,257	4,630	332,549	37,001	4,630	94,509	1.1	1.0	3.5
2007	21,344	4,245	291,200	26,289	4,245	128,452	0.8	1.0	2.3
2008	44,789	5,003	208,239	41,527	5,003	91,601	1.1	1.0	2.3
2009	25,682	4,666	179,485	28,960	4,666	95,599	0.9	1.0	1.9
2010	50,596	4,952	282,634	55,165	4,952	100,922	0.9	1.0	2.8
2011	45,102	7,387	230,444	48,798	7,387	62,111	0.9	1.0	3.7
2012	94,780	13,544	588,211	91,304	13,544	208,979	1.0	1.0	2.8
2013	139,583	14,088	719,170	139,184	14,089	301,203	1.0	1.0	2.4
2014	101,679	8,123	760,332	-	-	-	-	-	-
2015	75,712	5,972	461,312	-	-	-	-	-	-
2016	66,545	5,704	335,367	-	-	-	-	-	-
2017	49,353	2,709	196,137	-	-	-	-	-	-

**Table 2.26.** Number of Red Grouper length samples collected between 1981 and 2017 from the recreational fishery in the Gulf of Mexico by data source: GulfFIN – Gulf States Marine Fisheries Commission Fisheries Information Network; FIN-OBS – Fishery Information Network Headboat Observer; FWRI-OBS – FWRI At-Sea Observer; GRFS – Florida Fish and Wildlife Conservation Commission Gulf Reef Fish Survey; RECFIN – Recreational Fisheries Information Network; MRIP – Marine Recreational Information Program; SRHS – Southeast Region Headboat Survey; and TIP – Trip Interview Program.

Year	GulfFIN			RECFIN	MRIP	SRHS	TIP	Total
	FIN-OBS	FWRI-OBS	GRFS					
1981					130			130
1982					150			150
1983					161			161
1984					218		19	237
1985					221			221
1986					535	370		905
1987					332	546		878
1988					562	353		915
1989					381	699		1,080
1990					106	240		346
1991					151	103	46	300
1992					512	54	30	596
1993					285	33	64	382
1994					361	52	83	496
1995					325	57	3	385
1996					140	71	100	311
1997					122	47	91	260
1998					281	40	92	413
1999					603	108	25	736
2000					774	69	2	845
2001					699	52	9	760
2002				111	934	135	22	1,202
2003				118	1,172	219	15	1,524
2004				103	2,510	173	11	2,797
2005	18			71	1,841	72	9	2,011
2006				36	757	79	9	881
2007	1			32	540	94	64	731
2008				98	416	89	24	627
2009		121		99	304	50	16	590
2010		169		220	330	52	7	778
2011		195		355	571	93	2	1,216
2012		263		145	1,017	151	16	1,592
2013		174		195	1,151	155		1,675
2014		75		112	1,586	114		1,887
2015		266	180	47	1,186	65		1,744
2016		315	167	48	902	49		1,481
2017		192	138	5	459	21		815
Total	19	1,770	485	1,795	22,725	4,505	759	32,058



**Table 2.27.** Total number and percentage of Red Grouper length samples collected between 1981 and 2017 from recreational fisheries in the Gulf of Mexico by mode and data source (MRIP versus Other Sources [see **Table 2.26**]).

Mode	MRIP		Other Sources		Total
	Number	Percent	Number	Percent	
Charter	14,696	82.8	3,061	17.2	17,757
Headboat	342	5.8	5,506	94.2	5,848
Private	7,687	90.9	766	9.1	8,453
Recreational combined	22,725	70.9	9,333	29.1	32,058

**Table 2.28.** Proportions of imputed Red Grouper MRIP length data by number and by weighting from 1981 to 2017 (weighting factor: variable ‘wp\_size’).

Year	Imputed N	Total N	Proportion Imputed	Imputed weighting	Total weighting	Proportion imputed (weighting)
1981	88	130	0.68	423,398	722,030	0.59
1982	70	150	0.47	318,804	689,112	0.46
1983	66	161	0.41	300,880	1,243,476	0.24
1984	103	237	0.43	425,634	774,109	0.55
1985	182	221	0.82	1,260,279	1,346,680	0.94
1986	475	905	0.52	1,133,259	1,234,842	0.92
1987	213	878	0.24	417,833	828,634	0.50
1988	331	915	0.36	1,002,504	1,573,195	0.64
1989	183	1,080	0.17	1,295,617	2,311,193	0.56
1990	50	346	0.14	271,240	530,350	0.51
1991	47	296	0.16	182,510	594,662	0.31
1992	181	596	0.30	451,780	911,385	0.50
1993	148	382	0.39	429,019	668,828	0.64
1994	202	496	0.41	346,901	572,020	0.61
1995	155	385	0.40	308,333	566,519	0.54
1996	75	311	0.24	75,382	146,070	0.52
1997	50	260	0.19	102,249	173,530	0.59
1998	92	413	0.22	82,915	222,368	0.37
1999	227	736	0.31	252,318	499,885	0.50
2000	260	845	0.31	268,198	603,951	0.44
2001	215	760	0.28	153,274	361,478	0.42
2002	331	1,202	0.28	243,550	446,774	0.55
2003	429	1,524	0.28	206,120	349,394	0.59
2004	1,011	2,797	0.36	659,301	1,220,033	0.54
2005	676	2,011	0.34	234,499	471,628	0.50
2006	305	881	0.35	199,996	372,806	0.54
2007	246	731	0.34	183,897	312,545	0.59
2008	150	627	0.24	92,013	253,027	0.36
2009	132	590	0.22	122,972	205,167	0.60
2010	72	778	0.09	130,023	333,229	0.39
2011	200	1,216	0.16	112,463	275,546	0.41
2012	319	1,592	0.20	316,511	682,991	0.46
2013	310	1,675	0.19	414,174	858,752	0.48
2014	354	1,887	0.19	369,500	862,011	0.43
2015	277	1,744	0.16	302,781	537,023	0.56
2016	206	1,481	0.14	225,294	401,912	0.56
2017	130	815	0.16	113,000	245,567	0.46

**Table 2.29.** Number of observed and imputed Red Grouper length samples collected between 1981 and 2017 from recreational charter, headboat, and private fishery modes in the Gulf of Mexico by data sources. Data sources are as defined in **Table 2.26**.

Dataset	Source	Observed	Imputed
GulfFIN	FIN-OBS	19	
	FWRI-OBS	1,770	
	GRFS	485	
	RECFIN	1,795	
MRIP	MRIP	14,164	8,561
SRHS	SRHS	4,505	
TIP	TIP	759	

**Table 2.30.** Sample sizes of Red Grouper length samples collected between 1981 and 2017 from recreational charter, headboat, and private fishery modes in the Gulf of Mexico by mode.

Year	Charter/Private (MRIP)			Headboat
	Observed	Imputed	Total	All lengths
1981	22	65	87	43
1982	75	70	145	5
1983	60	23	83	78
1984	68	41	109	109
1985	11	103	114	107
1986	60	475	535	370
1987	119	213	332	546
1988	231	331	562	353
1989	198	183	381	699
1990	56	50	106	240
1991	104	47	151	109
1992	331	181	512	56
1993	137	148	285	36
1994	159	202	361	56
1995	170	155	325	57
1996	65	75	140	79
1997	72	50	122	69
1998	189	92	281	49
1999	376	227	603	112
2000	514	260	774	69
2001	484	215	699	55
2002	603	331	934	144
2003	743	429	1,172	219
2004	1,499	1,011	2,510	175
2005	1,165	676	1,841	95
2006	452	305	757	87
2007	294	246	540	137
2008	266	150	416	123
2009	172	132	304	163
2010	258	72	330	160
2011	371	200	571	261
2012	698	319	1,017	302
2013	841	310	1,151	231
2014	1,232	354	1,586	125
2015	909	277	1,186	94
2016	696	206	902	166
2017	329	130	459	69
Total	14,029	8,354	22,383	5,848

**Table 2.31.** Sample sizes of Red Grouper age samples collected between 1991 and 2017 from recreational fisheries in the Gulf of Mexico.

Year	Charter	Headboat	Private	Total
1991	1	36		37
1992	26	33	1	60
1993	61	21	1	83
1994	72	29		101
1995	91	53		144
1996	134	41		175
1997	61	28	9	98
1998	72	21	4	97
1999	104	8	2	114
2000	59	12		71
2001	46	1	2	49
2002	294	50	5	349
2003	101	30	68	199
2004	144	43	29	216
2005	64	52	1	117
2006	38	33	4	75
2007	52	28	8	88
2008	73	44	32	149
2009	90	109	26	225
2010	258	91	41	390
2011	413	114	28	555
2012	224	39	14	277
2013	216	45	25	286
2014	114	30	19	163
2015	225	71	61	357
2016	224	99	75	398
2017	138	28	86	252
<b>Total</b>	<b>3,395</b>	<b>1,189</b>	<b>541</b>	<b>5,125</b>

**Table 2.32.** Age composition of landed Red Grouper for the recreational fishery (reweighted by the length frequency to account for non-representative sampling) using the continuity approach from SEDAR42. Adjusted sample sizes (N adj) were obtained by taking the square root of observed sample sizes (N) and rescaling them during the assessment process using the Francis iterative reweighting approach. Data bars indicate the relative magnitude of the annual age frequency.

Year	N	N adj	Age-1	Age-2	Age-3	Age-4	Age-5	Age-6	Age-7	Age-8	Age-9	Age-10	Age-11	Age-12	Age-13	Age-14	Age-15	Age-16	Age-17	Age-18	Age-19	Age-20+
1991	37	7.8	0.00	0.00	0.03	0.14	0.47	0.16	0.05	0.04	0.01	0.04	0.01	0.01	0.02	0.00	0.00	0.00	0.00	0.00	0.00	0.02
1992	60	10.4	0.00	0.00	0.03	0.07	0.45	0.21	0.07	0.04	0.07	0.02	0.02	0.02	0.01	0.00	0.00	0.00	0.00	0.00	0.00	0.00
1993	83	11.7	0.00	0.01	0.06	0.28	0.14	0.14	0.14	0.11	0.06	0.01	0.02	0.00	0.01	0.00	0.00	0.00	0.00	0.00	0.00	0.00
1994	101	13.0	0.00	0.00	0.03	0.29	0.25	0.14	0.13	0.07	0.02	0.03	0.01	0.01	0.01	0.01	0.00	0.00	0.00	0.00	0.00	0.01
1995	144	15.6	0.00	0.00	0.00	0.07	0.30	0.28	0.18	0.10	0.03	0.01	0.01	0.01	0.00	0.01	0.00	0.00	0.00	0.00	0.00	0.00
1996	175	16.9	0.00	0.00	0.00	0.00	0.19	0.42	0.23	0.07	0.06	0.02	0.00	0.00	0.00	0.00	0.00	0.00	0.00	0.00	0.00	0.00
1997	98	13.0	0.00	0.00	0.01	0.05	0.09	0.29	0.38	0.11	0.02	0.00	0.01	0.00	0.00	0.00	0.00	0.00	0.00	0.00	0.00	0.00
1998	97	13.0	0.00	0.00	0.00	0.07	0.32	0.31	0.20	0.08	0.01	0.00	0.00	0.00	0.00	0.01	0.00	0.00	0.00	0.00	0.00	0.00
1999	114	14.3	0.00	0.00	0.02	0.05	0.45	0.21	0.08	0.10	0.05	0.04	0.00	0.00	0.00	0.00	0.00	0.00	0.00	0.00	0.00	0.00
2000	71	10.4	0.00	0.00	0.00	0.40	0.19	0.16	0.06	0.09	0.05	0.02	0.01	0.00	0.01	0.00	0.00	0.00	0.00	0.00	0.00	0.00
2001	49	9.1	0.00	0.00	0.00	0.04	0.59	0.24	0.12	0.00	0.00	0.00	0.00	0.00	0.00	0.00	0.00	0.00	0.00	0.00	0.00	0.00
2002	349	24.7	0.00	0.00	0.02	0.09	0.23	0.43	0.13	0.05	0.02	0.01	0.01	0.01	0.01	0.00	0.01	0.00	0.00	0.00	0.00	0.00
2003	199	18.2	0.00	0.00	0.03	0.48	0.15	0.12	0.15	0.02	0.02	0.01	0.00	0.01	0.00	0.00	0.00	0.00	0.00	0.00	0.00	0.00
2004	216	19.5	0.00	0.00	0.01	0.05	0.66	0.12	0.06	0.07	0.01	0.02	0.01	0.00	0.00	0.00	0.00	0.00	0.00	0.00	0.00	0.00
2005	117	14.3	0.00	0.00	0.00	0.04	0.21	0.55	0.11	0.03	0.04	0.01	0.00	0.00	0.00	0.01	0.00	0.00	0.00	0.00	0.00	0.00
2006	75	11.7	0.00	0.00	0.00	0.01	0.10	0.14	0.48	0.16	0.06	0.02	0.01	0.00	0.00	0.00	0.00	0.00	0.00	0.00	0.00	0.00
2007	88	11.7	0.00	0.00	0.05	0.06	0.08	0.15	0.20	0.36	0.04	0.00	0.01	0.01	0.04	0.01	0.00	0.00	0.00	0.00	0.00	0.00
2008	149	15.6	0.00	0.00	0.01	0.20	0.20	0.25	0.08	0.09	0.14	0.01	0.01	0.00	0.00	0.01	0.00	0.00	0.00	0.00	0.00	0.00
2009	225	19.5	0.00	0.00	0.23	0.07	0.23	0.15	0.16	0.05	0.07	0.03	0.01	0.01	0.00	0.00	0.00	0.00	0.00	0.00	0.00	0.00
2010	390	26.0	0.00	0.00	0.03	0.58	0.04	0.13	0.06	0.10	0.01	0.03	0.01	0.00	0.00	0.00	0.00	0.00	0.00	0.00	0.00	0.00
2011	555	31.2	0.00	0.00	0.00	0.08	0.74	0.07	0.03	0.03	0.03	0.01	0.01	0.01	0.00	0.00	0.00	0.00	0.00	0.00	0.00	0.00
2012	277	22.1	0.00	0.00	0.00	0.01	0.34	0.49	0.06	0.01	0.01	0.03	0.02	0.01	0.02	0.00	0.00	0.00	0.00	0.00	0.00	0.00
2013	286	22.1	0.00	0.00	0.00	0.01	0.03	0.58	0.33	0.01	0.01	0.00	0.01	0.00	0.00	0.02	0.00	0.00	0.00	0.00	0.00	0.00
2014	163	16.9	0.00	0.00	0.00	0.01	0.06	0.06	0.62	0.19	0.02	0.02	0.00	0.00	0.00	0.01	0.01	0.00	0.00	0.00	0.00	0.00
2015	357	24.7	0.00	0.00	0.01	0.02	0.20	0.15	0.15	0.30	0.13	0.01	0.01	0.01	0.00	0.00	0.01	0.01	0.00	0.00	0.00	0.00
2016	398	26.0	0.00	0.00	0.00	0.10	0.16	0.32	0.14	0.07	0.09	0.07	0.01	0.01	0.00	0.00	0.00	0.00	0.00	0.00	0.00	0.00
2017	252	20.8	0.00	0.01	0.03	0.06	0.22	0.19	0.14	0.06	0.07	0.11	0.07	0.02	0.00	0.01	0.01	0.01	0.01	0.00	0.01	0.00

**Table 2.33.** Difference in recreational age composition of Red Grouper and sample size (N) from the previous assessment (SEDAR61 Value – SEDAR42 Value). Larger differences identified by shading (red: SEDAR61 higher, blue: SEDAR61 lower).

Year	N	Age-1	Age-2	Age-3	Age-4	Age-5	Age-6	Age-7	Age-8	Age-9	Age-10	Age-11	Age-12	Age-13	Age-14	Age-15	Age-16	Age-17	Age-18	Age-19	Age-20+
1991	0	0.000	0.000	0.001	0.010	0.001	-0.023	0.008	0.001	0.000	0.001	0.000	0.000	0.000	0.000	0.000	0.000	0.000	0.000	0.000	0.000
1992	2	0.000	0.000	0.010	-0.011	-0.006	-0.009	0.016	0.001	0.000	0.001	0.000	-0.001	0.000	0.000	0.000	0.000	0.000	0.000	0.000	0.000
1993	0	0.000	0.009	0.024	-0.034	0.001	0.002	-0.003	0.000	0.001	-0.002	0.001	0.000	0.000	0.000	0.000	0.000	0.000	0.002	0.000	0.000
1994	0	0.000	0.000	-0.003	0.041	-0.043	-0.004	0.009	-0.003	0.000	0.003	-0.001	0.000	-0.001	0.000	0.000	0.000	0.000	0.000	0.000	0.000
1995	0	0.000	0.000	0.000	0.009	-0.003	-0.003	-0.003	0.001	0.000	0.000	0.000	0.000	0.000	0.000	0.000	0.000	0.000	0.000	0.000	0.000
1996	0	0.000	0.000	0.000	0.000	0.003	-0.004	0.002	-0.001	0.000	0.000	0.000	0.000	0.000	0.000	0.000	0.000	0.000	0.000	0.000	0.000
1997	0	0.000	0.000	0.000	0.000	0.000	0.000	0.000	0.000	0.000	0.000	0.000	0.000	0.000	0.000	0.000	0.000	0.000	0.000	0.000	0.000
1998	0	0.000	0.000	0.000	0.000	0.000	0.000	0.000	0.000	0.000	0.000	0.000	0.000	0.000	0.000	0.000	0.000	0.000	0.000	0.000	0.000
1999	0	0.000	0.000	0.000	0.000	0.000	0.000	0.000	0.000	0.000	0.000	0.000	0.000	0.000	0.000	0.000	0.000	0.000	0.000	0.000	0.000
2000	0	0.000	0.000	0.000	-0.007	0.012	-0.004	0.000	0.000	0.000	0.000	0.000	0.000	0.000	0.000	-0.004	0.004	0.000	0.000	0.000	0.000
2001	1	0.000	0.000	0.000	0.000	0.006	0.000	-0.006	0.000	0.000	0.000	0.000	0.000	0.000	0.000	0.000	0.000	0.000	0.000	0.000	0.000
2002	0	0.000	0.000	0.000	0.001	-0.001	0.003	-0.001	-0.001	0.000	0.000	0.001	0.000	0.000	0.000	0.000	0.000	0.000	0.000	0.000	0.000
2003	0	0.000	0.000	-0.001	-0.002	0.001	0.000	0.002	0.001	-0.001	0.000	0.000	0.001	0.000	0.000	0.000	0.000	0.000	0.000	0.000	0.000
2004	-12	0.000	0.000	0.001	0.002	0.008	0.006	-0.008	-0.001	-0.003	-0.007	0.001	0.000	0.000	0.001	0.000	0.000	0.000	0.000	0.000	0.000
2005	0	0.000	0.000	0.000	0.000	0.000	-0.023	0.021	0.001	0.000	0.000	0.000	0.000	0.000	0.001	0.000	0.000	0.000	0.000	0.000	0.000
2006	-2	0.000	0.000	0.000	0.000	0.002	0.002	0.043	-0.022	-0.026	0.000	0.001	0.000	0.000	0.000	0.002	-0.002	0.000	0.000	0.000	0.000
2007	-2	0.000	0.000	-0.001	0.002	0.001	0.003	-0.012	0.006	0.001	-0.004	0.002	0.001	0.001	0.000	0.000	0.000	0.000	0.000	0.000	0.000
2008	0	0.000	0.000	0.000	0.001	-0.009	0.008	-0.019	-0.009	0.026	0.000	0.000	0.000	0.000	0.000	0.000	0.000	0.000	0.000	0.000	0.000
2009	6	0.000	0.000	0.014	0.003	-0.003	-0.005	-0.008	0.010	-0.010	-0.001	-0.001	0.000	0.000	0.000	0.000	0.000	0.000	0.000	0.000	0.000
2010	-5	0.000	0.000	0.000	0.003	-0.005	-0.007	0.001	0.006	0.000	0.001	0.001	-0.003	0.000	0.001	0.000	0.000	0.000	0.000	0.002	0.000
2011	37	0.000	0.001	-0.001	0.003	-0.021	0.012	0.002	-0.008	0.002	0.007	0.001	0.002	0.000	0.000	0.000	0.000	0.000	0.000	0.000	0.000
2012	1	0.000	0.000	0.000	0.000	-0.001	0.000	0.004	0.000	0.000	-0.004	0.002	-0.001	0.000	0.000	0.000	0.000	0.000	0.000	0.000	0.000
2013	0	0.000	0.000	0.000	-0.004	-0.063	-0.023	0.088	0.001	0.001	0.000	-0.001	0.000	0.000	0.000	0.000	0.000	0.000	0.000	0.000	0.000

**Table 2.34.** Age composition of landed Red Grouper for the recreational fishery (reweighted by the length frequency to account for non-representative sampling) using the SEDAR61 recommended approach. Adjusted sample sizes (N adj) were obtained by taking the square root of observed sample sizes (N) and rescaling them during the assessment process using the Francis iterative reweighting approach. Data bars indicate the relative magnitude of the annual age frequency. Red text identifies years which were not included in modeling due to low sample sizes (N = 1 for MRIP charter/private data, N = 36 for headboat data).

Year	N	N adj	Age-1	Age-2	Age-3	Age-4	Age-5	Age-6	Age-7	Age-8	Age-9	Age-10	Age-11	Age-12	Age-13	Age-14	Age-15	Age-16	Age-17	Age-18	Age-19	Age-20+		
1991	37	7.8	0.00	0.00	0.00	0.00	0.01	0.00	0.00	0.00	0.00	0.00	0.00	0.00	0.00	0.00	0.00	0.00	0.00	0.00	0.00	0.00	0.98	
1992	60	10.4	0.00	0.00	0.00	0.21	0.45	0.00	0.00	0.05	0.25	0.02	0.01	0.01	0.00	0.00	0.00	0.00	0.00	0.00	0.00	0.00	0.00	0.00
1993	83	11.7	0.00	0.00	0.16	0.19	0.02	0.13	0.31	0.13	0.01	0.03	0.01	0.00	0.00	0.00	0.00	0.00	0.00	0.00	0.00	0.00	0.00	0.00
1994	101	13.0	0.00	0.00	0.02	0.25	0.21	0.25	0.17	0.08	0.00	0.01	0.00	0.01	0.00	0.00	0.00	0.00	0.00	0.00	0.00	0.00	0.00	0.00
1995	144	15.6	0.00	0.00	0.00	0.07	0.28	0.35	0.13	0.12	0.03	0.00	0.00	0.00	0.00	0.00	0.00	0.00	0.00	0.00	0.00	0.00	0.00	0.00
1996	175	16.9	0.00	0.00	0.00	0.00	0.16	0.49	0.23	0.07	0.03	0.01	0.00	0.00	0.00	0.00	0.00	0.00	0.00	0.00	0.00	0.00	0.00	0.00
1997	98	13.0	0.00	0.00	0.00	0.02	0.12	0.32	0.36	0.18	0.00	0.00	0.00	0.00	0.00	0.00	0.00	0.00	0.00	0.00	0.00	0.00	0.00	0.00
1998	97	13.0	0.00	0.00	0.00	0.08	0.34	0.26	0.23	0.08	0.00	0.00	0.00	0.00	0.00	0.00	0.00	0.00	0.00	0.00	0.00	0.00	0.00	0.00
1999	114	14.3	0.00	0.00	0.01	0.02	0.47	0.22	0.08	0.12	0.06	0.02	0.00	0.00	0.00	0.00	0.00	0.00	0.00	0.00	0.00	0.00	0.00	0.00
2000	71	10.4	0.00	0.00	0.00	0.23	0.25	0.18	0.06	0.15	0.08	0.02	0.00	0.00	0.02	0.00	0.00	0.00	0.00	0.00	0.00	0.00	0.00	0.00
2001	49	9.1	0.00	0.00	0.00	0.04	0.59	0.24	0.13	0.00	0.00	0.00	0.00	0.00	0.00	0.00	0.00	0.00	0.00	0.00	0.00	0.00	0.00	0.00
2002	349	24.7	0.00	0.00	0.01	0.08	0.20	0.43	0.15	0.06	0.02	0.00	0.01	0.01	0.01	0.00	0.00	0.00	0.00	0.00	0.00	0.00	0.00	0.00
2003	199	18.2	0.00	0.00	0.03	0.46	0.17	0.14	0.15	0.02	0.01	0.01	0.00	0.01	0.01	0.00	0.00	0.00	0.00	0.00	0.00	0.00	0.00	0.00
2004	216	19.5	0.00	0.00	0.01	0.06	0.68	0.08	0.07	0.05	0.01	0.02	0.01	0.00	0.00	0.02	0.00	0.00	0.00	0.00	0.00	0.00	0.00	0.00
2005	117	14.3	0.00	0.00	0.00	0.03	0.24	0.61	0.07	0.03	0.02	0.00	0.00	0.00	0.00	0.00	0.00	0.00	0.00	0.00	0.00	0.00	0.00	0.00
2006	75	11.7	0.00	0.00	0.00	0.00	0.12	0.16	0.39	0.23	0.02	0.03	0.04	0.00	0.00	0.00	0.00	0.00	0.00	0.00	0.00	0.00	0.00	0.00
2007	88	11.7	0.00	0.00	0.03	0.06	0.05	0.15	0.24	0.37	0.07	0.00	0.00	0.02	0.00	0.00	0.00	0.00	0.00	0.00	0.00	0.00	0.00	0.00
2008	149	15.6	0.00	0.00	0.02	0.23	0.23	0.24	0.11	0.09	0.05	0.00	0.03	0.00	0.00	0.00	0.00	0.00	0.00	0.00	0.00	0.00	0.00	0.00
2009	225	19.5	0.00	0.00	0.16	0.04	0.24	0.13	0.20	0.09	0.07	0.05	0.01	0.01	0.00	0.00	0.00	0.00	0.00	0.00	0.00	0.00	0.00	0.00
2010	390	26.0	0.00	0.00	0.02	0.65	0.04	0.15	0.05	0.05	0.01	0.02	0.00	0.00	0.00	0.00	0.00	0.00	0.00	0.00	0.00	0.00	0.00	0.00
2011	555	31.2	0.00	0.00	0.00	0.07	0.83	0.05	0.01	0.01	0.01	0.00	0.00	0.00	0.01	0.01	0.00	0.00	0.00	0.00	0.00	0.00	0.00	0.00
2012	277	22.1	0.00	0.00	0.00	0.01	0.28	0.48	0.07	0.01	0.00	0.07	0.02	0.01	0.04	0.00	0.00	0.00	0.00	0.00	0.00	0.00	0.01	0.00
2013	286	22.1	0.00	0.00	0.00	0.01	0.03	0.57	0.36	0.01	0.00	0.00	0.01	0.00	0.00	0.01	0.00	0.00	0.00	0.00	0.00	0.00	0.00	0.00
2014	163	16.9	0.00	0.00	0.00	0.00	0.06	0.07	0.62	0.20	0.02	0.01	0.00	0.00	0.00	0.02	0.00	0.00	0.00	0.00	0.00	0.00	0.00	0.00
2015	357	24.7	0.00	0.00	0.00	0.01	0.21	0.15	0.17	0.28	0.12	0.01	0.01	0.01	0.00	0.01	0.02	0.00	0.00	0.00	0.00	0.01	0.00	0.00
2016	398	26.0	0.00	0.00	0.00	0.10	0.15	0.35	0.15	0.06	0.10	0.07	0.01	0.01	0.00	0.01	0.00	0.00	0.00	0.00	0.00	0.00	0.00	0.00
2017	252	20.8	0.00	0.00	0.03	0.04	0.17	0.18	0.17	0.06	0.09	0.12	0.10	0.00	0.00	0.00	0.01	0.00	0.01	0.00	0.00	0.00	0.00	0.00



**Table 2.35.** Difference in recreational age composition of Red Grouper and sample size (N) from the previous assessment (SEDAR61 Value – SEDAR42 Value). Larger differences identified by shading (red: SEDAR61 higher, blue: SEDAR61 lower).

Year	N	Age-1	Age-2	Age-3	Age-4	Age-5	Age-6	Age-7	Age-8	Age-9	Age-10	Age-11	Age-12	Age-13	Age-14	Age-15	Age-16	Age-17	Age-18	Age-19	Age-20+	
1991	0	0.000	0.000	-0.032	-0.127	-0.462	-0.184	-0.037	-0.040	-0.009	-0.036	-0.011	-0.009	-0.016	0.000	0.000	0.000	0.000	0.000	0.000	0.000	0.963
1992	2	0.000	0.000	-0.022	0.123	-0.003	-0.214	-0.056	0.019	0.176	-0.005	-0.004	-0.008	-0.006	0.000	0.000	0.000	0.000	0.000	0.000	0.000	0.000
1993	0	0.000	-0.003	0.121	-0.123	-0.114	-0.006	0.167	0.019	-0.044	0.010	-0.013	0.000	-0.005	0.000	-0.004	0.000	0.000	0.000	-0.002	0.000	-0.004
1994	0	0.000	0.000	-0.014	0.000	-0.078	0.103	0.054	0.003	-0.012	-0.018	-0.011	0.001	-0.008	-0.005	0.000	0.000	0.000	0.000	0.000	0.000	-0.013
1995	0	0.000	0.000	0.000	0.009	-0.024	0.066	-0.052	0.025	-0.002	-0.005	-0.003	-0.008	-0.002	-0.002	0.000	-0.002	0.000	0.000	0.000	0.000	0.000
1996	0	0.000	0.000	-0.003	0.000	-0.030	0.064	0.005	0.000	-0.025	-0.007	0.000	0.000	-0.004	0.000	0.000	0.000	0.000	0.000	0.000	0.000	0.000
1997	0	0.000	0.000	-0.011	-0.023	0.024	0.025	-0.017	0.062	-0.017	-0.004	-0.014	-0.005	-0.005	-0.005	-0.005	-0.005	0.000	0.000	0.000	0.000	0.000
1998	0	0.000	0.000	0.000	0.009	0.017	-0.045	0.037	-0.001	-0.010	0.000	0.000	0.000	0.000	-0.007	0.000	0.000	0.000	0.000	0.000	0.000	0.000
1999	0	0.000	0.000	-0.008	-0.028	0.018	0.014	0.002	0.018	0.009	-0.022	0.000	0.000	0.000	0.000	0.000	-0.002	0.000	0.000	0.000	0.000	-0.002
2000	0	0.000	0.000	0.000	-0.177	0.075	0.014	0.005	0.058	0.025	0.002	-0.006	0.000	0.007	0.000	-0.004	0.000	0.002	0.000	0.000	0.000	-0.003
2001	1	0.000	0.000	0.000	-0.002	0.003	-0.002	0.004	0.000	0.000	-0.001	0.000	0.000	-0.001	0.000	0.000	0.000	-0.002	0.000	0.000	0.000	0.000
2002	0	0.000	0.000	-0.008	-0.009	-0.027	0.009	0.023	0.009	-0.002	0.001	-0.001	0.001	0.001	0.000	-0.004	0.000	0.000	0.000	0.000	0.000	0.000
2003	0	0.000	0.000	-0.003	-0.030	0.023	0.021	-0.003	0.000	-0.008	-0.005	0.000	0.001	0.003	0.000	0.000	0.000	0.000	0.000	0.000	0.000	0.000
2004	-12	0.000	0.000	0.002	0.019	0.029	-0.036	-0.005	-0.018	-0.007	-0.006	0.003	0.000	0.000	0.018	0.000	0.000	0.000	0.000	0.000	0.000	0.000
2005	0	0.000	0.000	0.000	-0.018	0.028	0.040	-0.019	0.001	-0.021	-0.005	0.001	0.000	0.000	-0.007	0.000	0.000	0.000	0.000	0.000	0.000	0.000
2006	-2	0.000	0.000	0.000	-0.010	0.014	0.022	-0.042	0.047	-0.064	0.004	0.031	0.000	0.000	0.000	0.001	-0.002	0.000	0.000	0.000	0.000	0.000
2007	-2	0.000	0.000	-0.015	0.002	-0.027	0.008	0.031	0.016	0.026	-0.005	-0.010	-0.024	-0.004	0.000	0.000	0.000	0.000	0.000	0.000	0.000	0.000
2008	0	0.000	0.000	0.010	0.030	0.016	-0.007	0.013	-0.005	-0.056	-0.012	0.015	0.000	0.000	-0.004	0.000	0.000	0.000	0.000	0.000	0.000	0.000
2009	6	0.000	-0.002	-0.052	-0.027	0.009	-0.023	0.030	0.051	-0.010	0.016	0.007	0.002	0.000	0.000	0.000	0.000	0.000	0.000	0.000	0.000	0.000
2010	-5	0.000	-0.002	-0.006	0.072	-0.004	0.011	-0.012	-0.043	-0.003	-0.007	-0.006	-0.003	0.000	-0.003	0.000	0.000	0.000	0.000	0.002	0.004	0.000
2011	37	0.000	0.000	-0.002	-0.010	0.070	-0.008	-0.017	-0.022	-0.014	-0.003	-0.004	0.000	0.005	0.005	0.000	0.000	0.000	0.000	0.000	0.000	0.000
2012	1	0.000	0.000	0.000	-0.003	-0.066	-0.003	0.010	0.006	-0.001	0.033	0.003	-0.002	0.024	0.000	-0.002	0.000	0.000	0.000	0.000	0.002	0.000
2013	0	0.000	0.000	-0.001	-0.003	-0.063	-0.035	0.118	0.002	0.000	0.000	-0.004	0.000	-0.003	-0.011	0.000	0.000	0.000	0.000	0.000	0.000	0.000

**Table 2.36.** Recreational discards (number of Red Grouper) provided for SEDAR61 and SEDAR42 by fishing mode, along with the ratio. Colors indicate the relative change in the discards, with blue (< 1) indicative of lower SEDAR61 discards, white indicative of values = 1.0 (identical discards), and red (> 1) indicative of higher SEDAR61 discards.

Year	SEDAR61			SEDAR42			Ratio (SEDAR61/SEDAR42)		
	Charter	Headboat	Private	Charter	Headboat	Private	Charter	Headboat	Private
1981	27,266	17,053	268,566	7,906	4,005	53,292	3.4	4.3	5.0
1982	5,296	3,312	158,497	3,078	1,559	35,734	1.7	2.1	4.4
1983	9,435	5,901	83,896	6,516	3,301	42,091	1.4	1.8	2.0
1984	48,761	30,497	83,694	18,893	9,570	27,223	2.6	3.2	3.1
1985	15,389	9,625	74,415	27,212	13,784	35,973	0.6	0.7	2.1
1986	86,363	46,587	813,907	75,968	57,059	388,292	1.1	0.8	2.1
1987	50,123	43,031	690,377	55,687	68,103	255,963	0.9	0.6	2.7
1988	70,652	79,240	1,932,133	45,691	44,776	727,407	1.5	1.8	2.7
1989	196,089	540,610	5,872,992	112,586	268,558	1,718,771	1.7	2.0	3.4
1990	196,883	72,542	4,374,994	217,875	115,232	1,244,607	0.9	0.6	3.5
1991	215,954	104,719	5,426,844	57,281	87,707	2,586,268	3.8	1.2	2.1
1992	204,602	66,174	5,157,606	165,448	52,245	2,115,433	1.2	1.3	2.4
1993	86,379	78,702	3,158,040	133,344	77,613	1,444,787	0.6	1.0	2.2
1994	146,510	84,039	3,236,051	119,009	65,148	1,344,305	1.2	1.3	2.4
1995	236,720	107,149	3,835,677	165,497	74,073	1,295,002	1.4	1.4	3.0
1996	114,829	163,725	1,246,516	62,371	78,145	705,629	1.8	2.1	1.8
1997	127,887	78,504	2,014,957	108,861	41,698	703,972	1.2	1.9	2.9
1998	202,616	83,492	3,337,806	326,922	101,358	1,139,286	0.6	0.8	2.9
1999	375,157	180,087	5,405,117	393,899	143,725	1,572,920	1.0	1.3	3.4
2000	471,536	98,791	4,227,094	634,966	80,840	1,524,541	0.7	1.2	2.8
2001	272,157	72,878	3,502,720	279,996	44,312	1,289,411	1.0	1.6	2.7
2002	228,016	63,624	3,909,476	273,975	44,637	1,571,390	0.8	1.4	2.5
2003	343,210	136,745	3,752,560	386,452	98,172	1,573,177	0.9	1.4	2.4
2004	423,964	160,995	7,512,527	452,240	123,862	2,697,519	0.9	1.3	2.8
2005	248,419	92,489	2,701,327	274,709	80,594	999,489	0.9	1.1	2.7
2006	123,352	32,695	2,220,260	127,967	29,164	503,284	1.0	1.1	4.4
2007	111,913	17,365	1,599,693	133,750	17,365	666,434	0.8	1.0	2.4
2008	367,994	89,615	6,294,612	425,320	89,615	2,549,796	0.9	1.0	2.5
2009	398,022	153,829	6,276,296	479,498	153,829	2,713,425	0.8	1.0	2.3
2010	497,987	117,879	5,379,955	543,936	117,879	1,667,811	0.9	1.0	3.2
2011	433,964	134,114	6,021,306	502,370	134,114	1,526,879	0.9	1.0	3.9
2012	464,256	117,809	4,392,740	539,422	117,809	1,202,880	0.9	1.0	3.7
2013	620,479	112,266	4,895,361	613,660	112,267	2,036,644	1.0	1.0	2.4
2014	435,470	84,237	4,293,342	-	-	-	-	-	-
2015	326,901	74,376	2,550,817	-	-	-	-	-	-
2016	322,165	79,409	2,164,044	-	-	-	-	-	-
2017	299,920	73,658	2,202,611	-	-	-	-	-	-

**Table 2.37.** Number of discarded Red Grouper observed on headboats and charters in Florida (2008 and 2014 excluded due to sampling issues [lack of funding in 2008 and special permits in 2014]). Note that charter samples in 2009 were not included in length composition analyses as this was an incomplete year of sampling.

Year	SEDAR 61		SEDAR42		Difference (SEDAR61-SEDAR42)	
	Headboat	Charter	Headboat	Charter	Headboat	Charter
2005	1,319		1,126		193	
2006	1,059		1,058		1	
2007	1,633		1,633		0	
2009	1,966	1,027	1,734		232	
2010	2,127	2,320	1,592	2,313	535	7
2011	1,671	1,842	1,056	1,834	615	8
2012	1,054	1,330	635	1,324	419	6
2013	1,072	1,179	772	1,195	300	-16
2015	631	1,259	-	-	-	-
2016	1,556	1,260	-	-	-	-
2017	1,641	1,652	-	-	-	-

**Table 2.38.** Size composition (2 cm length bins) of the recreational discards for Red Grouper. Adjusted sample sizes (N adj) were obtained by taking the square root of observed sample sizes (N) and rescaling them during the assessment process using the Francis iterative reweighting approach. Data bars indicate the relative magnitude of the annual length frequency.

Year	N	N adj	2	4	6	8	10	12	14	16	18	20	22	24	26	28	30	32	34	36	38	40	42	44	46	48
2006	1,319	8.3	0.00	0.00	0.00	0.00	0.00	0.00	0.00	0.00	0.01	0.02	0.04	0.07	0.06	0.06	0.07	0.10	0.12	0.09	0.06	0.08	0.06	0.07	0.06	0.02
2007	1,059	7.6	0.00	0.00	0.00	0.00	0.00	0.00	0.00	0.02	0.02	0.02	0.05	0.09	0.12	0.12	0.12	0.10	0.06	0.06	0.04	0.06	0.04	0.04	0.03	0.01
2008	1,633	9.2	0.00	0.00	0.00	0.00	0.00	0.00	0.00	0.00	0.02	0.04	0.10	0.13	0.15	0.13	0.09	0.05	0.04	0.05	0.04	0.03	0.03	0.03	0.03	0.01
2009	1,966	10.1	0.00	0.00	0.00	0.00	0.00	0.00	0.00	0.00	0.00	0.00	0.02	0.04	0.06	0.07	0.13	0.18	0.16	0.13	0.09	0.06	0.03	0.02	0.01	0.00
2010	4,447	15.4	0.00	0.00	0.00	0.00	0.00	0.00	0.00	0.00	0.00	0.00	0.00	0.01	0.03	0.07	0.15	0.15	0.15	0.14	0.11	0.07	0.05	0.03	0.02	0.01
2011	3,513	13.6	0.00	0.00	0.00	0.00	0.00	0.00	0.00	0.00	0.00	0.00	0.00	0.01	0.01	0.01	0.04	0.08	0.14	0.17	0.16	0.13	0.09	0.08	0.04	0.02
2012	2,384	11.3	0.00	0.00	0.00	0.00	0.00	0.00	0.00	0.00	0.00	0.00	0.00	0.01	0.02	0.03	0.04	0.05	0.06	0.08	0.12	0.17	0.16	0.13	0.09	0.03
2013	2,251	10.8	0.00	0.00	0.00	0.00	0.00	0.00	0.00	0.00	0.00	0.00	0.01	0.01	0.01	0.02	0.03	0.07	0.09	0.09	0.08	0.10	0.14	0.15	0.14	0.05
2015	1,890	9.9	0.00	0.00	0.00	0.00	0.00	0.00	0.00	0.00	0.00	0.00	0.01	0.02	0.02	0.04	0.07	0.09	0.11	0.12	0.11	0.09	0.10	0.08	0.06	0.04
2016	2,816	12.2	0.00	0.00	0.00	0.00	0.00	0.00	0.00	0.00	0.00	0.01	0.03	0.08	0.10	0.12	0.12	0.11	0.08	0.07	0.06	0.05	0.05	0.05	0.04	0.02
2017	3,293	13.1	0.00	0.00	0.00	0.00	0.00	0.00	0.00	0.00	0.00	0.01	0.02	0.07	0.11	0.13	0.15	0.11	0.12	0.10	0.06	0.04	0.03	0.02	0.02	0.01
Year	N	N adj	50	52	54	56	58	60	62	64	66	68	70	72	74	76	78	80	82	84	86	88	90	92	94	96
2006	1,319	8.3	0.01	0.00	0.00	0.00	0.00	0.00	0.00	0.00	0.00	0.00	0.00	0.00	0.00	0.00	0.00	0.00	0.00	0.00	0.00	0.00	0.00	0.00	0.00	0.00
2007	1,059	7.6	0.00	0.00	0.00	0.00	0.00	0.00	0.00	0.00	0.00	0.00	0.00	0.00	0.00	0.00	0.00	0.00	0.00	0.00	0.00	0.00	0.00	0.00	0.00	0.00
2008	1,633	9.2	0.01	0.00	0.00	0.00	0.00	0.00	0.00	0.00	0.00	0.00	0.00	0.00	0.00	0.00	0.00	0.00	0.00	0.00	0.00	0.00	0.00	0.00	0.00	0.00
2009	1,966	10.1	0.00	0.00	0.00	0.00	0.00	0.00	0.00	0.00	0.00	0.00	0.00	0.00	0.00	0.00	0.00	0.00	0.00	0.00	0.00	0.00	0.00	0.00	0.00	0.00
2010	4,447	15.4	0.00	0.00	0.00	0.00	0.00	0.00	0.00	0.00	0.00	0.00	0.00	0.00	0.00	0.00	0.00	0.00	0.00	0.00	0.00	0.00	0.00	0.00	0.00	0.00
2011	3,513	13.6	0.00	0.00	0.00	0.00	0.00	0.00	0.00	0.00	0.00	0.00	0.00	0.00	0.00	0.00	0.00	0.00	0.00	0.00	0.00	0.00	0.00	0.00	0.00	0.00
2012	2,384	11.3	0.00	0.00	0.00	0.00	0.00	0.00	0.00	0.00	0.00	0.00	0.00	0.00	0.00	0.00	0.00	0.00	0.00	0.00	0.00	0.00	0.00	0.00	0.00	0.00
2013	2,251	10.8	0.01	0.00	0.00	0.00	0.00	0.00	0.00	0.00	0.00	0.00	0.00	0.00	0.00	0.00	0.00	0.00	0.00	0.00	0.00	0.00	0.00	0.00	0.00	0.00
2015	1,890	9.9	0.01	0.01	0.01	0.00	0.00	0.00	0.00	0.00	0.00	0.00	0.00	0.00	0.00	0.00	0.00	0.00	0.00	0.00	0.00	0.00	0.00	0.00	0.00	0.00
2016	2,816	12.2	0.00	0.00	0.00	0.00	0.00	0.00	0.00	0.00	0.00	0.00	0.00	0.00	0.00	0.00	0.00	0.00	0.00	0.00	0.00	0.00	0.00	0.00	0.00	0.00
2017	3,293	13.1	0.00	0.00	0.00	0.00	0.00	0.00	0.00	0.00	0.00	0.00	0.00	0.00	0.00	0.00	0.00	0.00	0.00	0.00	0.00	0.00	0.00	0.00	0.00	0.00

**Table 2.39.** Difference in recreational discard length composition (2 cm length bins) of Red Grouper and sample size (N) from the previous assessment (SEDAR61 Value – SEDAR42 Value). Larger differences identified by shading (red: SEDAR61 higher, blue: SEDAR61 lower).

Year	N	2	4	6	8	10	12	14	16	18	20	22	24	26	28	30	32
2005	193	0.000	0.000	0.000	0.000	0.000	0.000	0.000	0.000	-0.001	-0.006	-0.005	0.003	-0.005	-0.005	-0.003	-0.006
2006	1	0.000	0.000	0.000	0.000	0.000	0.000	-0.001	-0.001	-0.001	-0.002	-0.009	-0.012	0.001	-0.003	-0.011	-0.012
2007	0	0.000	0.000	0.000	0.000	0.000	0.000	0.000	-0.001	-0.003	-0.004	-0.012	-0.011	-0.016	-0.021	-0.016	-0.006
2009	232	0.000	0.000	0.000	0.000	0.000	0.000	0.000	0.000	0.000	0.000	-0.003	-0.005	-0.006	-0.008	-0.016	-0.024
2010	542	0.000	0.000	0.000	0.000	0.000	0.000	0.000	0.000	0.000	0.000	-0.002	-0.005	-0.015	-0.045	-0.099	-0.111
2011	623	0.000	0.000	0.000	0.000	0.000	0.000	0.000	0.000	0.000	0.000	0.001	0.000	-0.001	-0.001	-0.007	-0.011
2012	425	0.000	0.000	0.000	0.000	0.000	0.000	0.000	0.000	0.000	-0.001	0.000	-0.001	-0.003	-0.001	0.002	0.024
2013	284	0.000	0.000	0.000	0.000	-0.001	0.000	0.000	0.000	0.000	0.000	0.000	-0.001	-0.001	-0.007	-0.012	-0.035
Year	N	34	36	38	40	42	44	46	48	50	52	54	56	58	60	62	64
2005	193	-0.012	-0.019	-0.016	-0.016	-0.017	-0.021	-0.013	-0.004	-0.003	-0.002	-0.001	0.000	0.000	0.000	0.000	0.000
2006	1	-0.012	-0.014	-0.011	-0.019	-0.011	-0.014	-0.011	-0.004	-0.001	0.000	0.000	0.000	0.000	0.000	0.000	0.000
2007	0	-0.008	-0.010	-0.006	-0.005	-0.008	-0.007	-0.007	-0.007	-0.002	0.000	0.000	0.000	0.000	0.000	0.000	0.000
2009	232	-0.026	-0.023	-0.016	-0.010	-0.006	-0.003	-0.002	0.000	0.000	0.000	0.000	0.000	0.000	0.000	0.000	0.000
2010	542	-0.110	-0.115	-0.046	0.055	0.127	0.163	0.109	0.074	0.018	0.001	0.001	0.001	0.000	0.000	0.000	0.000
2011	623	-0.037	-0.078	-0.091	-0.059	0.020	0.067	0.129	0.072	0.002	0.001	-0.001	-0.002	-0.001	-0.001	0.000	0.000
2012	425	0.085	0.086	0.049	0.002	-0.038	-0.087	-0.081	-0.028	-0.002	-0.002	0.001	-0.003	-0.001	-0.001	0.000	-0.001
2013	284	-0.004	0.056	0.099	0.129	0.048	-0.087	-0.126	-0.051	-0.001	-0.001	-0.001	-0.002	-0.001	0.000	0.000	-0.001
Year	N	66	68	70	72	74	76	78	80	82	84	86	88	90	92	94	96
2005	193	0.000	0.000	0.000	0.000	0.000	0.000	0.000	0.000	0.000	0.000	0.000	0.000	0.000	0.000	0.000	0.000
2006	1	0.000	0.000	0.000	0.000	0.000	0.000	0.000	0.000	0.000	0.000	0.000	0.000	0.000	0.000	0.000	0.000
2007	0	0.000	0.000	0.000	0.000	0.000	0.000	0.000	0.000	0.000	0.000	0.000	0.000	0.000	0.000	0.000	0.000
2009	232	0.000	0.000	0.000	0.000	0.000	0.000	0.000	0.000	0.000	0.000	0.000	0.000	0.000	0.000	0.000	0.000
2010	542	0.000	0.000	0.000	0.000	0.000	0.000	0.000	0.000	0.000	0.000	0.000	0.000	0.000	0.000	0.000	0.000
2011	623	0.000	0.000	0.000	-0.001	0.000	0.000	0.000	0.000	0.000	0.000	0.000	0.000	0.000	0.000	0.000	0.000
2012	425	0.000	0.000	0.000	-0.001	0.000	-0.001	0.000	0.000	0.000	0.000	0.000	0.000	0.000	0.000	0.000	0.000
2013	284	0.000	0.000	0.000	0.000	0.000	0.000	0.000	0.000	0.000	0.000	0.000	0.000	0.000	0.000	0.000	0.000

**Table 2.40.** Fishery-dependent standardized CPUE indices and associated coefficients of variation for Red Grouper derived from recreational surveys. All indices are scaled to a mean of one over each respective time series. The standard errors used in the SEDAR61 Assessment Model were scaled to a common mean of 0.3 (to provide equal weighting of all indices in the assessment model).

Year	Headboat		MRIP (MRFSS)	
	Index	CV	Index	CV
1986	1.189	0.674	0.915	0.281
1987	1.775	0.621	0.859	0.292
1988	1.735	0.605	1.757	0.354
1989	1.721	0.632	1.154	0.314
1990	0.748	0.732	1.69	0.277
1991	0.503	0.784	1.611	0.317
1992	0.428	0.805	1.275	0.269
1993	0.616	0.722	1.027	0.303
1994	0.658	0.711	0.87	0.311
1995	0.922	0.668	0.843	0.322
1996	0.523	0.752	0.465	0.375
1997	0.528	0.746	0.551	0.375
1998	0.562	0.744	0.696	0.316
1999	0.484	0.755	0.833	0.297
2000	0.573	0.751	0.805	0.307
2001	0.944	0.666	0.655	0.315
2002	0.884	0.664	0.743	0.315
2003	1.368	0.58	0.925	0.291
2004	2.088	0.53	1.154	0.259
2005	2.556	0.494	0.793	0.292
2006	0.935	0.656	0.412	0.371
2007	1.034	0.641	0.625	0.314
2008	0.982	0.631	1.236	0.252
2009	0.761	0.655	1.443	0.249
2010	1.13	0.592	1.216	0.266
2011	1.293	0.545	1.389	0.263
2012	1.593	0.523	1.049	0.264
2013	1.415	0.552	1.572	0.261
2014	0.78	0.62	1.286	0.259
2015	0.658	0.682	0.917	0.282
2016	0.379	0.746	0.527	0.314
2017	0.236	0.808	0.706	0.294

**Table 2.41.** Fishery-independent standardized indices of abundance and associated coefficients of variation for Red Grouper. All indices are scaled to a mean of one over each respective time series. The standard errors used in the SEDAR61 Assessment Model were scaled to a common mean of 0.3 (to provide equal weighting of all indices in the assessment model).

Year	SEAMAP Summer Groundfish		NMFS Bottom Longline		Combined Video		FWRI Repetitive Time Drop	
	Index	CV	Index	CV	Index	CV	Index	CV
1986	-	-	-	-	-	-	-	-
1987	-	-	-	-	-	-	-	-
1988	-	-	-	-	-	-	-	-
1989	-	-	-	-	-	-	-	-
1990	-	-	-	-	-	-	-	-
1991	-	-	-	-	-	-	-	-
1992	-	-	-	-	-	-	-	-
1993	-	-	-	-	0.795	0.165	-	-
1994	-	-	-	-	0.772	0.190	-	-
1995	-	-	-	-	0.893	0.214	-	-
1996	-	-	-	-	0.838	0.150	-	-
1997	-	-	-	-	1.132	0.117	-	-
1998	-	-	-	-	-	-	-	-
1999	-	-	-	-	-	-	-	-
2000	-	-	-	-	-	-	-	-
2001	-	-	0.772	0.290	-	-	-	-
2002	-	-	-	-	1.145	0.120	-	-
2003	-	-	1.022	0.202	-	-	-	-
2004	-	-	1.656	0.192	1.426	0.109	-	-
2005	-	-	0.584	0.407	1.214	0.087	-	-
2006	-	-	0.545	0.392	1.036	0.092	-	-
2007	-	-	0.863	0.465	0.725	0.124	-	-
2008	-	-	0.591	0.322	0.971	0.097	-	-
2009	1.852	0.252	0.915	0.264	1.444	0.074	-	-
2010	1.094	0.266	1.247	0.265	1.197	0.066	-	-
2011	0.979	0.295	2.327	0.181	1.316	0.053	-	-
2012	1.333	0.231	2.131	0.254	1.094	0.061	-	-
2013	0.650	0.284	0.985	0.305	1.043	0.078	-	-
2014	0.903	0.259	0.585	0.383	0.724	0.073	1.490	0.130
2015	0.691	0.299	0.717	0.361	0.565	0.092	0.840	0.190
2016	0.875	0.267	0.343	0.436	0.829	0.072	1.100	0.140
2017	0.623	0.337	0.717	0.342	0.841	0.064	0.580	0.220

**Table 2.42.** Size composition (2 cm length bins) of Red Grouper in the SEAMAP Summer Groundfish Survey. Adjusted sample sizes (N adj) were obtained by taking the square root of observed sample sizes (N) and rescaling them during the assessment process using the Francis iterative reweighting approach. Data bars indicate the relative magnitude of the annual length frequency.

Year	N	N adj	2	4	6	8	10	12	14	16	18	20	22	24	26	28	30	32	34	36	38	40	42	44	46	48	
2008	17	4.9	0.00	0.00	0.00	0.00	0.00	0.00	0.00	0.00	0.06	0.12	0.06	0.06	0.35	0.18	0.06	0.06	0.00	0.00	0.00	0.00	0.00	0.00	0.00	0.06	0.00
2009	171	15.9	0.00	0.00	0.01	0.01	0.00	0.00	0.01	0.01	0.02	0.04	0.13	0.21	0.18	0.09	0.04	0.05	0.08	0.04	0.03	0.01	0.01	0.02	0.00	0.01	0.01
2010	111	13.4	0.00	0.00	0.00	0.00	0.00	0.01	0.07	0.12	0.03	0.03	0.04	0.06	0.14	0.14	0.12	0.08	0.05	0.03	0.02	0.02	0.02	0.01	0.00	0.01	0.01
2011	113	13.4	0.00	0.01	0.00	0.00	0.00	0.01	0.02	0.12	0.06	0.03	0.06	0.07	0.06	0.09	0.03	0.07	0.07	0.06	0.09	0.03	0.03	0.02	0.00	0.01	0.01
2012	140	14.7	0.01	0.05	0.01	0.03	0.01	0.00	0.01	0.06	0.05	0.02	0.03	0.06	0.09	0.06	0.06	0.06	0.04	0.06	0.02	0.03	0.05	0.04	0.02	0.05	0.05
2013	65	9.8	0.00	0.00	0.02	0.02	0.00	0.05	0.02	0.02	0.05	0.08	0.03	0.05	0.05	0.05	0.02	0.09	0.05	0.03	0.05	0.06	0.08	0.08	0.02	0.00	0.00
2014	109	12.2	0.00	0.00	0.00	0.00	0.00	0.00	0.00	0.03	0.03	0.06	0.06	0.07	0.09	0.06	0.04	0.10	0.10	0.05	0.07	0.02	0.04	0.04	0.01	0.00	0.00
2015	114	13.4	0.00	0.00	0.00	0.00	0.00	0.05	0.05	0.09	0.21	0.17	0.00	0.04	0.04	0.03	0.04	0.04	0.05	0.04	0.03	0.00	0.02	0.02	0.03	0.01	0.01
2016	142	14.7	0.00	0.00	0.00	0.00	0.00	0.03	0.00	0.07	0.07	0.03	0.00	0.11	0.10	0.14	0.10	0.07	0.03	0.03	0.04	0.01	0.01	0.04	0.03	0.00	0.00
2017	53	8.6	0.00	0.00	0.00	0.00	0.00	0.02	0.02	0.08	0.04	0.04	0.09	0.17	0.17	0.04	0.11	0.06	0.08	0.02	0.00	0.02	0.02	0.00	0.02	0.00	0.00

Year	N	N adj	50	52	54	56	58	60	62	64	66	68	70	72	74	76	78	80	82	84	86	88	90	92	94	96	
2008	17	4.9	0.00	0.00	0.00	0.00	0.00	0.00	0.00	0.00	0.00	0.00	0.00	0.00	0.00	0.00	0.00	0.00	0.00	0.00	0.00	0.00	0.00	0.00	0.00	0.00	0.00
2009	171	15.9	0.00	0.01	0.00	0.01	0.00	0.00	0.00	0.00	0.00	0.00	0.00	0.00	0.00	0.00	0.00	0.00	0.00	0.00	0.00	0.00	0.00	0.00	0.00	0.00	0.00
2010	111	13.4	0.00	0.01	0.00	0.00	0.00	0.00	0.00	0.00	0.00	0.01	0.01	0.00	0.00	0.00	0.00	0.00	0.00	0.00	0.00	0.00	0.00	0.00	0.00	0.00	0.00
2011	113	13.4	0.02	0.01	0.01	0.00	0.01	0.00	0.00	0.00	0.00	0.01	0.00	0.00	0.00	0.01	0.00	0.01	0.00	0.00	0.00	0.00	0.00	0.00	0.00	0.00	0.00
2012	140	14.7	0.01	0.04	0.01	0.01	0.00	0.01	0.00	0.01	0.00	0.00	0.00	0.00	0.00	0.00	0.00	0.00	0.01	0.00	0.00	0.00	0.00	0.00	0.00	0.00	0.00
2013	65	9.8	0.03	0.02	0.03	0.00	0.00	0.02	0.00	0.02	0.00	0.00	0.02	0.00	0.02	0.00	0.00	0.00	0.00	0.00	0.00	0.00	0.00	0.00	0.00	0.00	0.00
2014	109	12.2	0.00	0.01	0.06	0.02	0.00	0.02	0.01	0.00	0.02	0.00	0.00	0.00	0.00	0.00	0.00	0.00	0.00	0.00	0.00	0.00	0.00	0.00	0.00	0.00	0.00
2015	114	13.4	0.01	0.01	0.00	0.02	0.00	0.03	0.00	0.00	0.00	0.00	0.00	0.00	0.00	0.00	0.00	0.00	0.00	0.00	0.00	0.00	0.00	0.00	0.00	0.00	0.00
2016	142	14.7	0.01	0.03	0.00	0.00	0.03	0.01	0.00	0.00	0.00	0.00	0.00	0.00	0.00	0.00	0.00	0.00	0.00	0.00	0.00	0.00	0.00	0.00	0.00	0.00	0.00
2017	53	8.6	0.00	0.02	0.00	0.00	0.00	0.00	0.00	0.00	0.00	0.00	0.00	0.00	0.00	0.00	0.00	0.00	0.00	0.00	0.00	0.00	0.00	0.00	0.00	0.00	0.00



**Table 2.43.** Difference in SEAMAP Summer Groundfish Survey length composition (2 cm length bins) of Red Grouper and sample size (N) from the previous assessment (SEDAR61 Value – SEDAR42 Value). Larger differences identified by shading (red: SEDAR61 higher, blue: SEDAR61 lower).

Year	N	2	4	6	8	10	12	14	16	18	20	22	24	26	28	30	32
2008	-16	0.000	0.000	-0.030	0.000	0.000	0.000	0.000	0.000	0.029	0.057	-0.032	-0.032	0.171	0.025	-0.062	-0.002
2009	-127	0.000	0.000	0.005	-0.001	-0.010	-0.017	0.002	0.005	0.010	0.015	0.051	0.090	0.038	-0.014	-0.049	-0.044
2010	-76	0.000	0.000	0.000	0.000	0.000	-0.002	0.024	0.042	0.006	0.011	0.009	0.026	0.050	0.032	-0.001	0.006
2011	-1	0.000	0.000	0.000	0.000	0.000	0.000	0.000	0.001	0.001	0.000	0.001	0.001	-0.008	0.001	0.000	0.001
2012	-11	0.001	0.004	0.001	0.002	-0.006	0.000	0.001	0.004	-0.010	0.002	0.002	0.005	0.000	0.005	-0.002	-0.002
2013	-7	0.000	0.000	0.001	0.001	0.000	0.004	0.001	0.001	-0.009	0.007	0.003	0.004	0.004	-0.037	0.001	0.009

Year	N	34	36	38	40	42	44	46	48	50	52	54	56	58	60	62	64
2008	-16	-0.061	0.000	0.000	-0.061	0.000	0.000	0.029	0.000	0.000	0.000	0.000	-0.030	0.000	0.000	0.000	0.000
2009	-127	-0.015	-0.026	-0.014	-0.011	-0.012	0.007	-0.003	-0.001	0.000	0.002	-0.003	0.005	0.000	0.000	-0.003	0.000
2010	-76	-0.041	-0.016	-0.062	-0.041	-0.014	-0.012	-0.011	-0.002	-0.005	0.004	0.000	0.000	0.000	-0.005	-0.005	0.000
2011	-1	0.001	0.001	0.001	0.000	0.000	0.000	0.000	0.000	0.000	0.000	0.000	0.000	0.000	0.000	0.000	0.000
2012	-11	0.003	-0.015	0.002	-0.005	0.004	0.003	0.002	-0.003	0.001	0.003	0.001	0.001	0.000	0.000	0.001	0.000
2013	-7	0.004	0.003	0.004	0.006	0.007	0.007	-0.012	0.000	-0.011	0.001	0.003	0.000	0.000	-0.012	0.000	0.001

Year	N	66	68	70	72	74	76	78	80	82	84	86	88	90	92	94	96
2008	-16	0.000	0.000	0.000	0.000	0.000	0.000	0.000	0.000	0.000	0.000	0.000	0.000	0.000	0.000	0.000	0.000
2009	-127	-0.003	-0.003	0.000	0.000	0.000	0.000	0.000	0.000	0.000	0.000	0.000	0.000	0.000	0.000	0.000	0.000
2010	-76	0.000	0.004	0.004	0.000	0.000	0.000	0.000	0.000	0.000	0.000	0.000	0.000	0.000	0.000	0.000	0.000
2011	-1	0.000	0.000	0.000	0.000	0.000	0.000	0.000	0.000	0.000	0.000	0.000	0.000	0.000	0.000	0.000	0.000
2012	-11	0.000	0.000	0.000	0.000	0.000	0.000	0.000	0.000	0.001	0.000	0.000	0.000	0.000	0.000	0.000	0.000
2013	-7	0.000	0.000	0.001	0.000	0.001	0.000	0.000	0.000	0.000	0.000	0.000	0.000	0.000	0.000	0.000	0.000

**Table 2.44.** Size composition (2 cm length bins) of Red Grouper in the NMFS Bottom Longline Survey. Adjusted sample sizes (N adj) were obtained by taking the square root of observed sample sizes (N) and rescaling them during the assessment process using the Francis iterative reweighting approach. Data bars indicate the relative magnitude of the annual length frequency.

Year	N	N adj	2	4	6	8	10	12	14	16	18	20	22	24	26	28	30	32	34	36	38	40	42	44	46	48	
2001	79	29.3	0.00	0.00	0.00	0.00	0.00	0.00	0.00	0.00	0.00	0.00	0.00	0.00	0.00	0.01	0.00	0.06	0.00	0.00	0.05	0.10	0.09	0.10	0.04	0.09	
2002	16	13.0	0.00	0.00	0.00	0.00	0.00	0.00	0.00	0.00	0.00	0.00	0.00	0.00	0.00	0.00	0.00	0.00	0.00	0.06	0.00	0.06	0.06	0.06	0.00	0.19	
2003	162	42.4	0.00	0.00	0.00	0.00	0.00	0.00	0.00	0.00	0.00	0.00	0.00	0.00	0.00	0.01	0.00	0.01	0.02	0.04	0.04	0.12	0.09	0.12	0.09	0.07	
2004	170	42.4	0.00	0.00	0.00	0.00	0.00	0.00	0.00	0.00	0.00	0.00	0.00	0.00	0.00	0.01	0.01	0.01	0.03	0.02	0.06	0.07	0.11	0.13	0.11	0.10	
2005	32	19.6	0.00	0.00	0.00	0.00	0.00	0.00	0.00	0.00	0.00	0.00	0.00	0.00	0.00	0.00	0.03	0.13	0.03	0.03	0.03	0.03	0.19	0.06	0.03	0.16	
2006	32	19.6	0.00	0.00	0.00	0.00	0.00	0.00	0.00	0.00	0.00	0.00	0.00	0.00	0.00	0.00	0.00	0.00	0.00	0.06	0.06	0.00	0.06	0.09	0.06	0.09	
2007	51	22.8	0.00	0.00	0.00	0.00	0.00	0.00	0.00	0.00	0.00	0.00	0.00	0.00	0.00	0.00	0.00	0.00	0.02	0.00	0.10	0.12	0.08	0.10	0.22	0.14	
2008	31	19.6	0.00	0.00	0.00	0.00	0.00	0.00	0.00	0.00	0.00	0.00	0.00	0.00	0.03	0.00	0.03	0.00	0.06	0.03	0.00	0.00	0.06	0.03	0.00	0.06	
2009	64	26.1	0.00	0.00	0.00	0.00	0.00	0.00	0.00	0.00	0.00	0.00	0.00	0.00	0.00	0.00	0.02	0.03	0.11	0.11	0.02	0.06	0.08	0.03	0.00	0.00	
2010	81	29.3	0.00	0.00	0.00	0.00	0.00	0.00	0.00	0.00	0.00	0.00	0.00	0.00	0.00	0.00	0.00	0.05	0.02	0.01	0.07	0.07	0.06	0.14	0.05	0.05	
2011	312	58.7	0.00	0.00	0.00	0.00	0.00	0.00	0.00	0.00	0.00	0.00	0.00	0.00	0.00	0.00	0.00	0.01	0.04	0.06	0.07	0.08	0.10	0.08	0.09	0.10	
2012	111	35.9	0.00	0.00	0.00	0.00	0.00	0.00	0.00	0.00	0.00	0.00	0.00	0.00	0.00	0.00	0.00	0.02	0.02	0.02	0.05	0.06	0.09	0.05	0.05	0.15	
2013	47	22.8	0.00	0.00	0.00	0.00	0.00	0.00	0.00	0.00	0.00	0.00	0.00	0.00	0.02	0.00	0.00	0.00	0.00	0.06	0.02	0.04	0.11	0.06	0.13	0.06	
2014	24	16.3	0.00	0.00	0.00	0.00	0.00	0.00	0.00	0.00	0.00	0.00	0.00	0.00	0.00	0.00	0.00	0.00	0.00	0.08	0.08	0.08	0.00	0.08	0.08	0.04	
2015	44	22.8	0.00	0.00	0.00	0.00	0.00	0.00	0.00	0.00	0.00	0.00	0.00	0.00	0.00	0.02	0.00	0.00	0.00	0.00	0.05	0.14	0.07	0.11	0.02	0.11	
2016	27	16.3	0.00	0.00	0.00	0.00	0.00	0.00	0.00	0.00	0.00	0.00	0.00	0.00	0.04	0.00	0.00	0.04	0.04	0.04	0.04	0.04	0.00	0.04	0.04	0.00	0.11
2017	35	19.6	0.00	0.00	0.00	0.00	0.00	0.00	0.00	0.00	0.00	0.00	0.00	0.00	0.00	0.03	0.03	0.03	0.06	0.06	0.06	0.03	0.00	0.00	0.06	0.03	

**Table 2.44 (Continued)** NMFS Bottom Longline Survey size composition in 2 cm length bins

Year	N	N adj	50	52	54	56	58	60	62	64	66	68	70	72	74	76	78	80	82	84	86	88	90	92	94	96	
2001	79	29.3	0.09	0.05	0.06	0.05	0.03	0.05	0.01	0.03	0.03	0.00	0.01	0.01	0.00	0.00	0.01	0.01	0.01	0.00	0.00	0.00	0.00	0.00	0.00	0.00	0.00
2002	16	13.0	0.19	0.00	0.00	0.00	0.00	0.13	0.00	0.06	0.13	0.00	0.00	0.00	0.00	0.00	0.06	0.00	0.00	0.00	0.00	0.00	0.00	0.00	0.00	0.00	0.00
2003	162	42.4	0.06	0.04	0.01	0.02	0.04	0.01	0.04	0.02	0.04	0.02	0.02	0.02	0.01	0.02	0.01	0.01	0.00	0.01	0.00	0.00	0.00	0.00	0.00	0.00	0.00
2004	170	42.4	0.06	0.03	0.04	0.03	0.01	0.02	0.04	0.00	0.02	0.04	0.02	0.02	0.02	0.00	0.01	0.00	0.00	0.00	0.00	0.00	0.00	0.00	0.00	0.00	0.00
2005	32	19.6	0.00	0.03	0.03	0.00	0.00	0.06	0.00	0.06	0.03	0.03	0.03	0.00	0.00	0.00	0.00	0.00	0.00	0.00	0.00	0.00	0.00	0.00	0.00	0.00	0.00
2006	32	19.6	0.06	0.06	0.16	0.03	0.06	0.03	0.03	0.00	0.13	0.00	0.00	0.00	0.00	0.00	0.00	0.00	0.00	0.00	0.00	0.00	0.00	0.00	0.00	0.00	0.00
2007	51	22.8	0.06	0.02	0.02	0.00	0.04	0.02	0.00	0.02	0.02	0.04	0.00	0.00	0.00	0.00	0.00	0.00	0.00	0.00	0.00	0.00	0.00	0.00	0.00	0.00	0.00
2008	31	19.6	0.03	0.10	0.06	0.03	0.06	0.06	0.00	0.10	0.13	0.00	0.00	0.03	0.03	0.00	0.00	0.00	0.00	0.00	0.00	0.00	0.00	0.00	0.00	0.00	0.00
2009	64	26.1	0.05	0.06	0.03	0.09	0.06	0.05	0.02	0.05	0.05	0.03	0.02	0.02	0.02	0.00	0.00	0.00	0.00	0.00	0.00	0.00	0.00	0.02	0.00	0.00	0.00
2010	81	29.3	0.05	0.11	0.05	0.02	0.04	0.00	0.05	0.04	0.02	0.02	0.00	0.02	0.01	0.00	0.01	0.01	0.00	0.00	0.00	0.00	0.00	0.00	0.00	0.00	0.00
2011	312	58.7	0.08	0.05	0.05	0.04	0.03	0.02	0.03	0.02	0.02	0.02	0.02	0.01	0.01	0.00	0.00	0.00	0.00	0.00	0.00	0.00	0.00	0.00	0.00	0.00	0.00
2012	111	35.9	0.06	0.14	0.06	0.03	0.05	0.03	0.04	0.02	0.04	0.00	0.02	0.01	0.01	0.00	0.00	0.00	0.00	0.00	0.00	0.00	0.00	0.00	0.00	0.00	0.00
2013	47	22.8	0.04	0.09	0.04	0.04	0.00	0.04	0.06	0.06	0.02	0.04	0.02	0.00	0.00	0.02	0.00	0.00	0.00	0.00	0.00	0.00	0.00	0.00	0.00	0.00	0.00
2014	24	16.3	0.08	0.00	0.04	0.00	0.00	0.08	0.04	0.08	0.17	0.00	0.00	0.00	0.00	0.04	0.00	0.00	0.00	0.00	0.00	0.00	0.00	0.00	0.00	0.00	0.00
2015	44	22.8	0.07	0.05	0.07	0.02	0.02	0.00	0.07	0.05	0.02	0.05	0.02	0.05	0.00	0.00	0.00	0.00	0.00	0.00	0.00	0.00	0.00	0.00	0.00	0.00	0.00
2016	27	16.3	0.04	0.07	0.04	0.11	0.04	0.00	0.07	0.04	0.04	0.00	0.00	0.04	0.04	0.04	0.04	0.04	0.00	0.00	0.00	0.00	0.00	0.00	0.00	0.00	0.00
2017	35	19.6	0.06	0.06	0.06	0.03	0.06	0.06	0.00	0.06	0.06	0.06	0.06	0.03	0.00	0.03	0.03	0.00	0.00	0.00	0.00	0.00	0.00	0.00	0.00	0.00	0.00

**Table 2.45.** Difference in NMFS Bottom Longline Survey length composition (2 cm length bins) of Red Grouper and sample size (N) from the previous assessment (SEDAR61 Value – SEDAR42 Value). Larger differences identified by shading (red: SEDAR61 higher, blue: SEDAR61 lower).

Year	N	2	4	6	8	10	12	14	16	18	20	22	24	26	28	30	32	34	36	38	40	42	44	46	48
2001	0	0.000	0.000	0.000	0.000	0.000	0.000	0.000	0.000	0.000	0.000	0.000	0.000	0.000	0.000	0.000	0.000	0.000	0.000	0.000	0.000	0.000	0.000	0.000	0.000
2002	0	0.000	0.000	0.000	0.000	0.000	0.000	0.000	0.000	0.000	0.000	0.000	0.000	0.000	0.000	0.000	0.000	0.000	0.000	0.000	0.000	0.000	0.000	0.000	0.000
2003	0	0.000	0.000	0.000	0.000	0.000	0.000	0.000	0.000	0.000	0.000	0.000	0.000	0.000	0.000	0.000	0.000	0.000	0.000	0.000	0.000	0.000	0.000	0.000	0.000
2004	0	0.000	0.000	0.000	0.000	0.000	0.000	0.000	0.000	0.000	0.000	0.000	0.000	0.000	0.000	0.000	0.000	0.000	0.000	0.000	0.000	0.000	0.000	0.000	0.000
2005	0	0.000	0.000	0.000	0.000	0.000	0.000	0.000	0.000	0.000	0.000	0.000	0.000	0.000	0.000	0.000	0.000	0.000	0.000	0.000	0.000	0.000	0.000	0.000	0.000
2006	0	0.000	0.000	0.000	0.000	0.000	0.000	0.000	0.000	0.000	0.000	0.000	0.000	0.000	0.000	0.000	0.000	0.000	0.000	0.000	0.000	0.000	0.000	0.000	0.000
2007	0	0.000	0.000	0.000	0.000	0.000	0.000	0.000	0.000	0.000	0.000	0.000	0.000	0.000	0.000	0.000	0.000	0.000	0.000	0.000	0.000	0.000	0.000	0.000	0.000
2008	0	0.000	0.000	0.000	0.000	0.000	0.000	0.000	0.000	0.000	0.000	0.000	0.000	0.000	0.000	0.000	0.000	0.000	0.000	0.000	0.000	0.000	0.000	0.000	0.000
2009	0	0.000	0.000	0.000	0.000	0.000	0.000	0.000	0.000	0.000	0.000	0.000	0.000	0.000	0.000	0.000	0.000	0.000	0.000	0.000	0.000	0.000	0.000	0.000	0.000
2010	0	0.000	0.000	0.000	0.000	0.000	0.000	0.000	0.000	0.000	0.000	0.000	0.000	0.000	0.000	0.000	0.000	0.000	0.000	0.000	0.000	0.000	0.000	0.000	0.000
2011	0	0.000	0.000	0.000	0.000	0.000	0.000	0.000	0.000	0.000	0.000	0.000	0.000	0.000	0.000	0.000	0.000	0.000	0.000	0.000	0.000	0.000	0.000	0.000	0.000
2012	0	0.000	0.000	0.000	0.000	0.000	0.000	0.000	0.000	0.000	0.000	0.000	0.000	0.000	0.000	0.000	0.000	0.000	0.000	0.000	0.000	0.000	0.000	0.000	0.000
2013	0	0.000	0.000	0.000	0.000	0.000	0.000	0.000	0.000	0.000	0.000	0.000	0.000	0.000	0.000	0.000	0.000	0.000	0.000	0.000	0.000	0.000	0.000	0.000	0.000

Year	N	50	52	54	56	58	60	62	64	66	68	70	72	74	76	78	80	82	84	86	88	90	92	94	96
2001	0	0.000	0.000	0.000	0.000	0.000	0.000	0.000	0.000	0.000	0.000	0.000	0.000	0.000	0.000	0.000	0.000	0.000	0.000	0.000	0.000	0.000	0.000	0.000	0.000
2002	0	0.000	0.000	0.000	0.000	0.000	0.000	0.000	0.000	0.000	0.000	0.000	0.000	0.000	0.000	0.000	0.000	0.000	0.000	0.000	0.000	0.000	0.000	0.000	0.000
2003	0	0.000	0.000	0.000	0.000	0.000	0.000	0.000	0.000	0.000	0.000	0.000	0.000	0.000	0.000	0.000	0.000	0.000	0.000	0.000	0.000	0.000	0.000	0.000	0.000
2004	0	0.000	0.000	0.000	0.000	0.000	0.000	0.000	0.000	0.000	0.000	0.000	0.000	0.000	0.000	0.000	0.000	0.000	0.000	0.000	0.000	0.000	0.000	0.000	0.000
2005	0	0.000	0.000	0.000	0.000	0.000	0.000	0.000	0.000	0.000	0.000	0.000	0.000	0.000	0.000	0.000	0.000	0.000	0.000	0.000	0.000	0.000	0.000	0.000	0.000
2006	0	0.000	0.000	0.000	0.000	0.000	0.000	0.000	0.000	0.000	0.000	0.000	0.000	0.000	0.000	0.000	0.000	0.000	0.000	0.000	0.000	0.000	0.000	0.000	0.000
2007	0	0.000	0.000	0.000	0.000	0.000	0.000	0.000	0.000	0.000	0.000	0.000	0.000	0.000	0.000	0.000	0.000	0.000	0.000	0.000	0.000	0.000	0.000	0.000	0.000
2008	0	0.000	0.000	0.000	0.000	0.000	0.000	0.000	0.000	0.000	0.000	0.000	0.000	0.000	0.000	0.000	0.000	0.000	0.000	0.000	0.000	0.000	0.000	0.000	0.000
2009	0	0.000	0.000	0.000	0.000	0.000	0.000	0.000	0.000	0.000	0.000	0.000	0.000	0.000	0.000	0.000	0.000	0.000	0.000	0.000	-0.016	0.000	0.016	0.000	0.000
2010	0	0.000	0.000	0.000	0.000	0.000	0.000	0.000	0.000	0.000	0.000	0.000	0.000	0.000	0.000	0.000	0.000	0.000	0.000	0.000	0.000	0.000	0.000	0.000	0.000
2011	0	0.000	0.000	0.000	0.000	0.000	0.000	0.000	0.000	0.000	0.000	0.000	0.000	0.000	0.000	0.000	0.000	0.000	0.000	0.000	0.000	0.000	0.000	0.000	0.000
2012	0	0.000	0.000	0.000	0.000	0.000	0.000	0.000	0.000	0.000	0.000	0.000	0.000	0.000	0.000	0.000	0.000	0.000	0.000	0.000	0.000	0.000	0.000	0.000	0.000
2013	0	0.000	0.000	0.000	0.000	0.000	0.000	0.000	0.000	0.000	0.000	0.000	0.000	0.000	0.000	0.000	0.000	0.000	0.000	0.000	0.000	0.000	0.000	0.000	0.000

**Table 2.46.** Survey effort for the three video surveys and the combined video totals.

Year	FWRI	SEAMAP Reef Fish (NMFS Mississippi Laboratories)	NMFS Panama City	Total
1993		115		115
1994		90		90
1995		61		61
1996		133		133
1997		162		162
2002		152		152
2004		149		149
2005		274		274
2006		276	70	346
2007		319	44	363
2008		206	85	291
2009		262	99	361
2010	145	221	143	509
2011	221	337	156	714
2012	237	281	150	668
2013	184	164	94	442
2014	286	230	153	669
2015	224	152	143	519
2016	194	206	168	568
2017	164	434	149	747
Total	1,655	4,224	1,454	7,333

**Table 2.47.** The habitat weighting used with the annual distribution of Fair, Good, and Poor habitats to adjust estimated model means to account for variation across surveys.

Survey	Total Universe Area (km <sup>2</sup> )	Proportion of grids with habitat	Total Universe area X Prop transects
FWRI	37290.0	0.29	10814.09
NMFS Panama City	22104.7	0.67	14860.90
SEAMAP Reef Fish	34490.0	0.81	27936.90

**Table 2.48.** Size composition (2 cm length bins) of Red Grouper in the Combined Video Survey (NMFS Panama City, SEAMAP Reef Fish, and FWRI zones 4 and 5). Adjusted sample sizes (N adj) were obtained by taking the square root of observed sample sizes (N) and rescaling them during the assessment process using the Francis iterative reweighting approach. Data bars indicate the relative magnitude of the annual length frequency.

Year	N	N adj	2	4	6	8	10	12	14	16	18	20	22	24	26	28	30	32	34	36	38	40	42	44	46	48
2008	32	9.0	0.00	0.00	0.00	0.00	0.00	0.00	0.00	0.00	0.00	0.00	0.03	0.00	0.03	0.00	0.03	0.03	0.06	0.00	0.00	0.03	0.00	0.09	0.09	0.06
2009	93	15.0	0.00	0.00	0.00	0.00	0.00	0.00	0.00	0.00	0.00	0.01	0.00	0.00	0.00	0.00	0.04	0.05	0.10	0.04	0.13	0.02	0.09	0.06	0.06	0.03
2010	83	13.5	0.00	0.00	0.00	0.00	0.00	0.00	0.00	0.00	0.00	0.00	0.00	0.00	0.05	0.01	0.02	0.02	0.02	0.07	0.02	0.01	0.11	0.08	0.07	0.05
2011	158	19.5	0.00	0.00	0.00	0.00	0.00	0.00	0.00	0.00	0.00	0.00	0.00	0.00	0.00	0.01	0.02	0.02	0.06	0.03	0.06	0.11	0.04	0.06	0.11	0.11
2012	193	21.0	0.00	0.00	0.00	0.00	0.00	0.00	0.00	0.00	0.00	0.00	0.00	0.01	0.02	0.01	0.00	0.03	0.04	0.03	0.07	0.03	0.07	0.06	0.06	0.07
2013	77	13.5	0.00	0.00	0.00	0.00	0.00	0.00	0.00	0.00	0.00	0.00	0.00	0.03	0.00	0.01	0.00	0.03	0.03	0.05	0.04	0.03	0.04	0.03	0.09	0.05
2014	161	19.5	0.00	0.00	0.00	0.00	0.00	0.00	0.00	0.01	0.01	0.00	0.00	0.02	0.00	0.04	0.02	0.02	0.03	0.07	0.04	0.06	0.11	0.06	0.03	0.04
2015	135	18.0	0.00	0.00	0.00	0.00	0.00	0.00	0.00	0.01	0.01	0.01	0.04	0.03	0.03	0.01	0.06	0.04	0.06	0.01	0.04	0.02	0.04	0.04	0.07	0.06
2016	126	16.5	0.00	0.00	0.00	0.00	0.00	0.00	0.01	0.02	0.01	0.00	0.02	0.01	0.04	0.06	0.04	0.03	0.03	0.02	0.04	0.06	0.02	0.06	0.03	0.02
2017	125	16.5	0.00	0.00	0.00	0.00	0.00	0.00	0.00	0.00	0.02	0.02	0.03	0.03	0.06	0.10	0.06	0.07	0.06	0.04	0.02	0.04	0.07	0.05	0.05	0.06

Year	N	N adj	50	52	54	56	58	60	62	64	66	68	70	72	74	76	78	80	82	84	86	88	90	92	94	96
2008	32	9.0	0.16	0.16	0.03	0.00	0.06	0.03	0.06	0.00	0.00	0.00	0.00	0.00	0.00	0.00	0.00	0.00	0.00	0.00	0.00	0.00	0.00	0.00	0.00	0.03
2009	93	15.0	0.04	0.04	0.06	0.01	0.05	0.01	0.00	0.02	0.01	0.02	0.02	0.01	0.02	0.00	0.01	0.00	0.01	0.00	0.00	0.00	0.00	0.00	0.00	0.00
2010	83	13.5	0.02	0.07	0.05	0.02	0.05	0.01	0.05	0.04	0.02	0.04	0.02	0.04	0.00	0.00	0.00	0.00	0.01	0.00	0.00	0.00	0.00	0.00	0.00	0.00
2011	158	19.5	0.04	0.04	0.04	0.03	0.01	0.02	0.07	0.03	0.03	0.02	0.02	0.01	0.01	0.02	0.01	0.01	0.01	0.00	0.00	0.00	0.00	0.00	0.00	0.00
2012	193	21.0	0.07	0.05	0.08	0.04	0.04	0.01	0.04	0.05	0.02	0.02	0.03	0.01	0.02	0.01	0.01	0.01	0.01	0.00	0.00	0.01	0.00	0.01	0.00	0.00
2013	77	13.5	0.09	0.06	0.05	0.06	0.06	0.05	0.03	0.03	0.00	0.04	0.04	0.01	0.01	0.00	0.01	0.01	0.01	0.00	0.00	0.00	0.00	0.00	0.00	0.00
2014	161	19.5	0.06	0.05	0.03	0.06	0.01	0.04	0.02	0.02	0.03	0.03	0.02	0.01	0.02	0.01	0.00	0.01	0.00	0.00	0.00	0.01	0.00	0.00	0.00	0.00
2015	135	18.0	0.05	0.03	0.04	0.07	0.03	0.04	0.05	0.02	0.02	0.01	0.01	0.00	0.01	0.00	0.01	0.01	0.00	0.00	0.00	0.00	0.00	0.00	0.00	0.00
2016	126	16.5	0.03	0.04	0.05	0.03	0.02	0.06	0.10	0.04	0.05	0.02	0.02	0.02	0.01	0.00	0.00	0.00	0.00	0.00	0.00	0.00	0.00	0.00	0.00	0.00
2017	125	16.5	0.03	0.02	0.04	0.03	0.02	0.02	0.01	0.01	0.01	0.00	0.04	0.01	0.00	0.00	0.00	0.01	0.01	0.00	0.00	0.00	0.00	0.00	0.00	0.00

**Table 2.49.** Difference in Combined Video Survey (PC, SEAMAP, and FWRI zones 4 and 5) length composition (2 cm length bins) of Red Grouper and sample size (N) from the previous assessment (SEDAR61 Value – SEDAR42 Value). Larger differences identified by shading (red: SEDAR61 higher, blue: SEDAR61 lower).

Year	N	2	4	6	8	10	12	14	16	18	20	22	24	26	28	30	32
2008	0	0.000	0.000	0.000	0.000	0.000	0.000	0.000	0.000	0.000	0.000	0.000	0.000	0.000	0.000	0.000	0.000
2009	-6	0.000	0.000	0.000	0.000	0.000	0.000	0.000	0.000	0.000	0.001	0.000	0.000	0.000	0.000	-0.007	-0.017
2010	35	0.000	0.000	0.000	0.000	0.000	0.000	0.000	0.000	0.000	0.000	0.000	0.000	0.027	0.012	-0.018	0.024
2011	42	0.000	0.000	0.000	0.000	0.000	0.000	0.000	0.000	0.000	0.000	0.000	0.000	0.000	-0.002	0.010	0.010
2012	88	0.000	0.000	0.000	0.000	0.000	0.000	0.000	0.000	0.000	0.000	0.000	-0.004	0.006	0.001	0.000	-0.012
2013	38	0.000	0.000	0.000	0.000	0.000	0.000	0.000	0.000	0.000	0.000	0.000	0.026	0.000	-0.013	0.000	0.000

Year	N	34	36	38	40	42	44	46	48	50	52	54	56	58	60	62	64
2008	0	0.000	0.000	0.000	0.000	0.000	0.000	0.000	0.000	0.000	0.000	0.000	0.000	0.000	0.000	0.000	0.000
2009	-6	0.006	0.003	-0.012	-0.029	0.005	0.004	0.004	0.002	0.003	0.013	0.004	0.001	0.013	0.001	0.000	0.001
2010	35	0.024	0.031	-0.018	-0.009	-0.037	-0.061	-0.032	-0.014	-0.018	0.031	-0.035	0.003	-0.014	0.012	0.027	0.015
2011	42	0.012	0.014	0.022	0.021	-0.005	0.005	-0.004	-0.030	-0.005	-0.014	-0.014	-0.009	-0.002	-0.007	0.009	-0.001
2012	88	-0.011	0.022	0.006	0.012	0.025	-0.004	-0.014	-0.004	-0.009	-0.011	-0.008	-0.021	-0.002	0.001	-0.006	-0.005
2013	38	0.026	-0.025	-0.012	-0.025	0.013	-0.025	-0.037	-0.025	0.091	0.014	0.001	0.014	-0.012	0.026	0.026	0.000

Year	N	66	68	70	72	74	76	78	80	82	84	86	88	90	92	94	96
2008	0	0.000	0.000	0.000	0.000	0.000	0.000	0.000	0.000	0.000	0.000	0.000	0.000	0.000	0.000	0.000	0.000
2009	-6	0.001	0.001	0.001	0.001	0.001	0.000	0.001	0.000	0.001	0.000	0.000	0.000	0.000	0.000	0.000	0.000
2010	35	0.003	-0.006	0.024	0.036	0.000	0.000	0.000	0.000	-0.009	0.000	0.000	0.000	0.000	0.000	0.000	0.000
2011	42	-0.001	0.002	-0.007	0.004	0.004	0.002	-0.002	-0.002	-0.011	0.000	0.000	0.000	0.000	0.000	0.000	0.000
2012	88	0.011	0.002	0.007	0.005	-0.008	-0.009	0.010	0.005	0.005	0.000	0.000	0.005	0.000	0.005	0.000	0.000
2013	38	0.000	-0.038	0.013	0.013	-0.013	0.000	-0.013	-0.013	-0.013	0.000	0.000	0.000	0.000	0.000	0.000	0.000

**Table 2.50.** Size composition (2 cm length bins) of Red Grouper in the FWRI Hook and Line Repetitive Time Drop Survey. Adjusted sample sizes (N adj) were obtained by taking the square root of observed sample sizes (N) and rescaling them during the assessment process using the Francis iterative reweighting approach. Data bars indicate the relative magnitude of the annual length frequency.

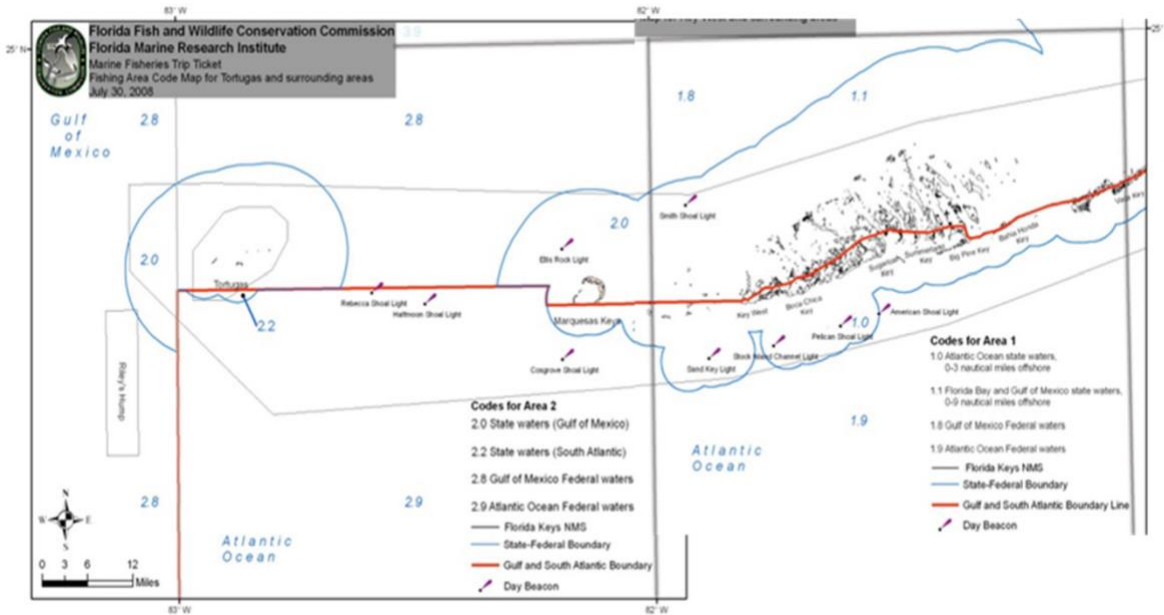
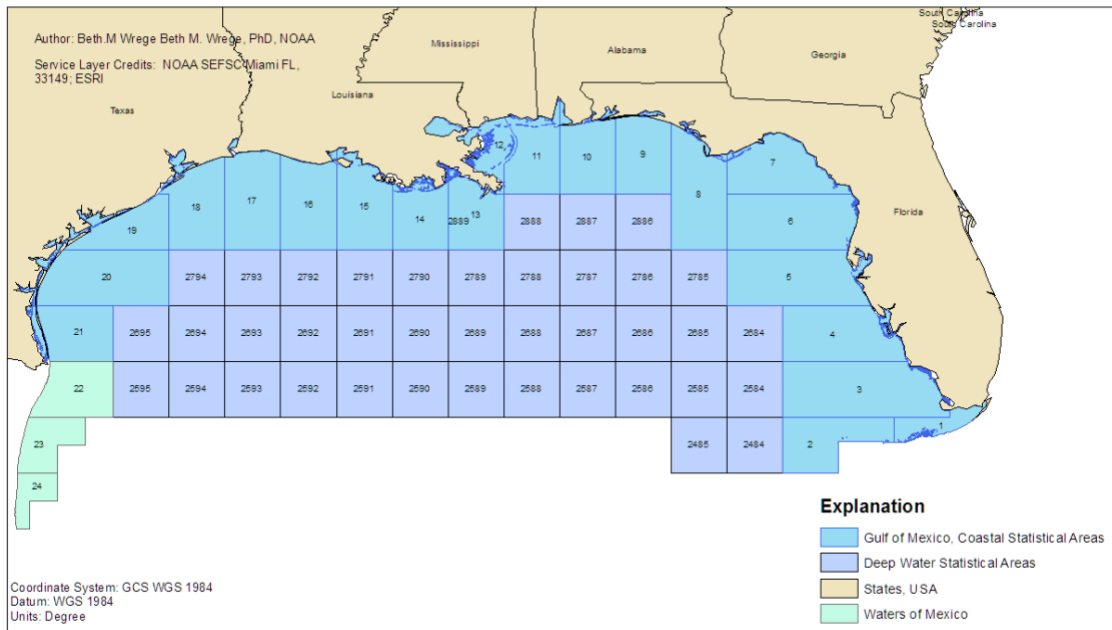
Year	N	N adj	2	4	6	8	10	12	14	16	18	20	22	24	26	28	30	32	34	36	38	40	42	44	46	48
2014	247	51.4	0.00	0.00	0.00	0.00	0.00	0.00	0.00	0.00	0.00	0.00	0.00	0.00	0.00	0.01	0.02	0.03	0.07	0.05	0.09	0.09	0.10	0.07	0.08	0.05
2015	106	32.1	0.00	0.00	0.00	0.00	0.00	0.00	0.00	0.00	0.00	0.05	0.06	0.01	0.00	0.00	0.01	0.01	0.01	0.02	0.03	0.05	0.06	0.09	0.11	0.04
2016	143	38.5	0.00	0.00	0.00	0.00	0.00	0.00	0.00	0.00	0.00	0.01	0.01	0.02	0.03	0.04	0.06	0.06	0.03	0.08	0.06	0.04	0.05	0.06	0.08	0.03
2017	58	25.7	0.00	0.00	0.00	0.00	0.00	0.00	0.00	0.00	0.00	0.00	0.05	0.02	0.05	0.05	0.00	0.10	0.17	0.14	0.07	0.02	0.03	0.07	0.02	0.05

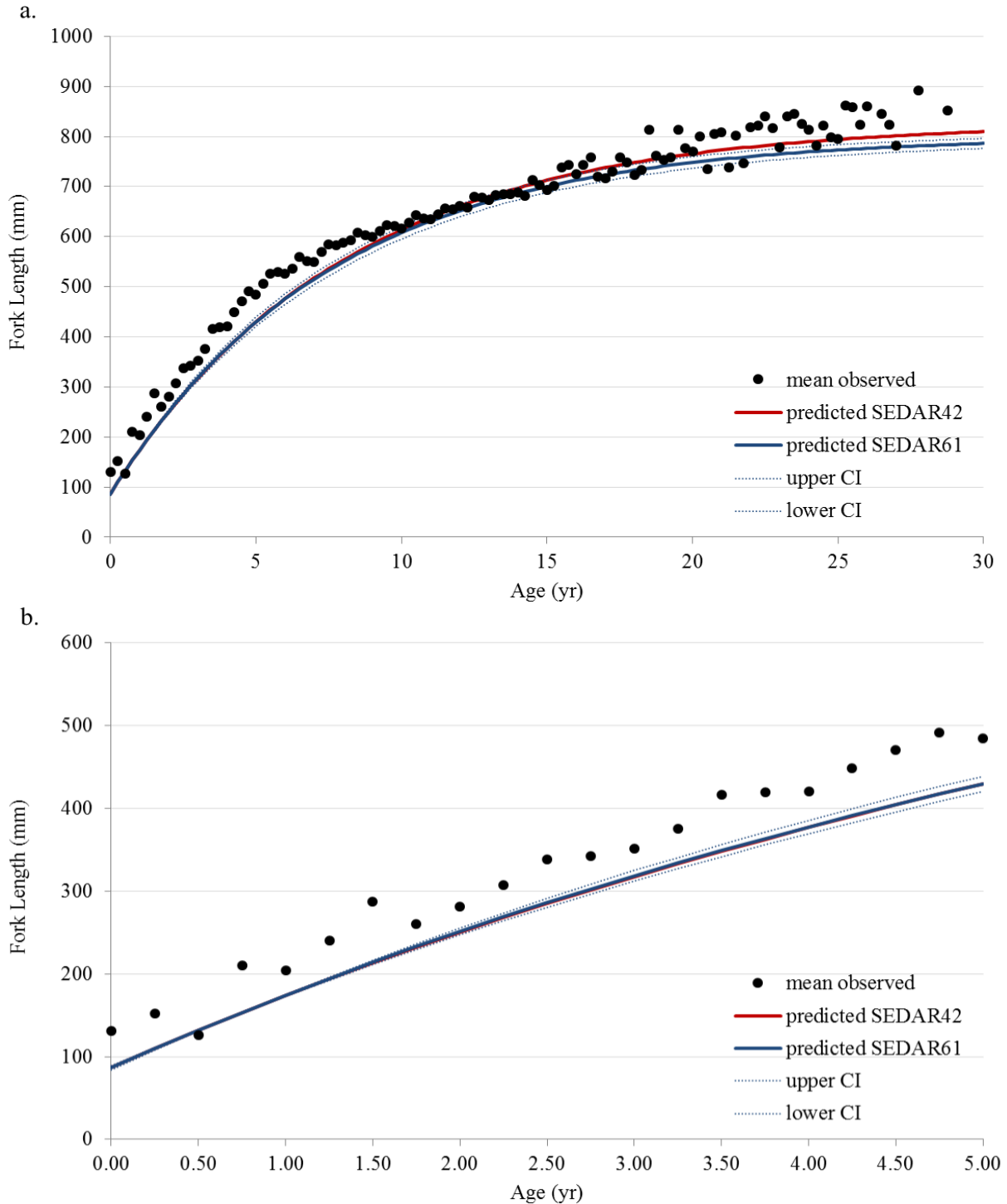
Year	N	N adj	50	52	54	56	58	60	62	64	66	68	70	72	74	76	78	80	82	84	86	88	90	92	94	96
2014	247	51.4	0.05	0.03	0.04	0.02	0.03	0.02	0.04	0.02	0.02	0.02	0.01	0.01	0.00	0.01	0.00	0.00	0.00	0.00	0.00	0.00	0.00	0.00	0.00	0.00
2015	106	32.1	0.03	0.06	0.04	0.05	0.02	0.04	0.06	0.06	0.02	0.03	0.02	0.03	0.00	0.02	0.00	0.00	0.00	0.00	0.01	0.00	0.00	0.00	0.00	0.00
2016	143	38.5	0.03	0.01	0.02	0.03	0.03	0.03	0.03	0.03	0.02	0.02	0.02	0.03	0.01	0.01	0.01	0.00	0.00	0.00	0.00	0.00	0.00	0.00	0.00	0.00
2017	58	25.7	0.00	0.02	0.03	0.00	0.03	0.00	0.00	0.05	0.00	0.00	0.00	0.00	0.00	0.02	0.00	0.00	0.00	0.00	0.00	0.00	0.00	0.00	0.00	0.00



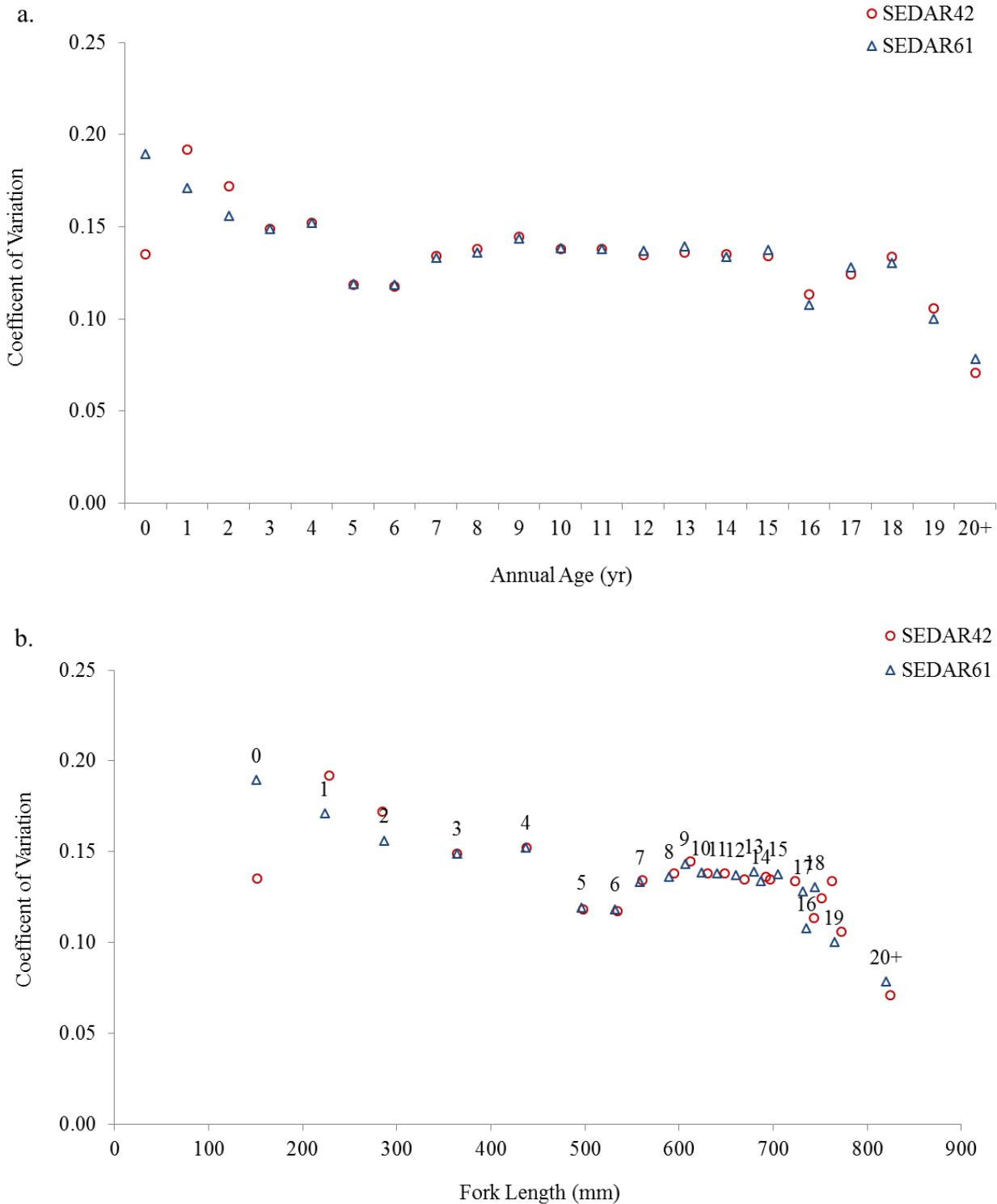
2.10 Figures



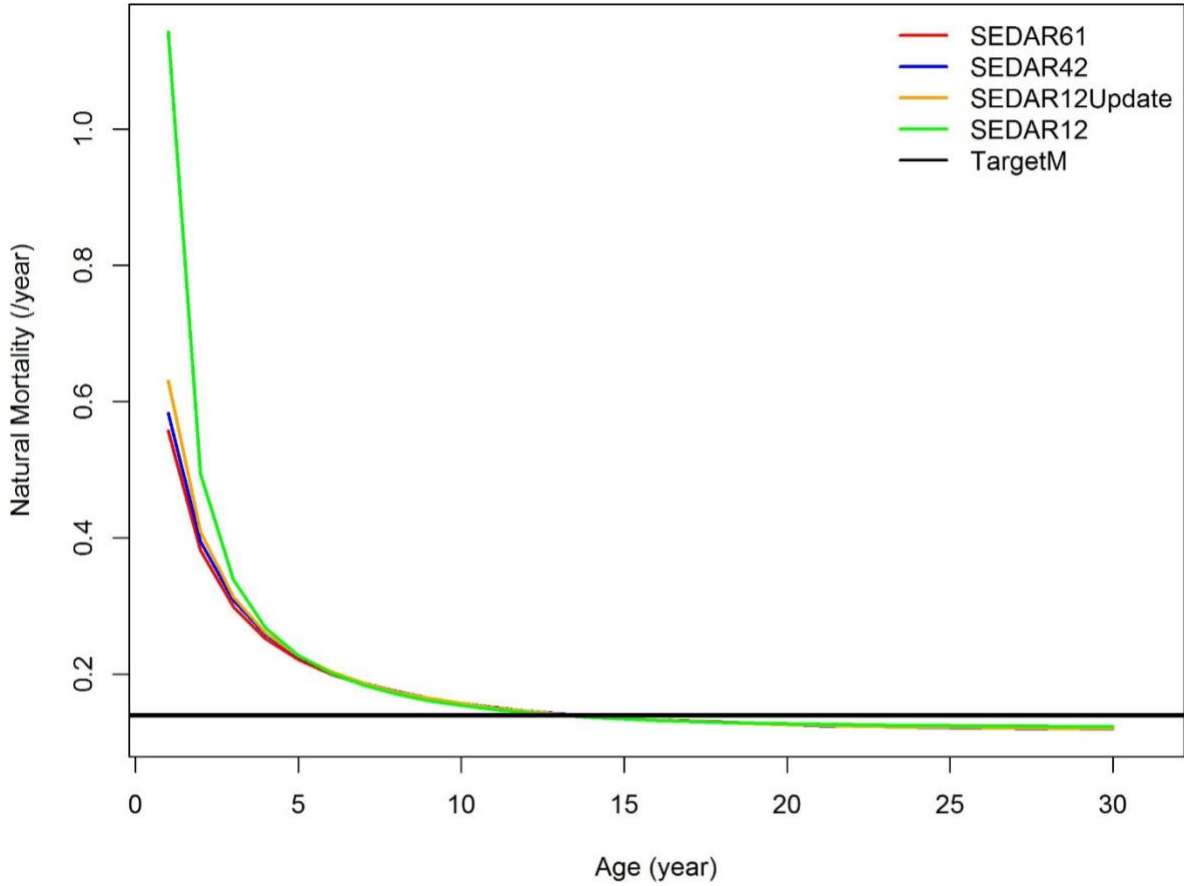
**Figure 2.1.** Gulf of Mexico Fisheries Management Region consisting of NMFS Shrimp Statistical Zones 1 (easternmost) through 21 (westernmost) and close-up of the southern boundary as defined by the Gulf of Mexico/South Atlantic Council boundary.



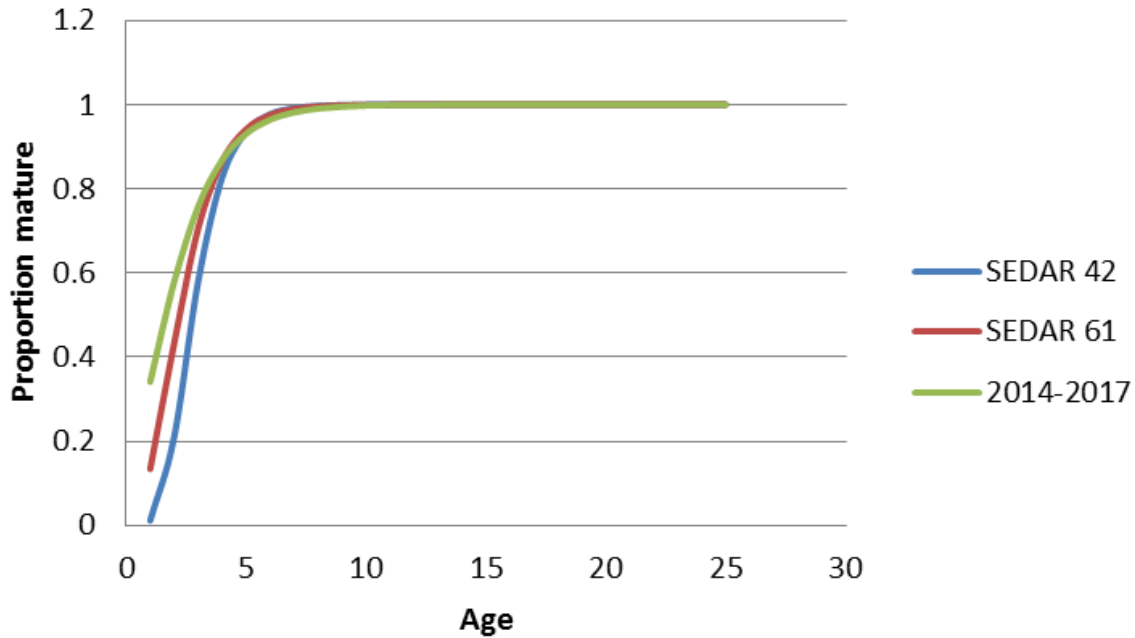
**Figure 2.2.** Results of the size-modified von Bertalanffy growth model with coefficient of variation increase linearly with length variance structure for Red Grouper from the Gulf of Mexico (1991-2017) for (a) mean fractional ages 0-29 and for (b) mean fractional ages 0-5 ± standard deviation. SEDAR61 observed mean size-at-age (black circles), estimated size-at-age (blue line), and estimated 95% confidence intervals (blue dashed line). SEDAR42 estimate size-at-age (red line) provided for comparison.



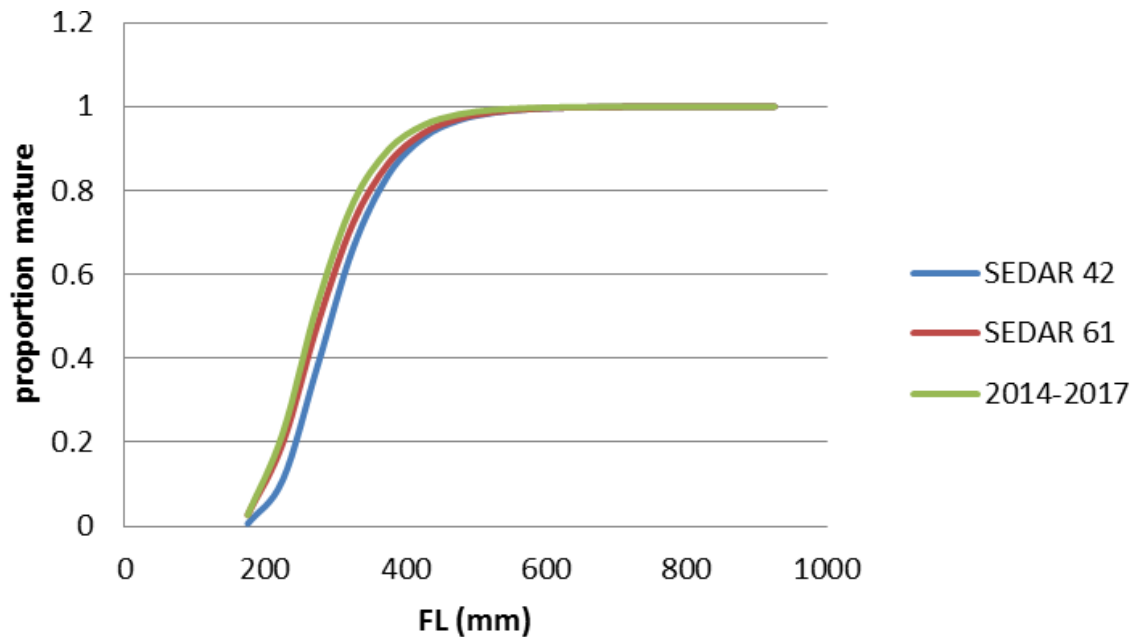
**Figure 2.3.** Comparison of variance structure for observed size-at-age data for Red Grouper from the northeastern Gulf of Mexico from SEDAR42 (N = 38,813) and previous and new data for SEDAR61 (N = 47,680) (a) coefficient of variation (standard deviation / mean) for each age group and (b) coefficient of variation (standard deviation / mean) at mean length for each age group (numbered; plus group: ages 20-29). Sample sizes provided in **Table 2.3**.



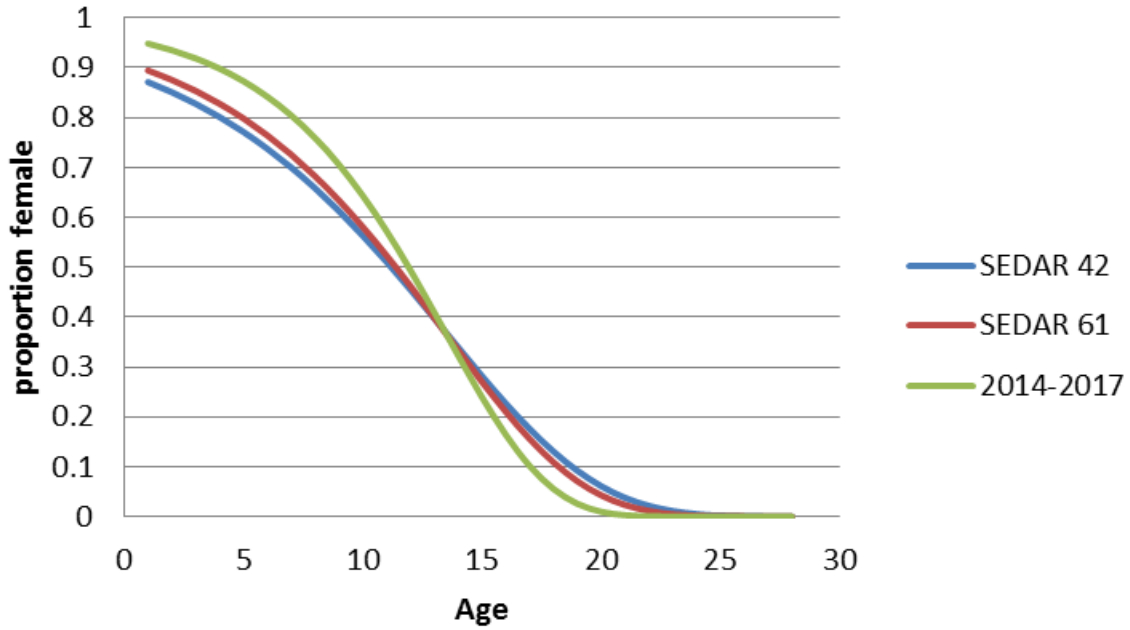
**Figure 2.4.** Comparison of age-specific natural mortality (M) vectors for Red Grouper from the northeastern Gulf of Mexico. Each vector was calculated using the same regression (Lorenzen 2005), age 5 as the first age at vulnerability, and a target M of 0.14 (Hoenig<sub>teleost</sub>, maximum age of 29 years; thick black line). The only difference among the age-specific natural mortality vectors was the predicted von Bertalanffy growth parameters used in the estimations.



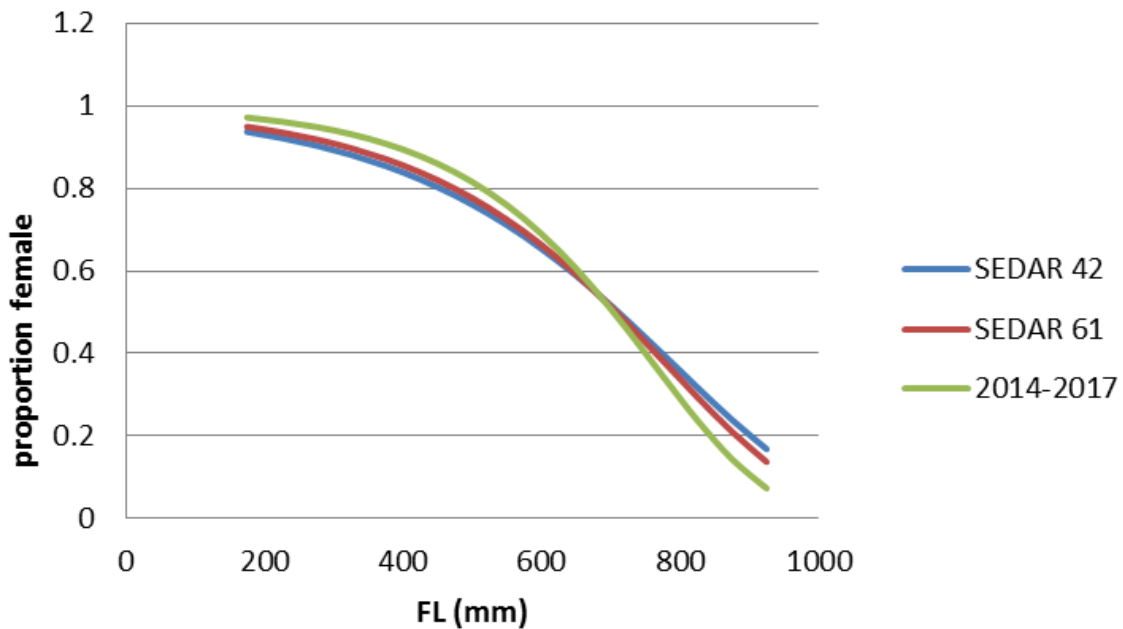
**Figure 2.5.** Comparison of logistic fits of age at maturity for Red Grouper between the estimates from SEDAR42 (N = 1,559, A50 maturity = 2.8 years) and SEDAR61 (N = 2,069, A50 maturity = 2.2 years). Data for SEDAR61 included data collected between 2014 and 2017 by NMFS Panama City and the FWRI.



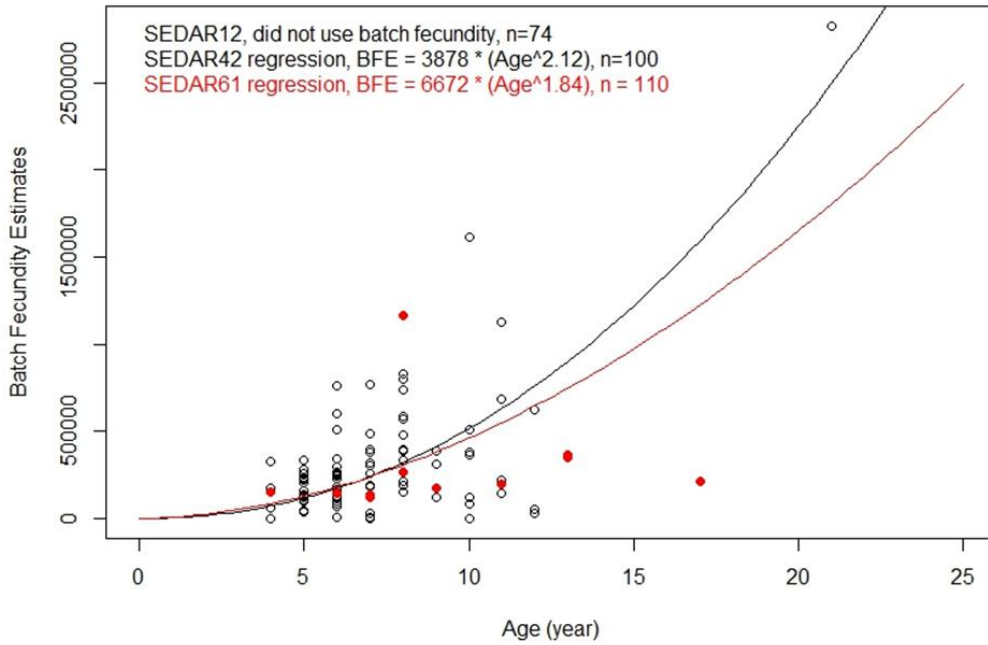
**Figure 2.6.** Comparison of logistic fits of length at maturity for Red Grouper between the estimates from SEDAR42 (N = 1,677, L50 maturity = 292 mm FL) and SEDAR61 (N = 2,189, L50 maturity = 278 mm FL). Data for SEDAR61 included data collected between 2014 and 2017 by NMFS Panama City and the FWRI.



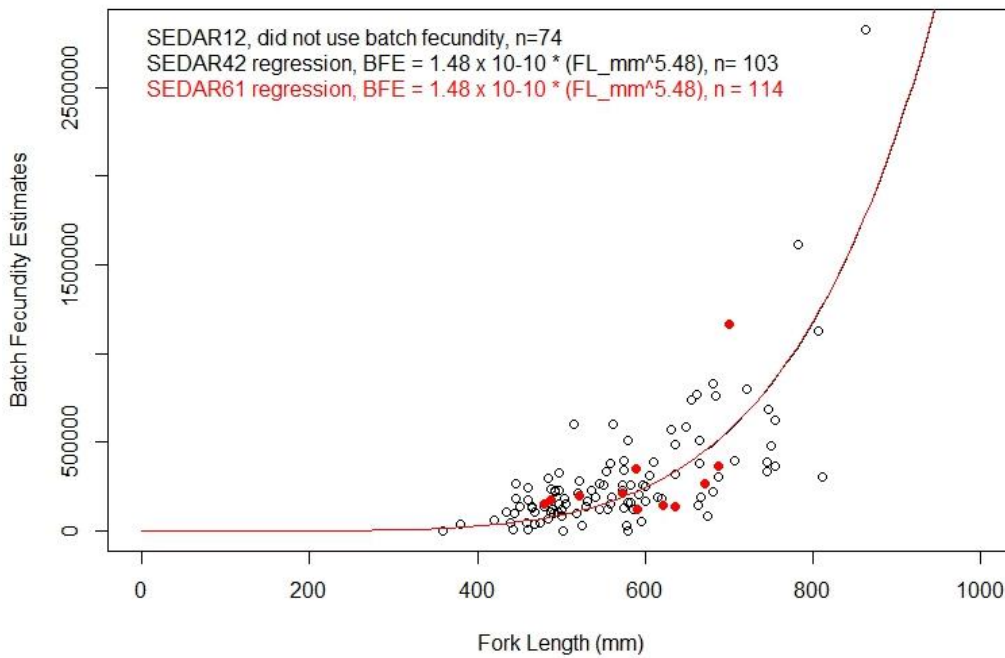
**Figure 2.7.** Comparison of logistic fits of age of sexual transition for Red Grouper between the estimates from SEDAR42 (N = 5,381, A50 transition = 11.2 years) and SEDAR61 (N = 7,296, A50 transition = 11.4 years). Data for SEDAR61 included data collected between 2014 and 2017 by NMFS Panama City and the FWRI.



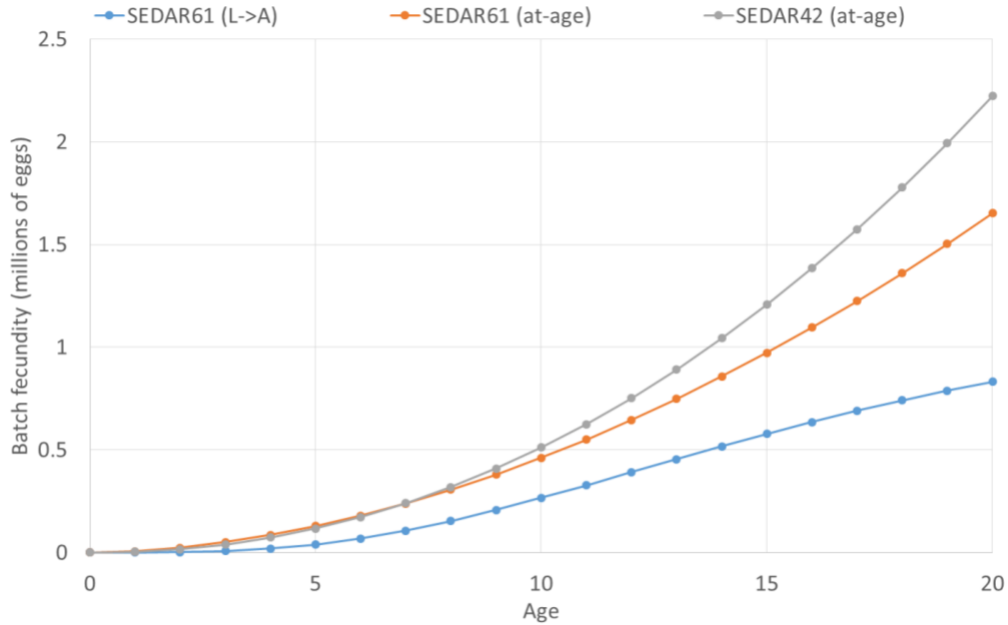
**Figure 2.8.** Comparison of logistic fits of length at sexual transition for Red Grouper between the estimates from SEDAR42 (N = 5,775, L50 transition = 707 mm FL) and SEDAR61 (N = 7,766, L50 transition = 708 mm FL). Data for SEDAR61 included data collected between 2014 and 2017 by NMFS Panama City and the FWRI.



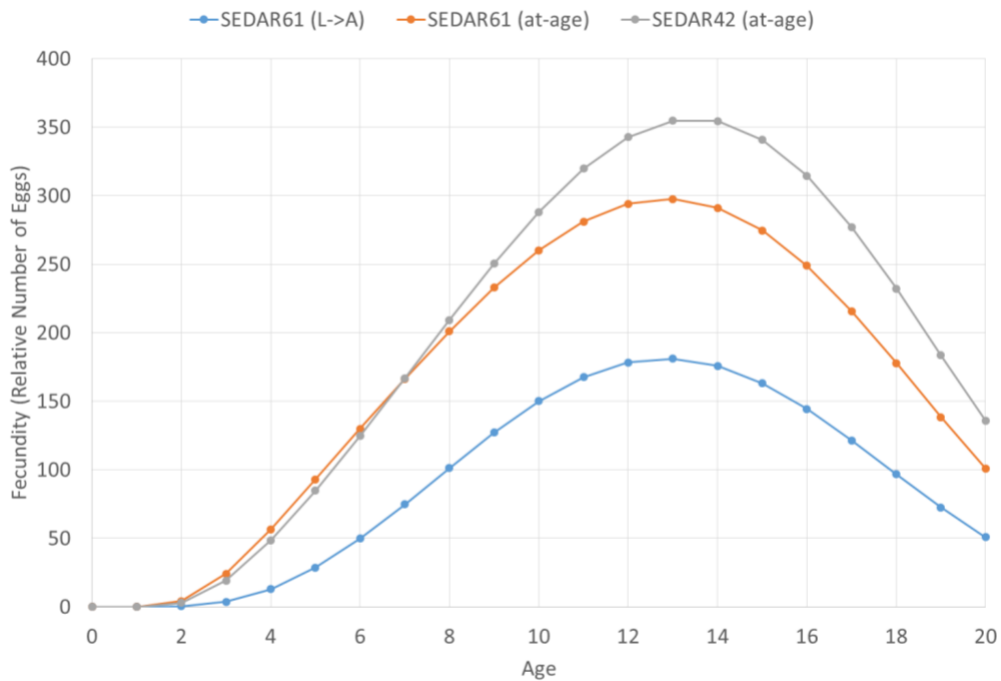
**Figure 2.9.** Batch fecundity by age for Red Grouper. Ten new samples were obtained for SEDAR61 between 2014 and 2017 by NMFS Panama City.



**Figure 2.10.** Batch fecundity by fork length for Red Grouper. Eleven new samples were obtained for SEDAR61 between 2014 and 2017 by NMFS Panama City.

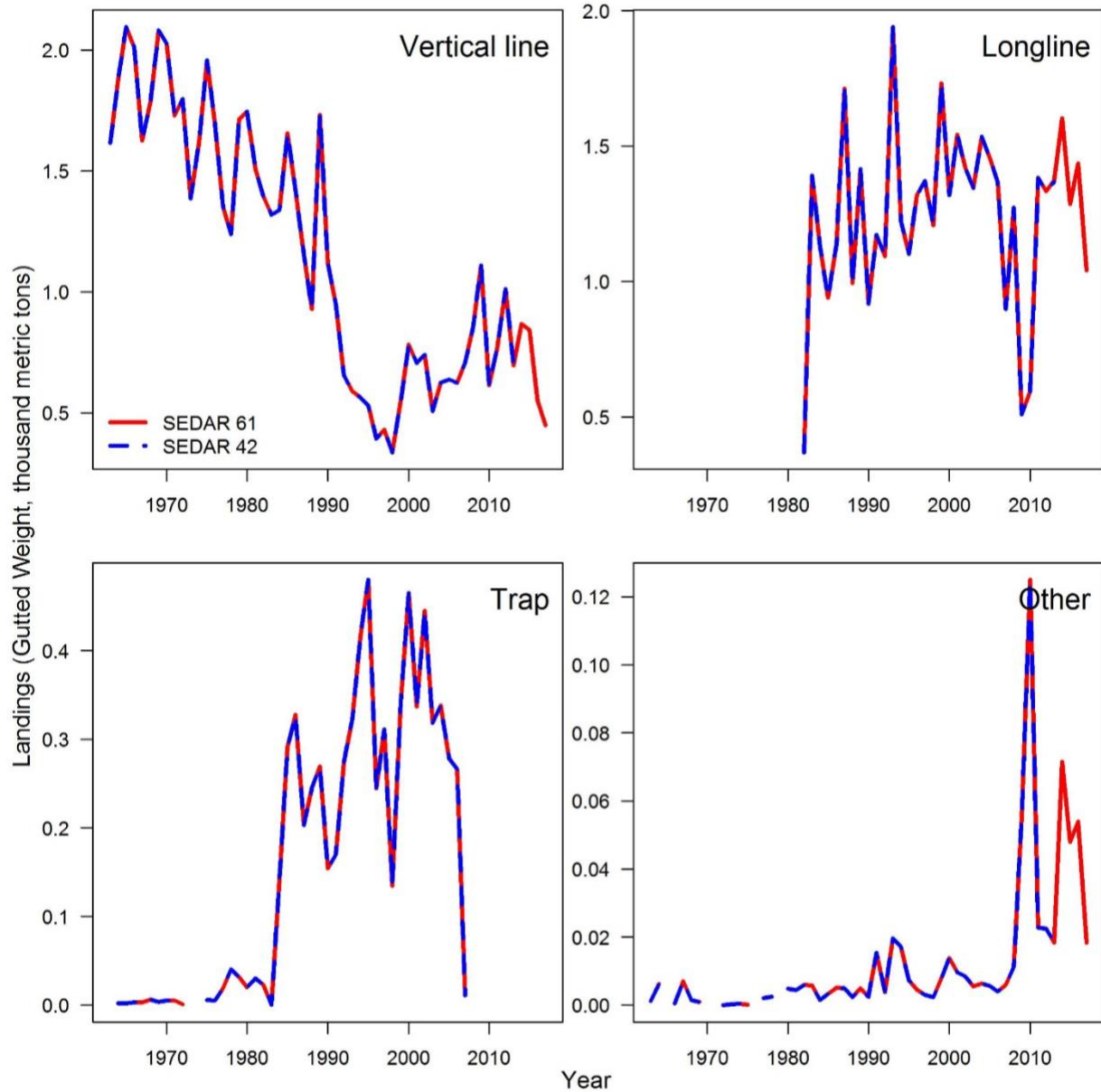


**Figure 2.11.** Comparison of batch fecundity-at-age for Red Grouper. The blue line reflects the recommended conversion of fecundity-at-length to fecundity-at-age using the growth curve for SEDAR61.

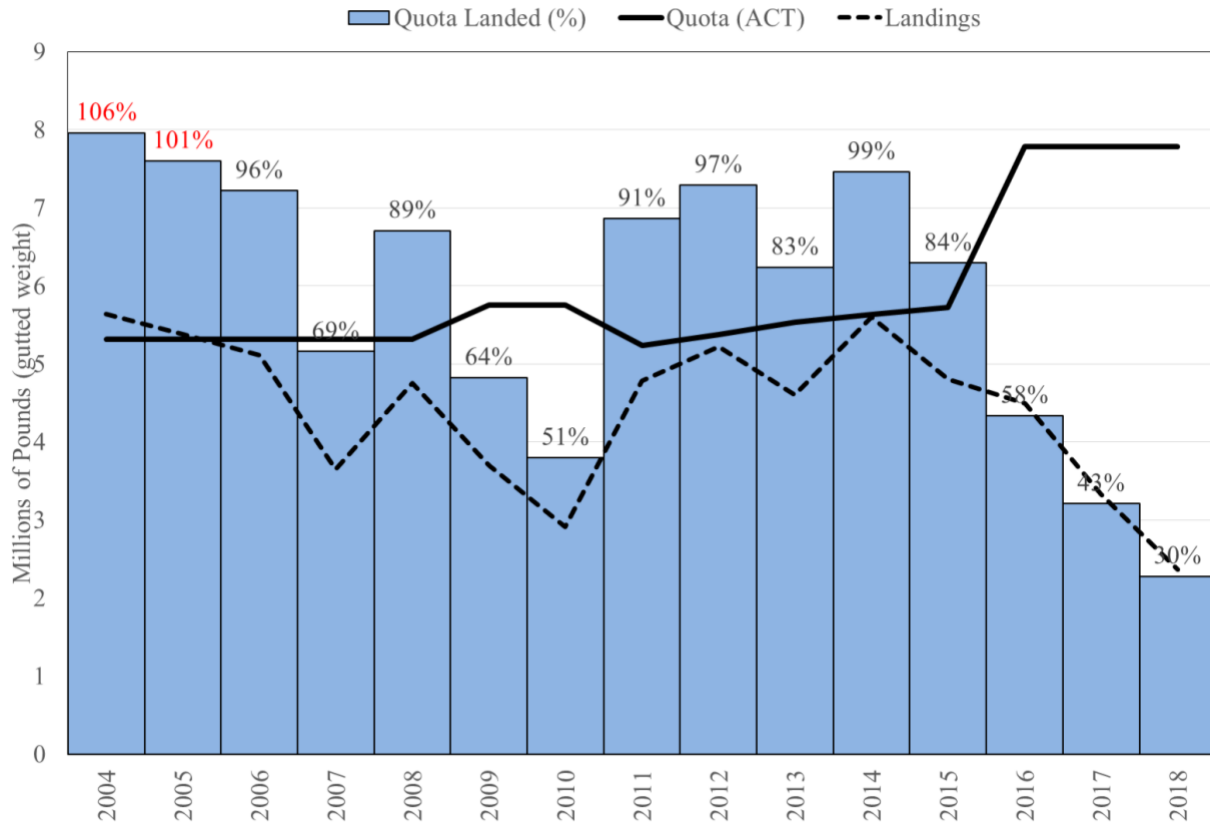


**Figure 2.12.** Comparison of annual fecundity-at-age vectors for Red Grouper that take into account transition from female to male at older ages. The blue line reflects the recommended fecundity vector based on converting fecundity-at-length to fecundity-at-age using the growth curve for SEDAR61.

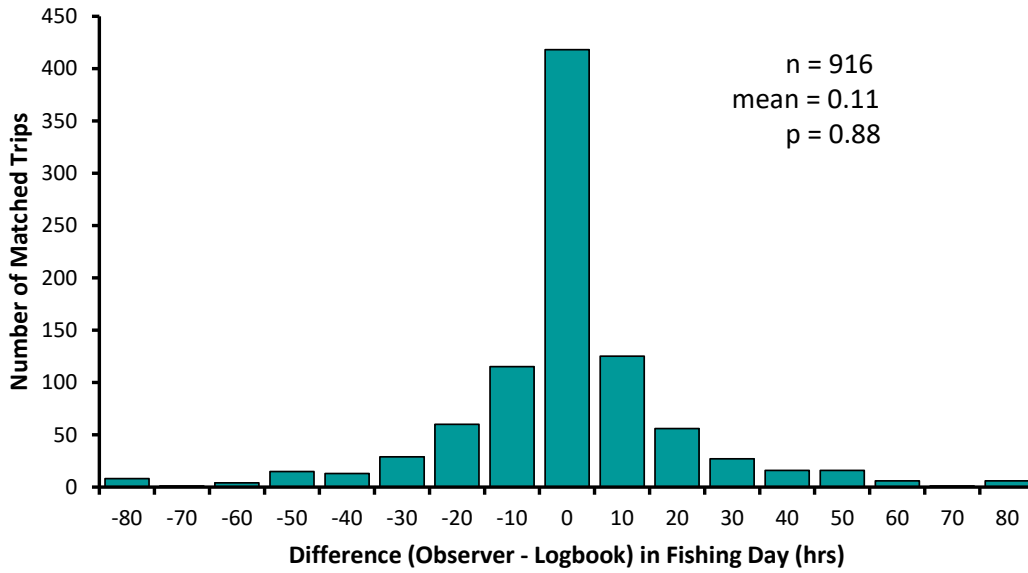




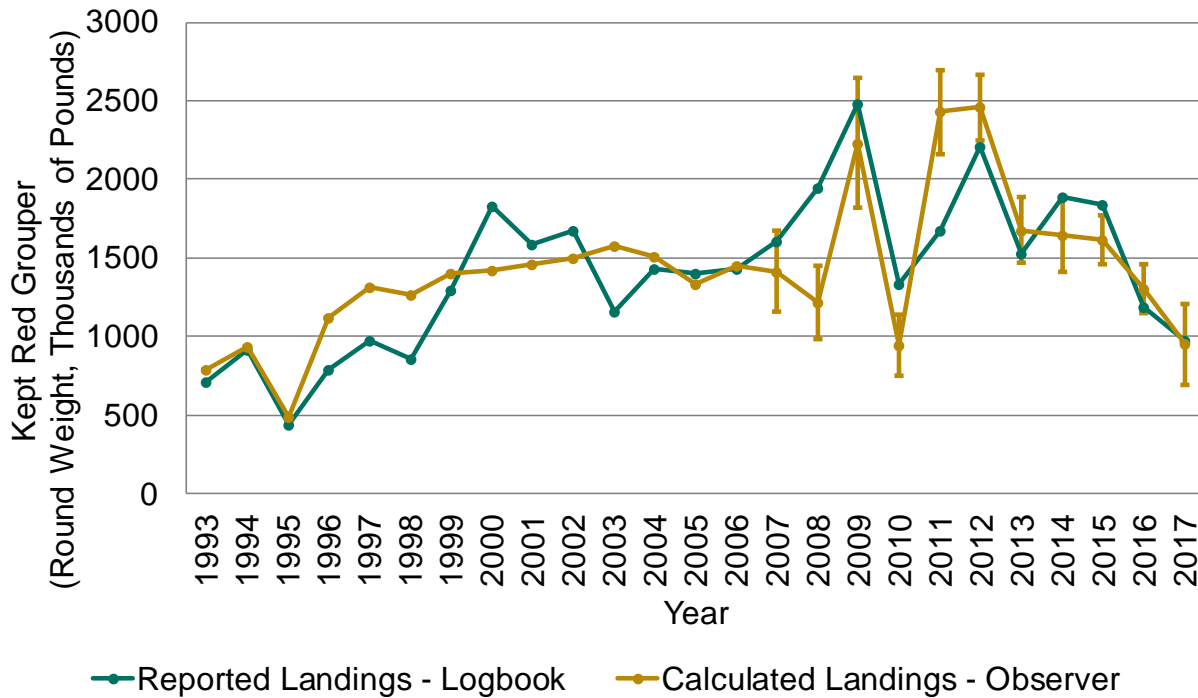
**Figure 2.13.** Commercial landings (guttled weight in thousands of metric tons) for the vertical line, longline, trap, and other fleets in the U.S. Gulf of Mexico. Note that the start year of the SEDAR61 Base Model is 1986.



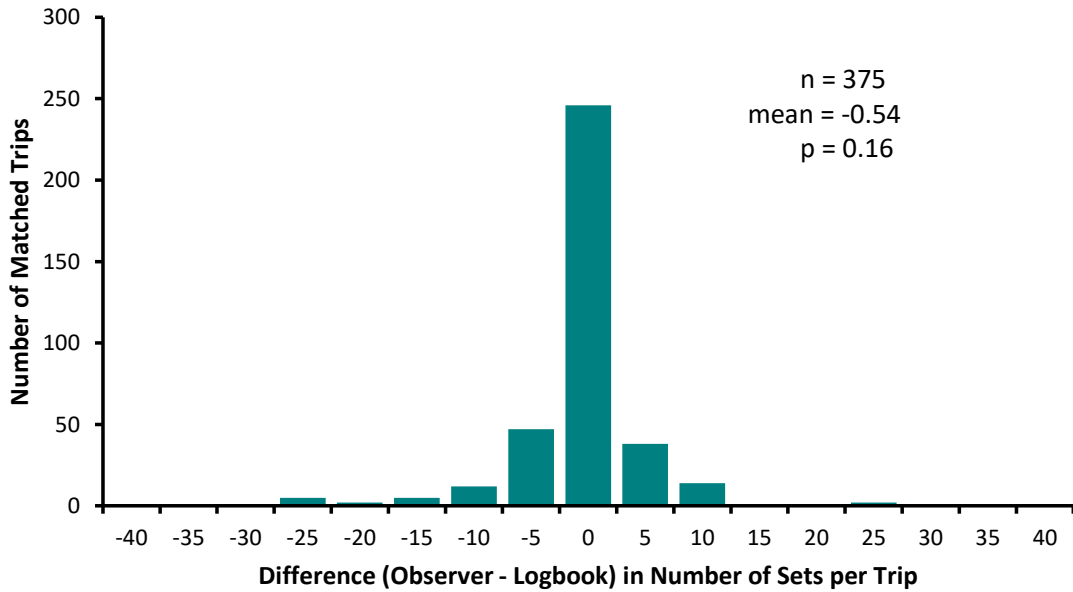
**Figure 2.14.** Time series of commercial landings (dashed line) and quota (thick line) for Red Grouper in the Gulf of Mexico, with preliminary 2018 estimates. Bars represent the percent of quota landed, with red values indicative of commercial closures due to the quota being exceeded. Data from 2010 through 2018 were obtained from the Quotas and Catch Allowances, accessed March 7, 2019 (<https://portal.southeast.fisheries.noaa.gov/reports/cs/CommercialQuotasCatchAllowanceTable.pdf>). Data for the remaining years were obtained from the Gulf of Mexico Historical Commercial Landings and Annual Catch Limits (ACLs), updated November 7, 2018 ([https://sero.nmfs.noaa.gov/sustainable\\_fisheries/acl\\_monitoring/commercial\\_gulf/reef\\_fish\\_historical/gulf\\_commercial\\_historical.pdf](https://sero.nmfs.noaa.gov/sustainable_fisheries/acl_monitoring/commercial_gulf/reef_fish_historical/gulf_commercial_historical.pdf)).



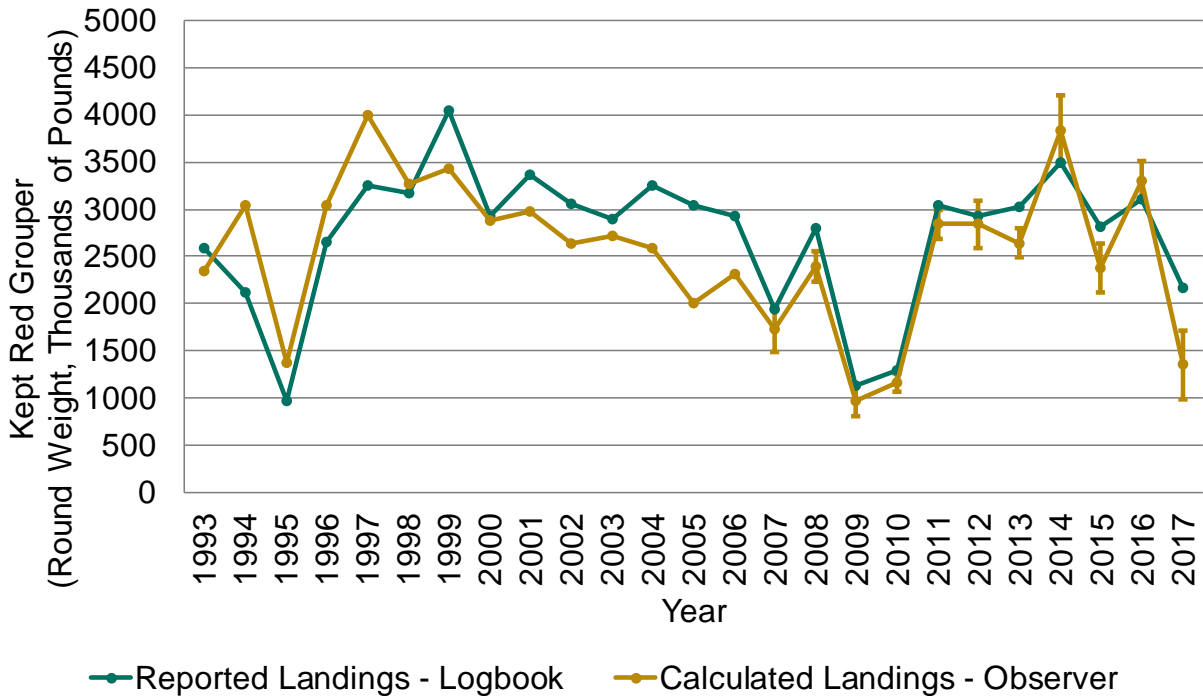
**Figure 2.15.** Frequency plot of the difference (observer – logbook) in fishing day hours for matched vertical line trips. The mean difference was not significantly different from zero.



**Figure 2.16.** Comparison of annual logbook landings of Red Grouper with CPUE-expansion estimates from observer vertical line data. Error bars (SE) are shown for observer estimates for 2007-2017, the time frame of the Gulf of Mexico coastal observer program.

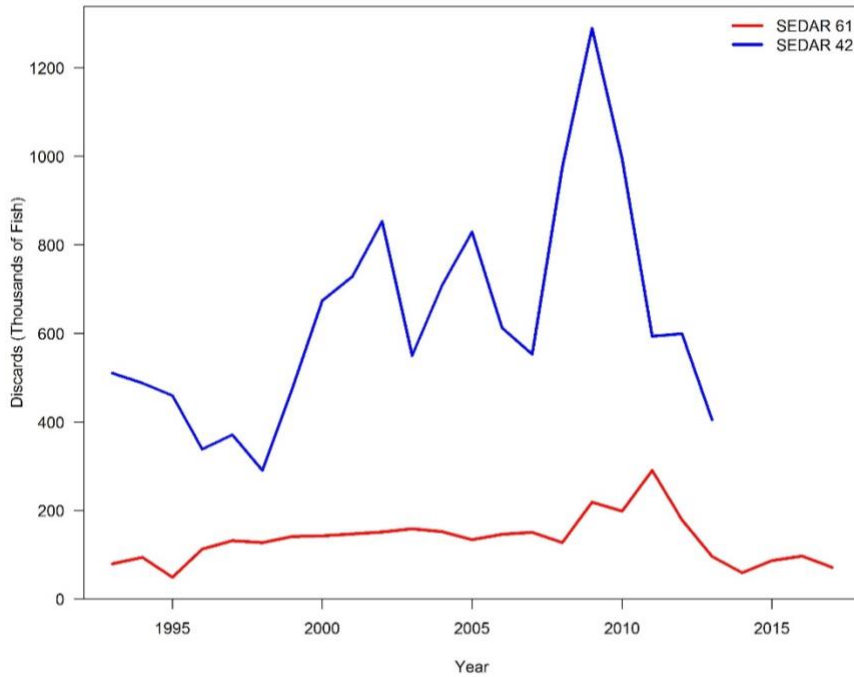


**Figure 2.17.** Frequency plot of the difference (observer – logbook) in number of sets per trip for matched bottom longline trips. The mean difference was not significantly different from zero.

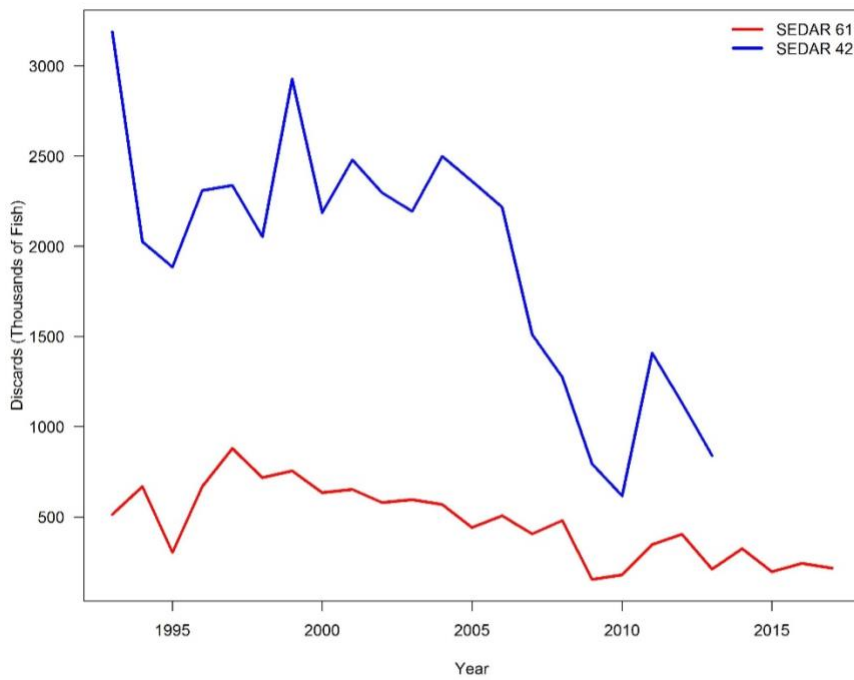


**Figure 2.18.** Comparison of annual logbook landings of Red Grouper with CPUE-expansion estimates from observer longline data. Error bars (SE) are shown for observer estimates for 2007-2017, the time frame of the Gulf of Mexico coastal observer program.

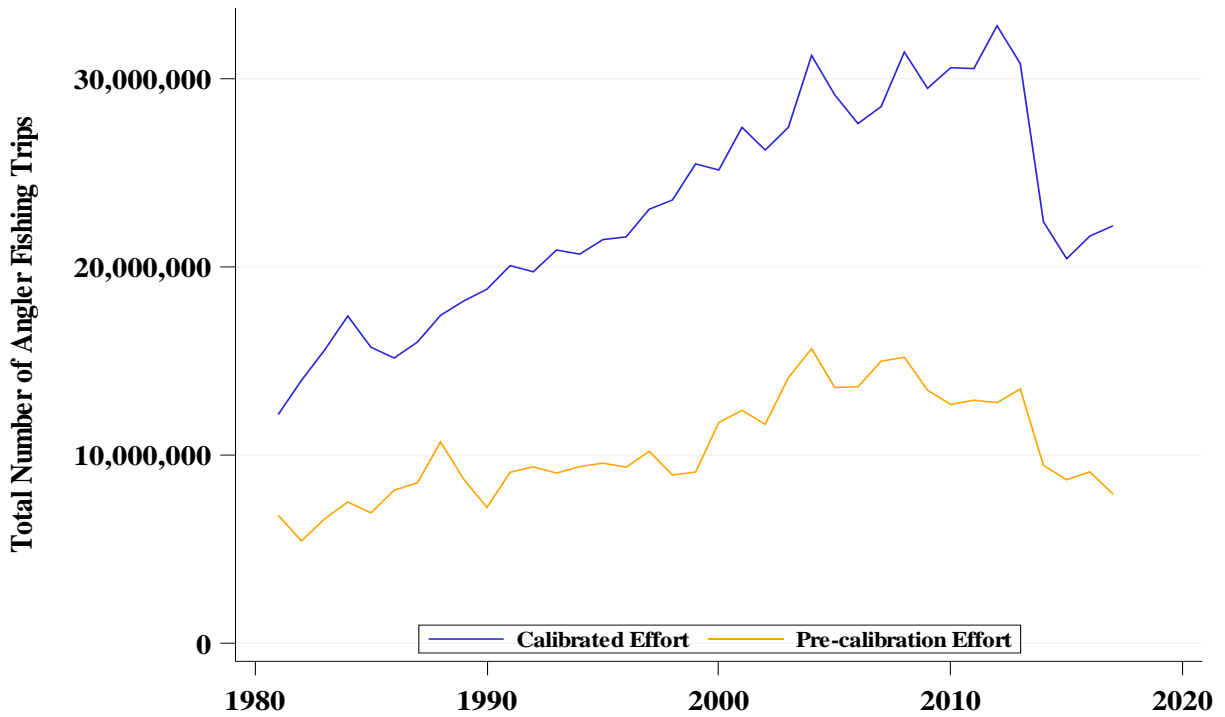
**A) Commercial vertical line**



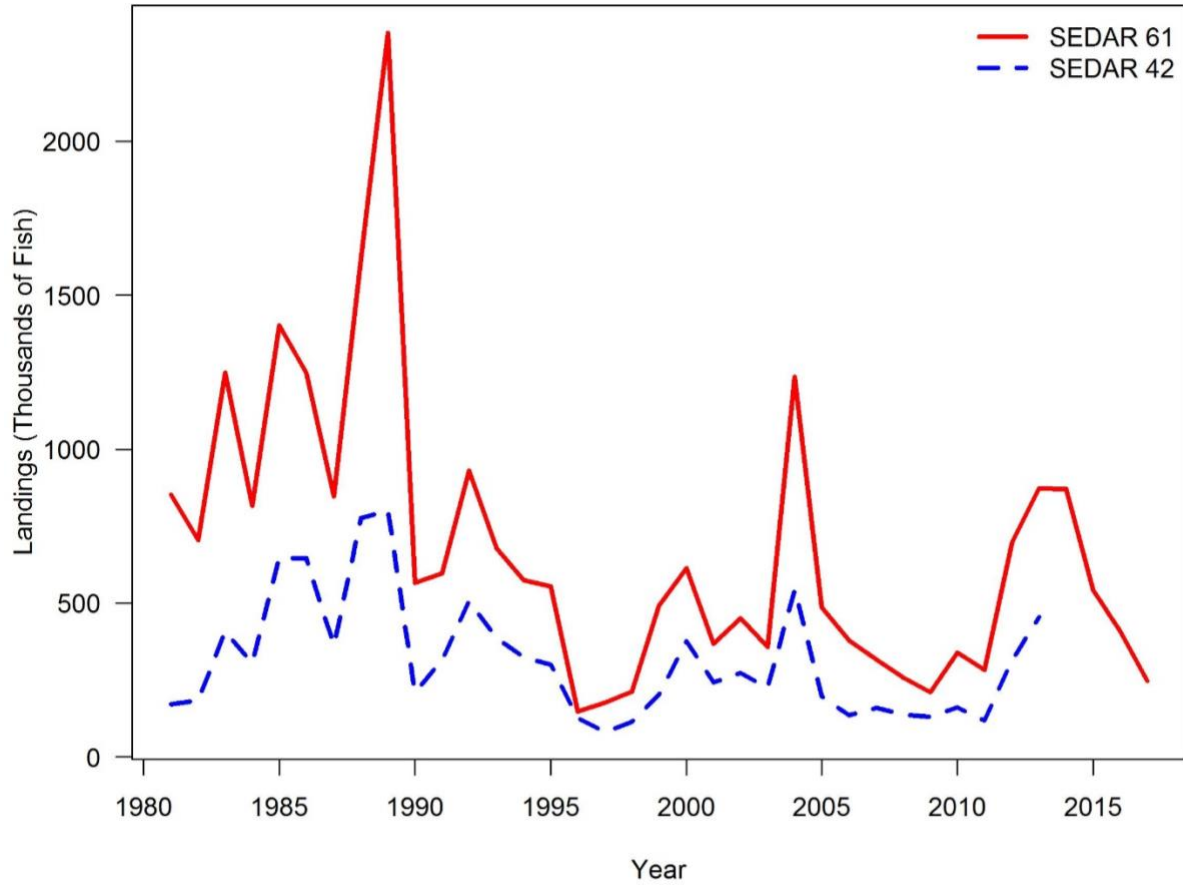
**B) Commercial longline**



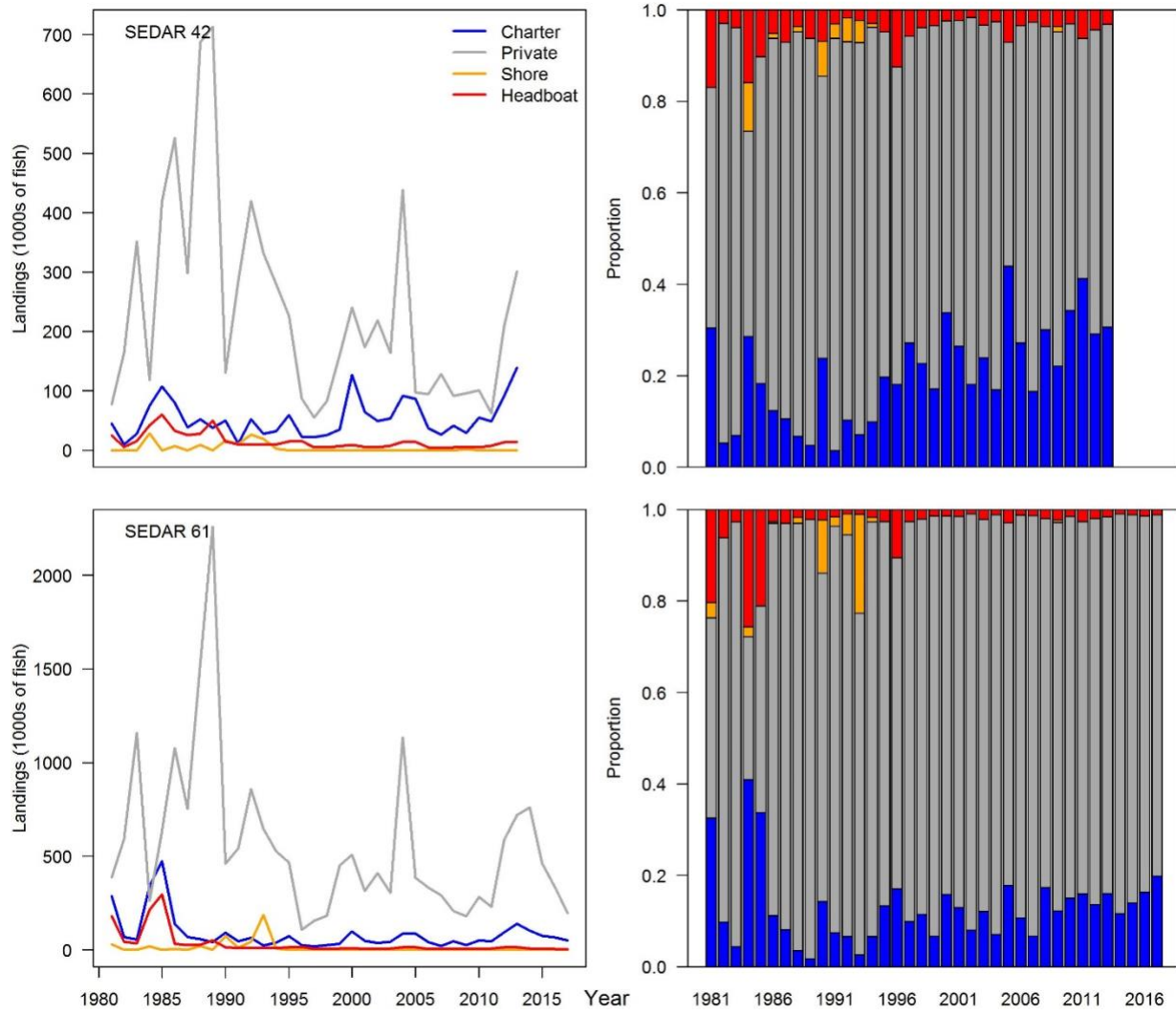
**Figure 2.19.** Final commercial discards based on SEDAR61 recommended methods for the commercial vertical line and longline fleets. Note that the previous discard approach used in SEDAR42 was not recreated for SEDAR61.



**Figure 2.20.** Comparison of the historical estimates of private boat angler fishing trips for the Gulf of Mexico region between the new calibrated estimates (blue line) and the uncalibrated estimates (orange line). Figure obtained from Marine Recreational Information Program transition presentation to the Gulf of Mexico Fishery Management Council Scientific and Statistical Committee (8a Briefing on MRIP Transition for GoM SSC 10-2-18.pdf).

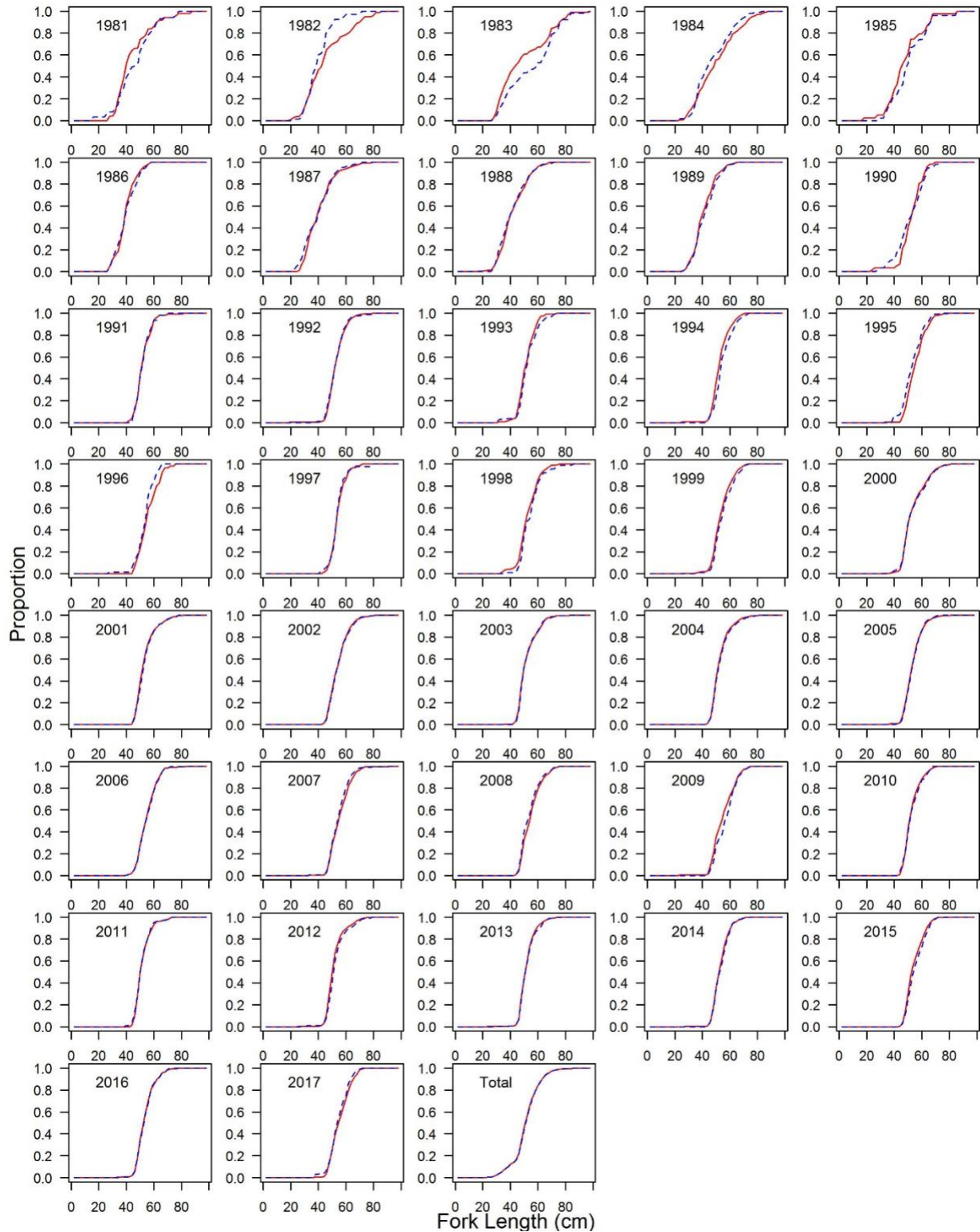


**Figure 2.21.** Recreational landings (thousands of fish) for the recreational fishery. Note that the start year for the SEDAR61 Base Model is 1986.

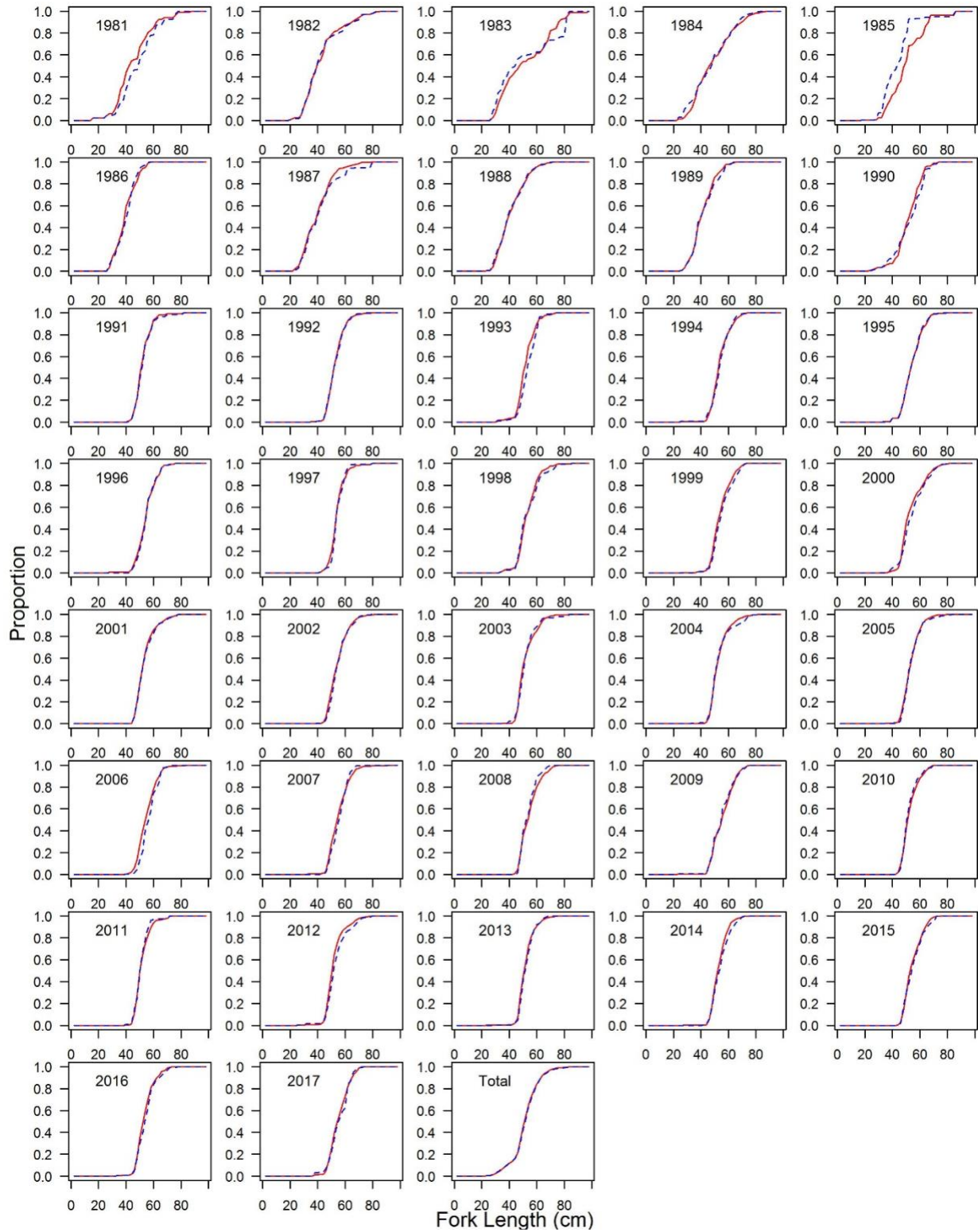


**Figure 2.22.** Comparison of recreational landings of Red Grouper by mode provided during SEDAR42 (top panels) and SEDAR61 (bottom panels).

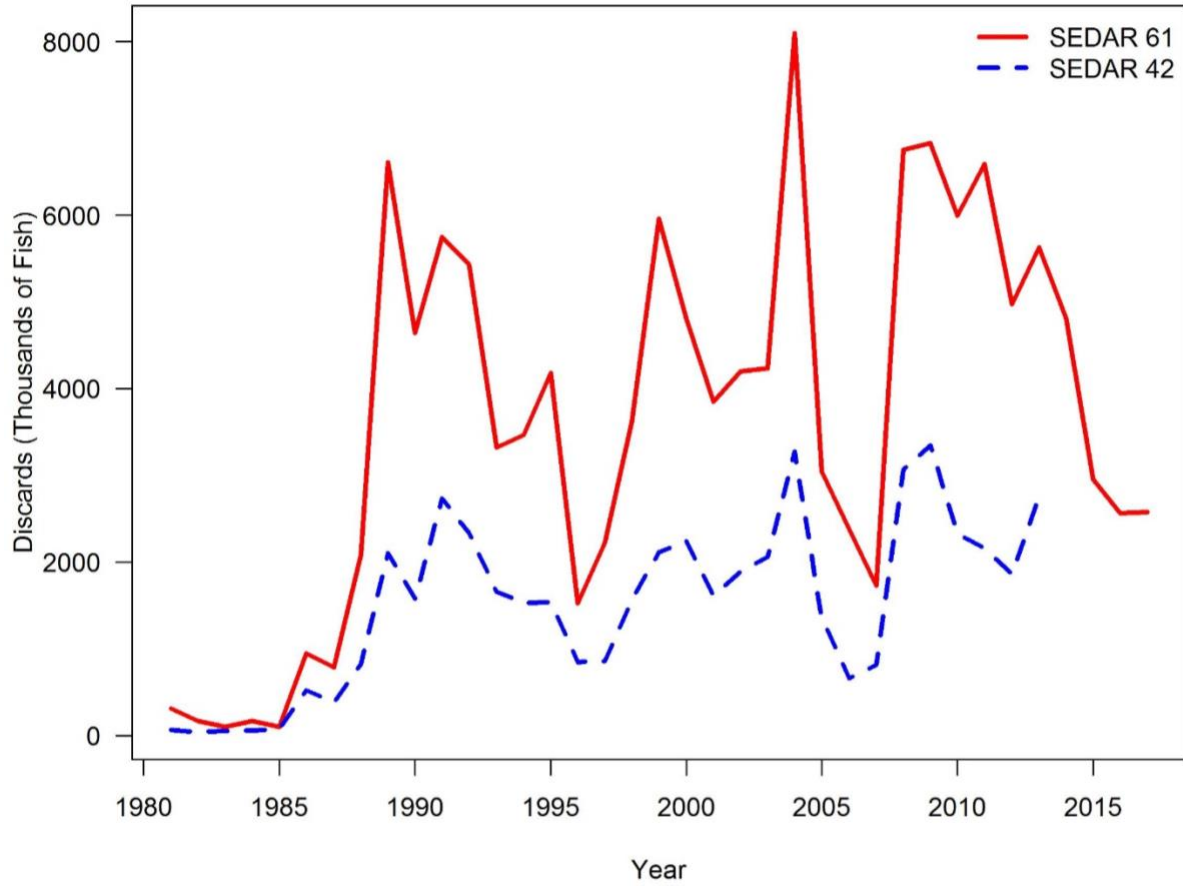




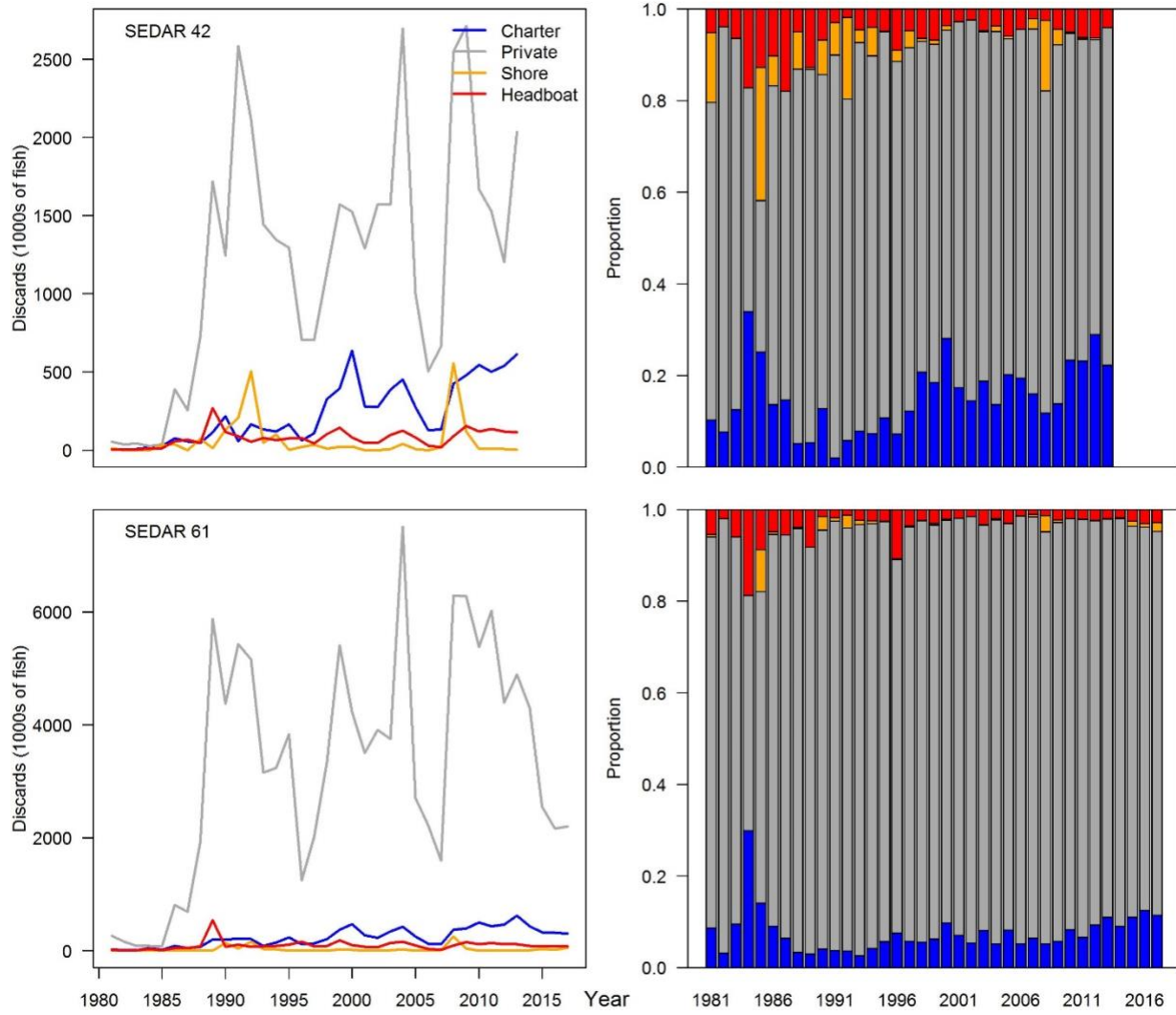
**Figure 2.23.** Comparison of cumulative length distributions for Red Grouper derived from observed only MRIP lengths (observed; solid red line) and imputed only MRIP lengths (imputed; blue dashed line).



**Figure 2.24.** Comparison of cumulative length distributions for Red Grouper derived from all MRIP length data combined without sample weights (unweighted; solid red line) and with sample weights (weighted; blue dashed line).

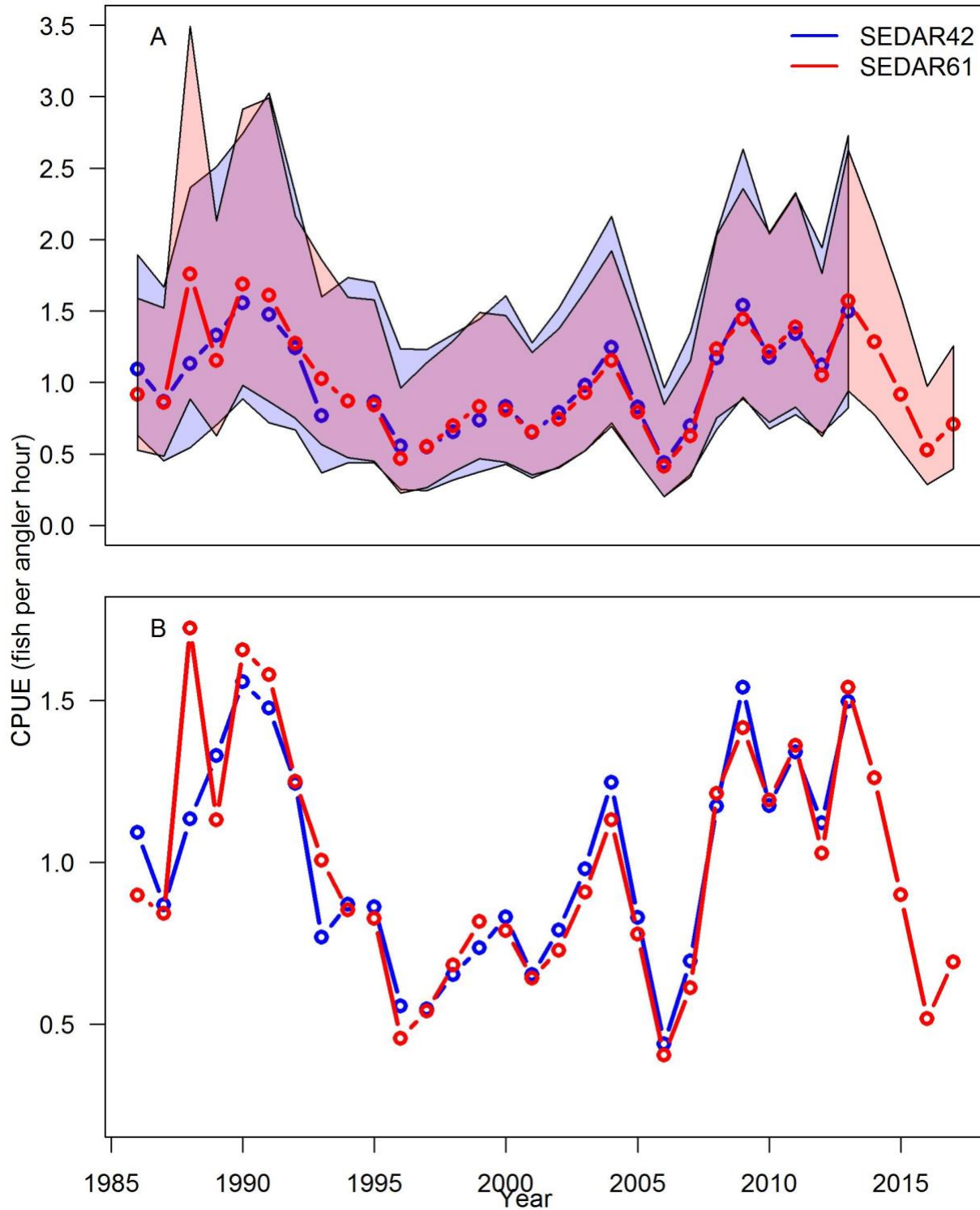


**Figure 2.25.** Recreational discards of Red Grouper for the recreational fishery. Note that the start year for the SEDAR61 Base Model is 1986.

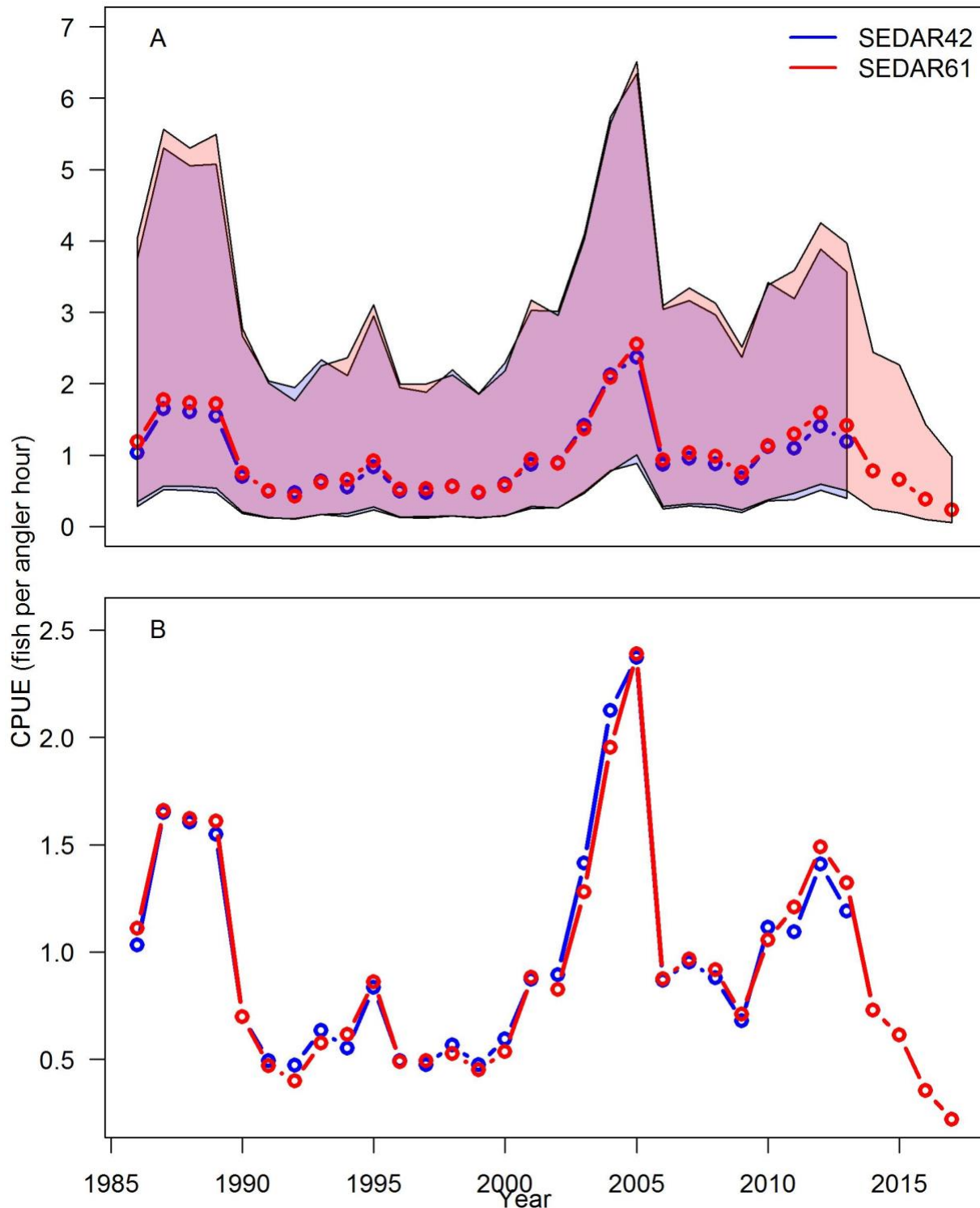


**Figure 2.26.** Comparison of recreational discards of Red Grouper by mode provided during SEDAR42 (top panels) and SEDAR61 (bottom panels).

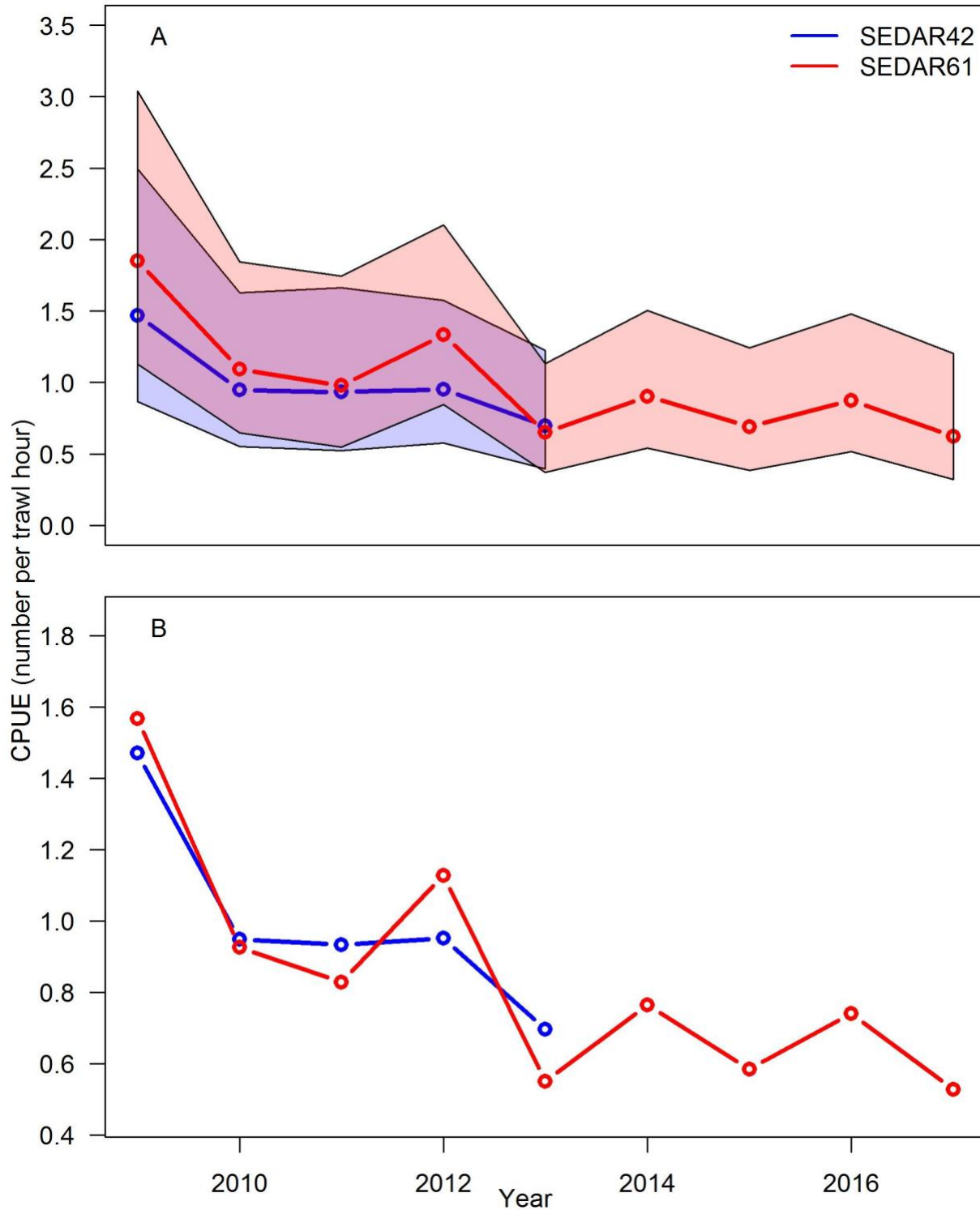




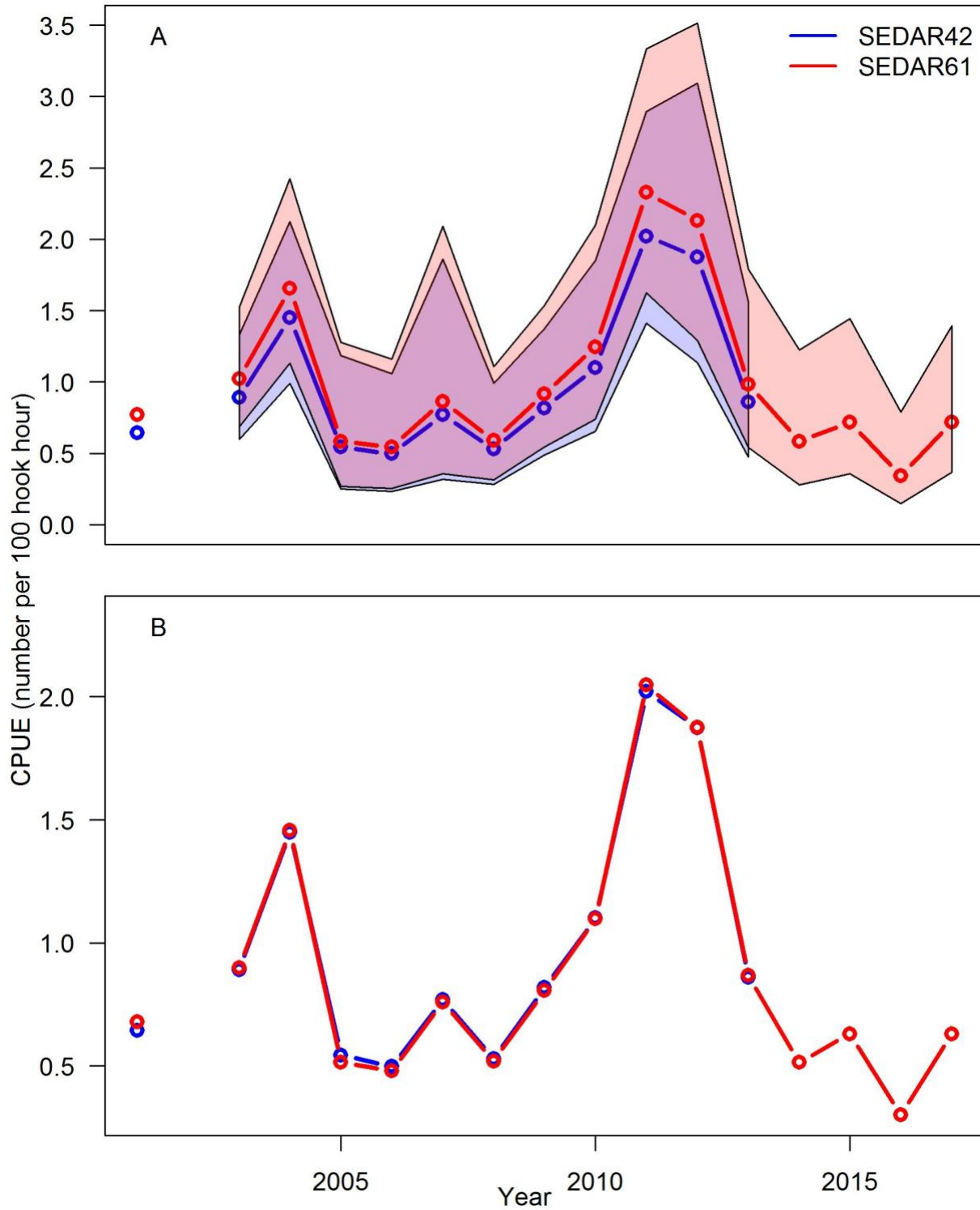
**Figure 2.27.** Index of relative abundance derived from the Marine Recreational Information Program Survey for the charter and private fishing modes. (A) Comparison of standardized indices for SEDAR61 and SEDAR42 with 95% confidence intervals (shaded). (B) SEDAR61 and SEDAR42 indices have been normalized by their respective means.



**Figure 2.28.** Index of relative abundance derived from the Southeast Region Headboat survey. (A) Comparison of standardized indices for SEDAR61 and SEDAR42 with 95% confidence intervals (shaded). (B) SEDAR61 and SEDAR42 indices have been normalized by their respective means.

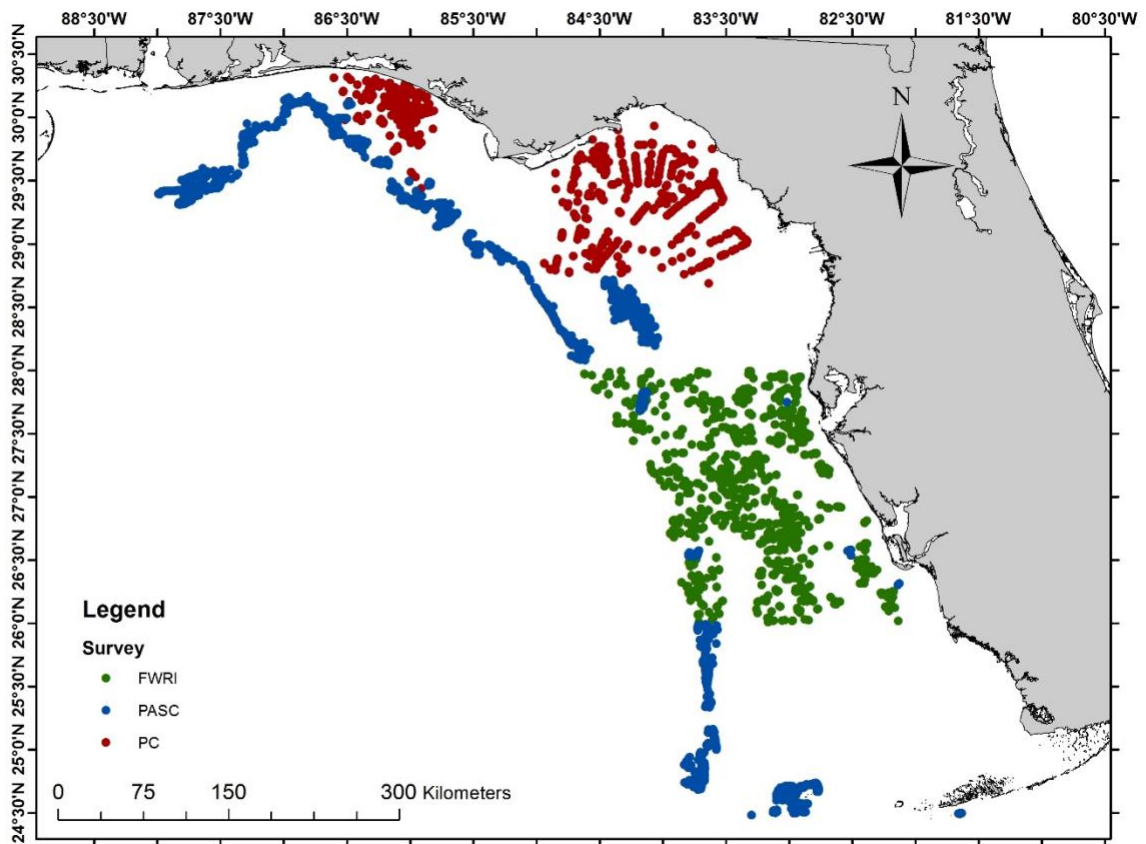


**Figure 2.29.** Index of relative abundance derived from the SEAMAP Summer Groundfish Survey. (A) Comparison of standardized indices for SEDAR61 and SEDAR42 with 95% confidence intervals (shaded). (B) SEDAR61 and SEDAR42 have been normalized by their respective means.

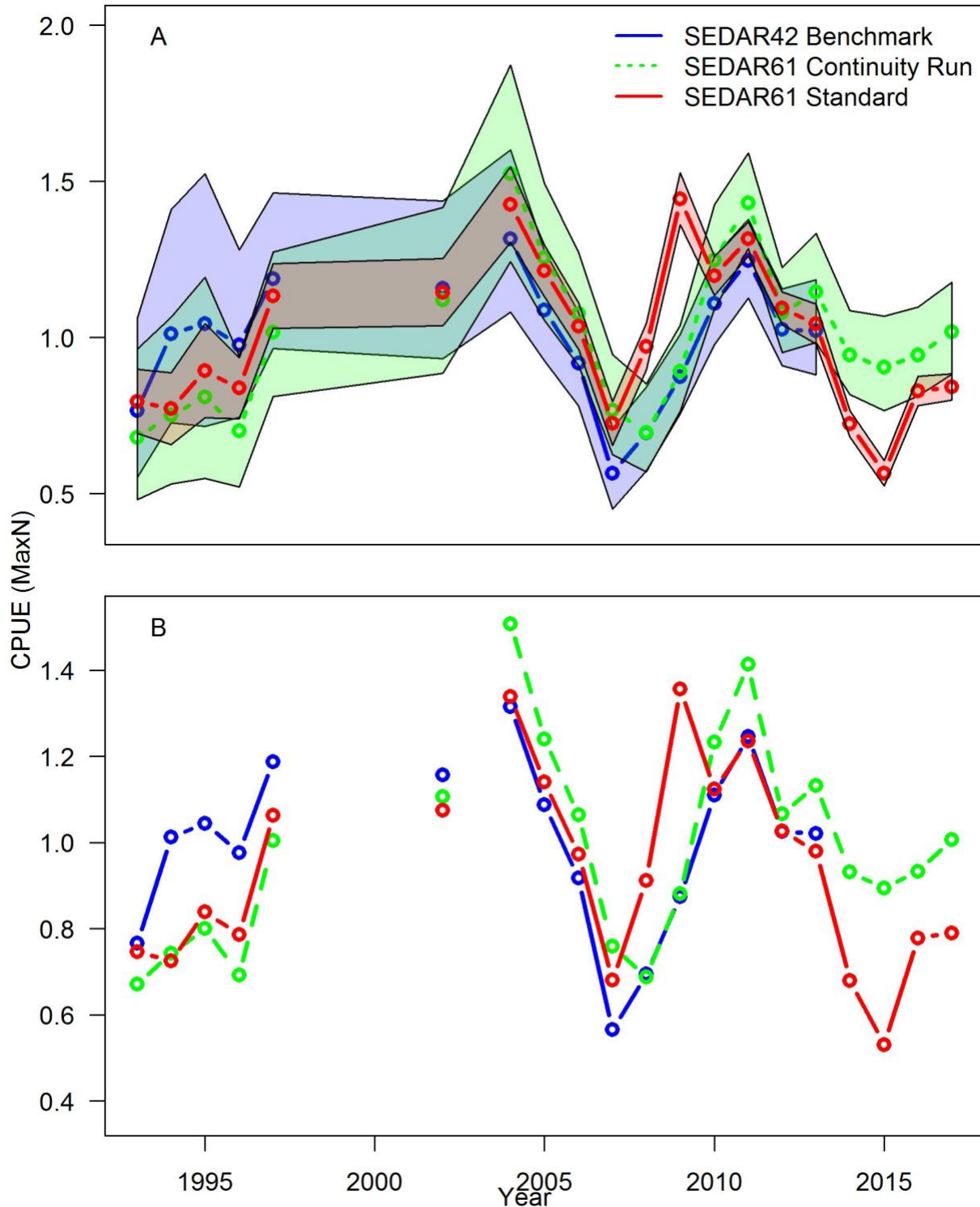


**Figure 2.30.** Index of relative abundance derived from the NMFS Bottom Longline Survey (A) Comparison of standardized indices for SEDAR61 and SEDAR42 with 95% confidence intervals (shaded). (B) SEDAR61 and SEDAR42 have been normalized by their respective means.

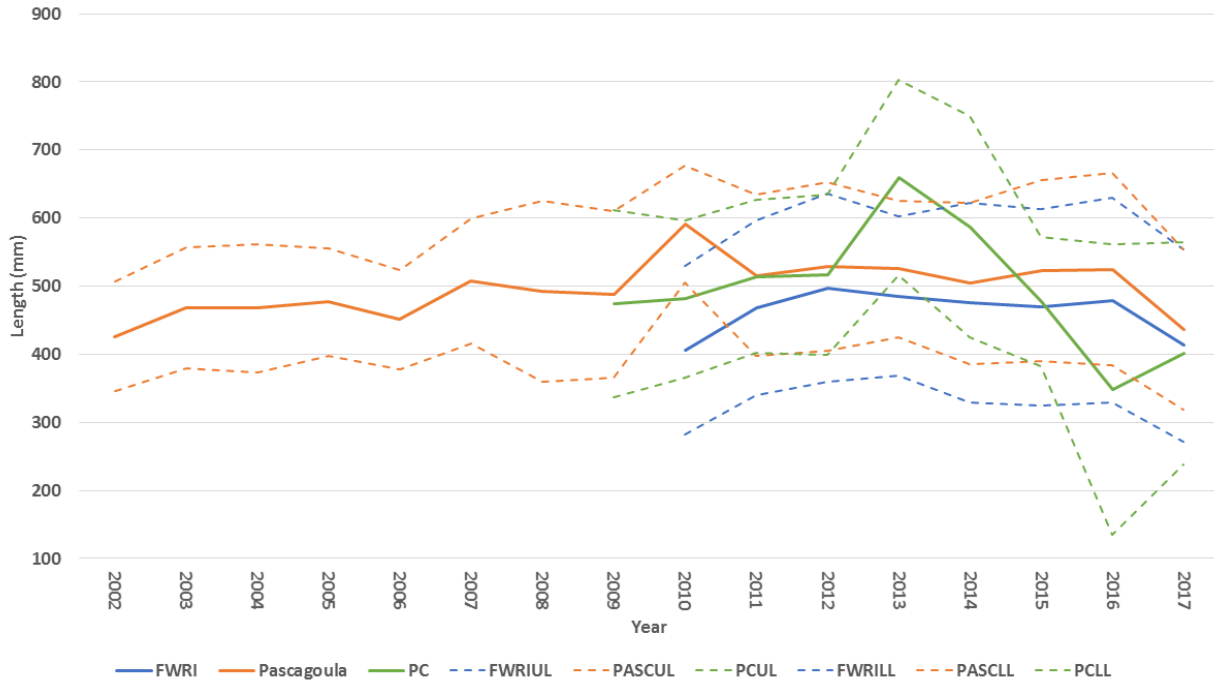




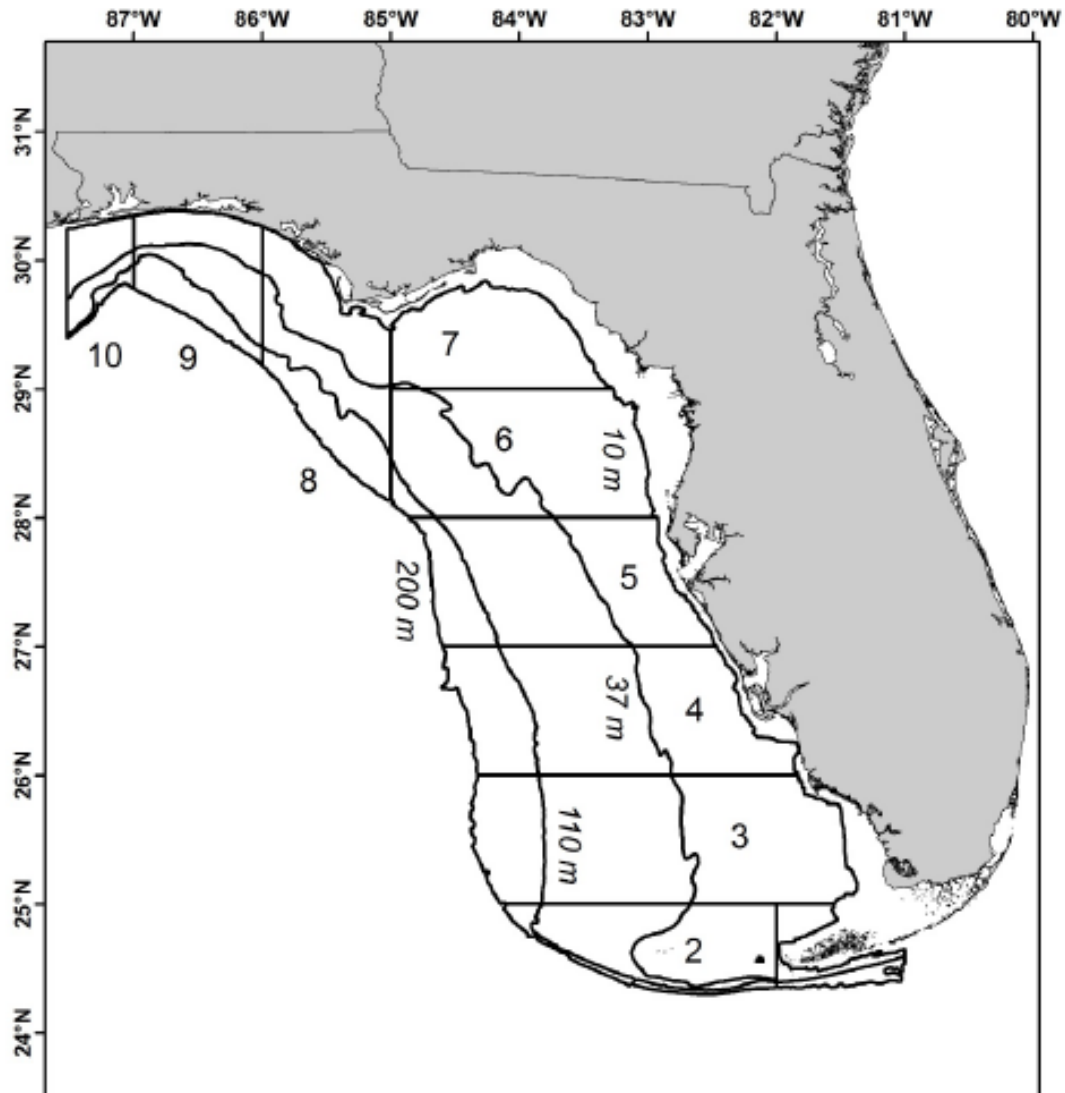
**Figure 2.31.** Map of the total video sites included in the index for the video survey across all years 1993-2017. Labs include the Florida Fish and Wildlife Research Institute (FWRI), NMFS Mississippi Laboratories (PASC), and NMFS Panama City (PC).



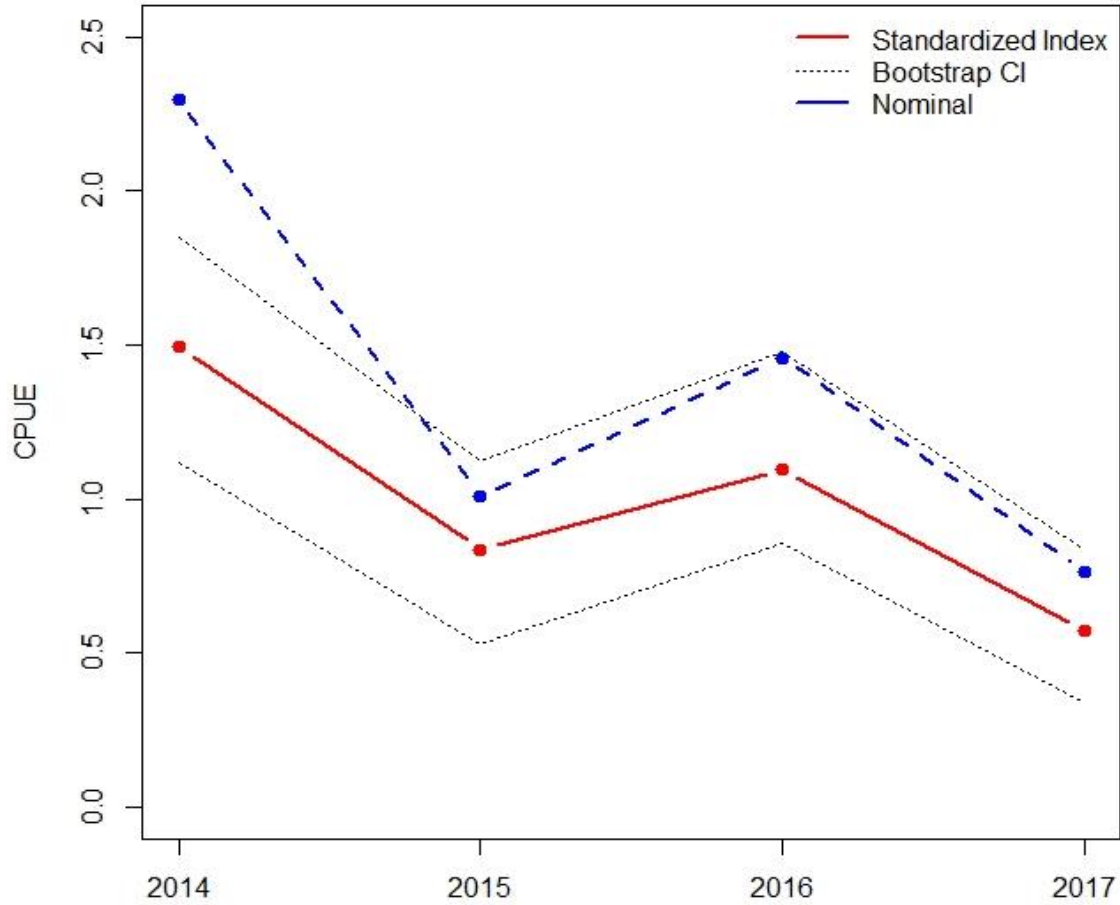
**Figure 2.32.** Index of relative abundance derived from the Combined Video Survey. (A) Comparison of standardized indices for SEDAR61 and SEDAR42 with 95% confidence intervals (shaded). (B) SEDAR61 and SEDAR42 indices have been normalized by their respective means. Note that the time series is not continuous, as evident by confidence intervals with no corresponding point estimates.



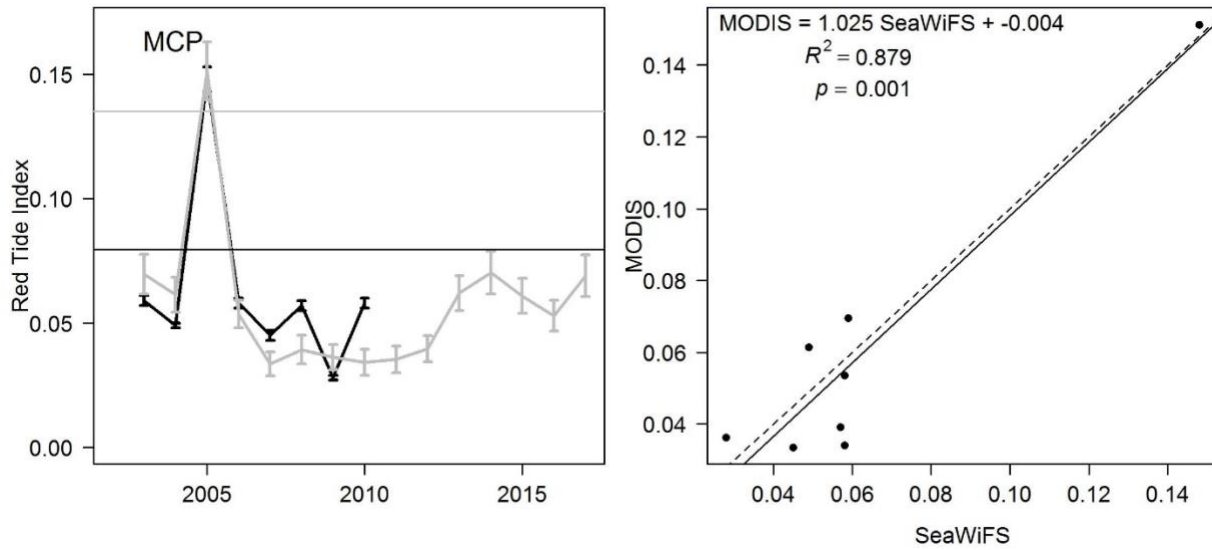
**Figure 2.33.** Comparison of mean length (solid lines) and standard error (dashed line) of Red Grouper from each video survey: FWRI (in blue), NMFS Mississippi Laboratories (orange), and NMFS Panama City Laboratory (green).



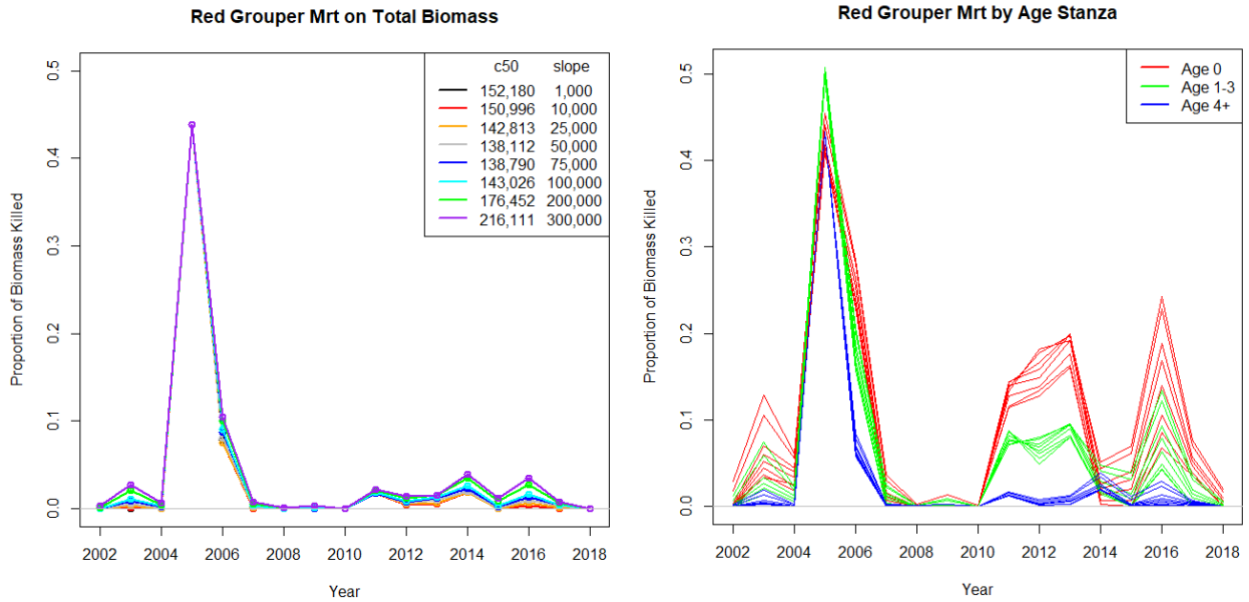
**Figure 2.34.** The Florida Fish and Wildlife Research Institute repetitive time drop survey area in the eastern Gulf of Mexico. Sampling effort was allocated among NMFS Shrimp Statistical Zones (4, 5, 9, and 10) as well as nearshore (9 – 36 m), offshore (37 – 109 m), and deep (110 – 180 m) depth strata.



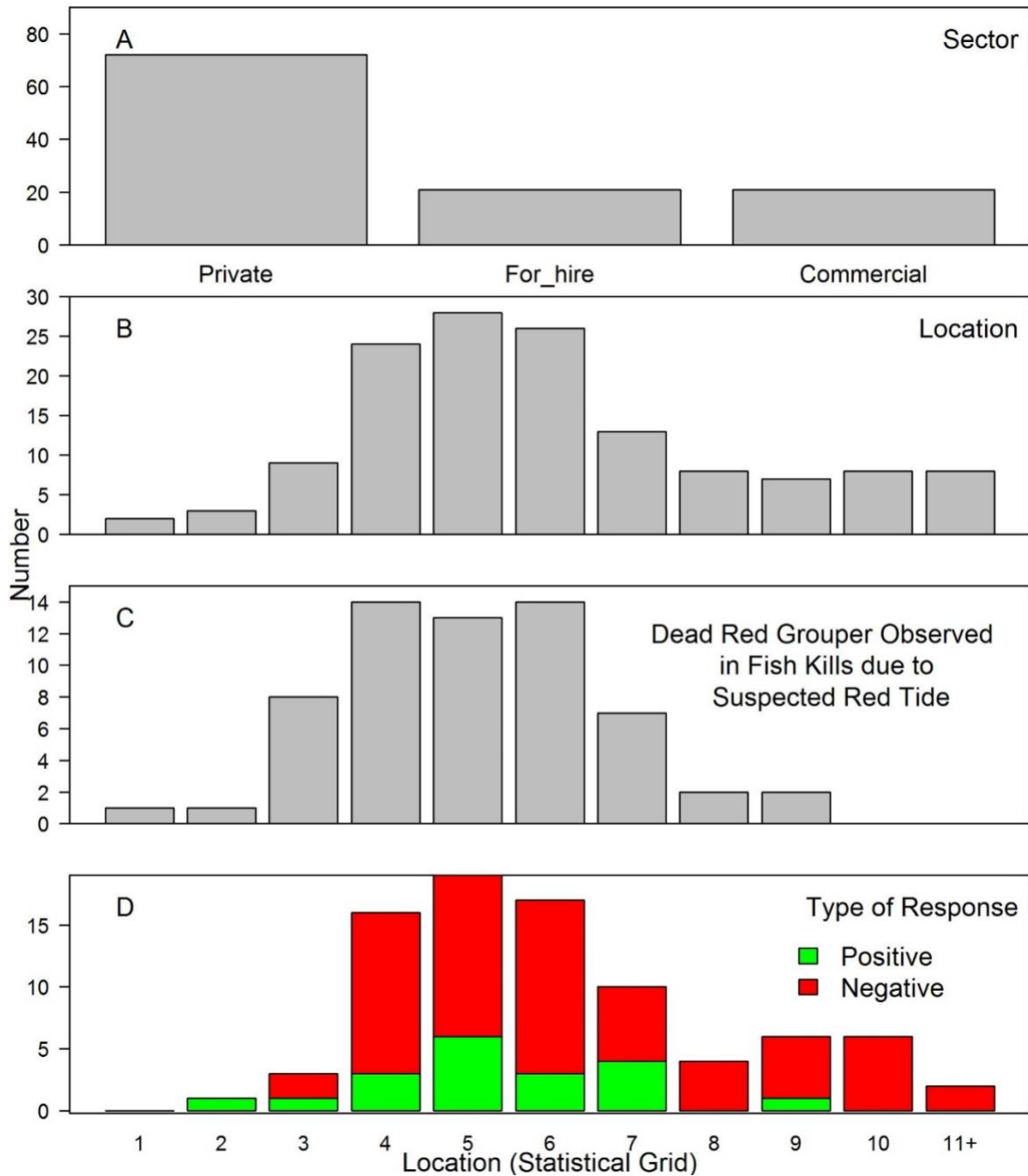
**Figure 2.35.** Relative standardized index (solid red line; number of fish per station) with 2.5% and 97.5% confidence intervals (black dotted lines) and the nominal CPUE (blue hashed line) for Red Grouper caught in the Florida Fish and Wildlife Research Institute repetitive time drop survey.



**Figure 2.36.** Comparison of relative indices of red tide severity and standard errors (vertical bars) derived from SeaWiFS (black) and MODIS (gray) satellite data. The right panel shows the linear relationship. The solid lines in the left panel identify the thresholds identified for SeaWiFS (black) and MODIS (gray) and the dashed line in the right panel identifies the 1:1 line.



**Figure 2.37.** Estimated trend in red tide mortality on Red Grouper from July 2002 to March 2018. Mortality is expressed as the proportion of the total biomass killed (left panel) and the proportion of biomass killed in each age stanza by red tides in each year (right panel). In the age stanza plots, multiple lines correspond to the different response curves evaluated.



**Figure 2.38.** Summary of findings from the Gulf of Mexico Fishery Management Council’s voluntary online data collection tool “Something’s Fishy with Red Grouper”. (A) The number of respondents by sector; (B) The number of respondents by location (NMFS Shrimp Statistical Zones; see **Figure 2.1**); (C) The number of respondents that observed Red Grouper in suspected red tide fish kills by location; and (D) The type of response, where negative refers to concerns over reduced abundance and positive refers to optimism (e.g., seeing lots of sub-legal Red Grouper).



### 3. STOCK ASSESSMENT METHODS

#### 3.1 Overview

The assessment model used for the SEDAR61 Gulf of Mexico Red Grouper stock assessment was Stock Synthesis version 3.30 after transitioning the continuity model from version 3.24 to 3.3 and obtaining identical model results (see **Section 4.12.6** for details). Descriptions of Stock Synthesis algorithms and options are available in the Stock Synthesis user's manual (Methot et al. 2018), the NOAA Fisheries Toolbox website (<http://nft.nefsc.noaa.gov/>), and Methot and Wetzel (2013). Stock Synthesis is an integrated statistical catch-at-age model, which projects forward from initial conditions using age-structured population dynamics equations. Statistical catch-at-age models are comprised of three modeling modules: the population dynamics module, an observation module, and a likelihood module. Each of the modules is closely linked. Stock Synthesis uses biological parameters (e.g., growth, fecundity, and natural mortality) to propagate abundance and biomass forward from initial conditions (population dynamics model) and develops predicted datasets based on estimates of fishing mortality, selectivity, and catchability (the observation model). Finally, the observed and predicted data are compared (the likelihood module) to determine best fit parameter estimates using a statistical maximum likelihood framework (see Methot and Wetzel, 2013 for a description of equations and complete modeling framework). The integrated approach to natural resource modeling aims to utilize available data in the least processed form possible in order to maintain consistency in error structure across data analysis and modeling assumptions, while more reliably propagating uncertainty estimates, especially in critical population parameters such as stock status and projected yield (Maunder and Punt, 2013).

Because of its extreme flexibility, there is not a single prototypical Stock Synthesis model. Depending on the life history and data availability of the modeled species, Stock Synthesis models can range from highly complex and data rich individual-based models to relatively simpler age-structured production models. The flexibility allows the user to input all data sources that are available, but can also lead to overparametrization if careful attention is not paid to model configuration and diagnostics. Although Stock Synthesis makes it relatively easy to implement highly complex models, models of moderate complexity are often best given the data limitations in most fisheries. Many of the modeling assumptions in Stock Synthesis have been thoroughly simulation tested. The framework is used for fisheries management of a wide variety of marine species worldwide, most notably for United States federally managed fish stocks in the northwest Pacific and Gulf of Mexico.

A model of moderate complexity was implemented for Gulf of Mexico Red Grouper. The model produces predicted data for four modeled fishing fleets (including landings, discards, age compositions, and discard length compositions where available), four CPUE indices, four fishery-independent surveys (including indices of relative abundance and length compositions), and a pseudo-fishing fleet to represent episodic natural mortality due to severe red tide events. Estimated parameters include two growth parameters (von Bertalanffy growth coefficient [ $K$ ] and the length at age 1 [ $L_{min}$ ]), virgin recruitment [ $\ln(R_0)$ ], variability in recruitment [ $\text{Sigma}R$ ,  $\sigma_R$ ], time-varying stock-recruit deviations, fishing mortality for each fleet and year it was

operating, red tide mortality in 2005 and 2014, length-based selectivity parameters for surveys with length composition data, length-based selectivity parameters for fisheries with discard length composition data (if available) and age composition data, and time-varying retention. A variety of derived quantities are produced including full time series of recruitment, abundance, biomass, spawning stock biomass (SSB), and harvest rate. Projections are implemented within Stock Synthesis starting from the year succeeding the terminal year of the assessment model utilizing the same population dynamics equations and modeling assumptions.

The r4ss software ([www.cran.r-project.org/web/packages/r4ss/index.html](http://www.cran.r-project.org/web/packages/r4ss/index.html)) was utilized extensively to develop various graphics for model outputs and was also used to summarize various output files and perform diagnostic runs.

### 3.2 Data Sources

A variety of data sources were used in the SEDAR61 stock assessment and are described in **Section 2**. The SEDAR61 assessment used many of the same datasets as the SEDAR42 base assessment with updated time series through 2017. However, strict continuity data streams were not provided for recreational datasets (landings, discards, or composition data) or commercial vertical line and longline discards due to substantial improvements in methodologies discussed in **Section 2**. A handful of new datasets were provided for the SEDAR61 assessment, some of which were included in the final SEDAR61 Base Model. Relative abundance and size composition from the FWRI Hook and Line Repetitive Time Drop Survey was incorporated into the SEDAR61 Base Model, whereas new red tide analyses were used to help parametrize the red tide pseudo-fishing fleet. The main data inputs used in the SEDAR61 assessment model are summarized below:

#### Life history

- Age and growth
- Natural mortality
- Maturity
- Sex transition
- Fecundity

#### Landings

- Commercial vertical line (metric tons): 1986-2017
- Commercial longline (metric tons): 1986-2017
- Commercial trap (metric tons): 1986-2006, 2011
- Recreational charter, private and headboat (thousands of fish): 1986-2017

#### Discards (thousands of fish)

- Commercial vertical line: 1993-2017
- Commercial longline: 1993-2017
- Commercial trap: 1990-2006
- Recreational charter, private and headboat: 1986-2017

#### Age composition of landings (1-year age bins, plus group ages 20 and older)

- Commercial vertical line: 1991-2017
- Commercial longline: 1991-2017
- Commercial trap: 1992-2006

- Recreational charter, private and headboat: 1991-2017
- Length composition of discards** (2-cm Fork Length bins)
  - Commercial vertical line: 2006-2017
  - Commercial longline: 2006-2017
  - Recreational charter, private and headboat: 2005-2007, 2009-2017
- Abundance indices**
  - Fishery-independent
    - SEAMAP Summer Groundfish: 2009-2017
    - NMFS Bottom Longline: 2001 & 2003-2017
    - Combined Video: 1993-1997, 2002 & 2004-2017
    - FWRI Hook and Line Repetitive Time Drop Survey: 2014-2017
  - Fishery-dependent
    - Commercial vertical line: 1993-2009
    - Commercial longline: 1993-2009
    - Recreational charter and private (MRIP): 1986-2017
    - Recreational headboat (SRHS): 1986-2017
- Length composition data from fishery-independent surveys** (2-cm length bins)
  - SEAMAP Summer Groundfish: 2008-2017
  - NMFS Bottom Longline: 2001-2017
  - Combined Video: 2008-2017
  - FWRI Hook and Line Repetitive Time Drop Survey: 2014-2017
- Discard mortality**
  - Commercial vertical line
  - Commercial longline pre-IFQ
  - Commercial longline post-IFQ
  - Commercial trap
  - Recreational fleets
- Environmental Considerations**
  - Red tide (mortality)

**Figure 4.1** illustrates the data sources and their corresponding temporal scale. Detailed descriptions of the data inputs can be found in the various SEDAR61 working papers on the SEDAR website (<http://sedarweb.org/sedar-61>).

### 3.3 Model Configuration

#### General Structure

- Age structured model: ages 0 to 20+
- Time series: 1986-2017, starting in a fished state and estimating initial conditions
- One area, one season model
- Combined gender model, with maturity, protogyny, and fecundity a function of age
- Time-varying retention to account for changes in size limits and IFQ

The SEDAR61 Continuity Model configuration was identical to the SEDAR42 Final Model that was used to provide management advice (RW2 in SEDAR42 [2015]), with the exception of a few key data inputs. The commercial vertical line and longline discard estimates and recreational

data inputs were solely provided using improved methodology. The SEDAR61 Base Model configuration was modified considerably from the SEDAR61 Continuity Model to implement best practices, improve model stability and diagnostics, and obtain better fits to data. In addition to the data changes discussed throughout **Section 2** and summarized below, major changes to the SEDAR61 Base Model configuration included:

### **Summary of major deviations from SEDAR61 Continuity Model**

- Data:
  - Update index of relative abundance from the Combined Video Survey using habitat-based methodology and length composition to include lengths from all three surveys (NMFS SEAMAP Reef Fish, NMFS Panama City, and FWRI)
  - Update recreational age composition using new MRIP size data that incorporates imputed lengths and sample weights and weight the charter/private age composition and headboat age composition by their respective landings
  - Update growth (and Natural Mortality which requires growth parameters)
  - Update fecundity (use updated SEDAR61 fecundity-at-length relationship and convert fecundity-at-length to fecundity-at-age using the growth curve)
  - Use square root of sample sizes as input sample sizes for length and age composition data
- New Data:
  - Incorporate index of relative abundance and length composition from the FWRI Hook and Line Repetitive Time Drop Survey
- Assessment Model Configuration:
  - Start model in 1986 and re-estimate initial equilibrium catches using an average of catches during the first five years of the time series
  - Estimate the von Bertalanffy growth coefficient ( $K$ ) and the length at the minimum age ( $L_{min}$ )
  - Modify the red tide fleet to operate solely in years with severe red tides (2005 and 2014); do not include zero values in red tide index as in SEDAR42 Final Model
  - Replace age-based selectivity with length-based selectivity for fishing fleets
  - Parametrize NMFS Bottom Longline and Combined Video Survey selectivity patterns as logistic (i.e., asymptotic)
  - For retention patterns, fix the inflection point at the size limit for all fleets and the asymptote at full retention for commercial fishing fleets
  - Iteratively reweight the effective sample sizes (best practices) for age and size composition and remove extra weight ( $\lambda = 5$ ) that was added to indices in the SEDAR42 Final Model to upweight indices at the expense of composition data

#### **3.3.1 Life History**

The majority of life history inputs were incorporated into the SEDAR61 Base Model as fixed parameters as in SEDAR42. Data inputs concerning the weight-length relationship (**Section 2.2.1**), maturity schedule (**Section 2.2.5.1**), and the sexual transition schedule (**Section 2.2.5.2**) remained unchanged from those values used in SEDAR42. The fixed length-weight relationship was used to convert body length (cm) to body weight (kg) in Stock Synthesis (**Figure 4.2**).

Growth was modeled externally from the assessment model using a single size-modified von Bertalanffy growth curve for both sexes combined (**Section 2.2.2**). The von Bertalanffy growth curve parameters and variability in size-at-age parameters were updated for SEDAR61 using additional data. Growth within Stock Synthesis was modeled with a three parameter von Bertalanffy equation: (1)  $L_{min}$  (cm FL), the size of age-1 Red Grouper (cm FL); (2)  $L_{max}$  (cm FL), the size of maximum aged Red Grouper; and (3)  $K$  ( $year^{-1}$ ), the growth coefficient. In Stock Synthesis, when fish recruit at the real age of 0.0 they have a body size equal to the lower limit of the first population bin (fixed at 2 cm FL). Fish then grow linearly until they reach a real age equal to the input value of  $A_{min}$  (growth age for  $L_{min}$ ) and have a size equal to the  $L_{min}$ . As they age further, they grow according to the von Bertalanffy growth equation (**Figure 4.2**).  $L_{max}$  was specified as equivalent to  $L_{inf}$ . Two additional parameters are used to describe the variability in size-at-age and represent the CV in length-at-age at  $A_{min}$  (age 1) ( $CV_{young}$ ) and  $A_{max}$  (age 20) ( $CV_{old}$ ). For intermediate ages a linear interpolation of the CV on mean size-at-age is used. During SEDAR42, all five growth parameters ( $L_{max}$  [i.e.,  $L_{inf}$ ],  $L_{min}$ ,  $K$ ,  $CV_{young}$ ,  $CV_{old}$ ) were fixed within the Stock Synthesis model. For the SEDAR61 Base Model, both  $K$  and  $L_{min}$  were estimated after observing improved model fits to composition data, with starting values as recommended in **Section 2.2.2**.

The natural mortality rate ( $M$ ) was assumed constant over time, but decreasing with age. The Lorenzen (2005) age-specific vector of  $M$  was re-estimated for SEDAR61 using the updated growth curve (**Section 2.2.3**) and fixed within the Stock Synthesis model.

Red Grouper are protogynous hermaphrodites (female at birth, then a portion of the population transitions to male). The combined gender Stock Synthesis model treated males and females identically as in SEDAR42. Hermaphroditism was accounted for implicitly in the fecundity vector in the model. To account for a decrease in fecundity as females transition and become males, total fecundity-at-age was calculated as the proportion female (**Section 2.2.5.2**; unchanged from SEDAR42)  $\times$  proportion mature (**Section 2.2.5.1**; unchanged from SEDAR42)  $\times$  batch fecundity (**Section 2.2.5.3**). The SEDAR61 DW/AW Panel recommended the use of batch fecundity as a function of length (rather than age as used in SEDAR42) and to convert it to age using the growth curve. This decision was based on the relationship of fecundity-at-length being considered a better biological determinant given the sensitivity of the fecundity-at-age to a few older individuals. As in SEDAR42, the combined fecundity-at-age vector was fixed within the Stock Synthesis model.

### 3.3.2 Recruitment Dynamics

The Beverton-Holt stock-recruitment model was used in this assessment. The stock-recruit function (representing the arithmetic mean spawner-recruit levels) requires three parameters: steepness which characterizes the initial slope of the ascending limb (i.e., the fraction of virgin recruits produced at 20% of the equilibrium spawning biomass); the virgin recruitment ( $R_0$ ; estimated in log space) which represents the asymptote or unfished recruitment levels; and the variance term ( $SigmaR$ ) which is the standard deviation of the log of recruitment (it both penalizes deviations from the spawner-recruit curve and defines the offset between the arithmetic mean spawner-recruit curve and the expected geometric mean from which the deviations are

calculated). Although these parameters are often highly correlated, they can be simultaneously estimated in Stock Synthesis.

Following SEDAR42, two parameters of the stock recruitment relationship were estimated in the model: (1) the virgin recruitment ( $\text{Ln}(R_0)$ ); and (2) the standard deviation in recruitment ( $\text{Sigma}R$ ). While estimation of steepness was explored through sensitivity runs, diagnostics revealed greater variability in estimated virgin conditions and poorer overall diagnostics. Therefore, steepness remains fixed at 0.99 as recommended by the SEDAR42 Review Panel.

Annual deviations from the stock-recruit function were estimated in Stock Synthesis as a vector of deviations forced to sum to zero and assuming a lognormal error structure. Annual deviations were estimated solely for the data-rich period spanning 1993-2017, which corresponds to the time series of age composition data. Initial modeling attempts also estimated recruitment deviations for the early data-poor period (i.e., prior to 1993) under the assumption that the age composition data provided some indication of recruitment in the early data-poor period. However, these early recruitment deviations were poorly estimated and had very high CVs, which led to model instability, particularly in initial conditions. Since Stock Synthesis assumes a lognormal error structure for recruitment, expected recruitments need to be bias adjusted. Methot and Taylor (2011) recommend that the full bias adjustment only be applied to data-rich years in the assessment. This is done so Stock Synthesis will apply the full bias-correction only to those recruitment deviations that have enough data to inform the model about the full range of recruitment variability (Methot et al. 2018). Full bias adjustment was used from 1993 to 2014. Bias adjustment was phased out over the last three years (2015-2017), decreasing from full bias adjustment to no bias adjustment.

### **3.3.3 Starting Conditions**

A major research recommendation following SEDAR42 was to re-evaluate the start year of the assessment model. SEDAR42 initially developed a proposed base model starting in 1986, primarily due to precedence of that start year in previous Red Grouper stock assessments and data availability and reliability. During SEDAR42, the reliability of the landings time series was discussed in detail. The SEDAR42 Commercial Workgroup ultimately concluded that the landings after 1986 were most accurate because trip tickets began in 1986 and landings were generally reported to species (i.e., as opposed to “unclassified” grouper). Landings between 1962 and 1985 were deemed relatively accurate. While commercial landings are available for Red Grouper as far back as 1880, landings prior to 1963 are highly uncertain. Reported landings of grouper were missing for the majority of years, assumptions on species apportionment and US caught fish were required, and sporadic data exists detailing the removals of Red Grouper in US waters by Cuban vessels prior to the establishment of the Exclusive Economic Zone in 1976.

During the SEDAR42 Review Workshop, the SEDAR42 Review Panel recommended starting the model in 1993 because much of the informative data series started in 1993, namely the commercial discards and fishery-independent surveys. This decision was based largely on poor fits in commercial discards and indices, and starting in 1993 led to a “more consistent situation for discards (and for the video survey)”. Ideally, early starts as close to unfished conditions as possible are preferable because this provides additional information about stock productivity.

During the SEDAR61 Assessment Workshop webinars, model runs starting in 1963 and 1986 accompanied the continuity model which started in 1993. The SEDAR61 DW/AW Panel recommended starting the model in 1986 to take advantage of earlier data streams such as the recreational CPUE indices. Concerns over the longer time series prevented a start in 1963, including historical removals in light of MRIP changes (i.e., need to revisit effort used to recreate historic landings) and Cuban landings. Future assessments should revisit development of a historical time series of removals of Red Grouper and include estimates of uncertainty, which can be included in Stock Synthesis version 3.3 as annual CVs accompanying annual landings estimates.

Since removals of Red Grouper are known to have occurred in the Gulf of Mexico as early as 1880, the stock was not assumed to be at equilibrium at the 1986 start year for the SEDAR61 Base Model. Starting the assessment model in 1986 requires the estimation of initial conditions via initial equilibrium catches which are used to calculate initial fishing mortality rates. Equilibrium catch is the catch taken from a stock for which removals and natural mortality are balanced by stable recruitment and growth. Post-SEDAR42 reviews at an advanced Stock Synthesis Workshop in December 2015 revealed that the initial conditions in the Red Grouper Final Model starting in 1993 that was used for management advice were highly uncertain and much too high. For SEDAR61, initial equilibrium catches were recalculated as the average catch over the first five years of the assessment time series.

### ***3.3.4 Fleet Structure***

Four fishing fleets and one pseudo-fishing fleet were included in the model. The fishing fleets represent the commercial vertical line, commercial longline, commercial trap, and recreational, whereas the pseudo-fishing fleet represents dead discards due to red tides. A single recreational fleet was used because the headboat fleet represented a very small percentage of overall Red Grouper landings (<5%), which follows the SEDAR42 Review Panel recommendation.

### ***3.3.5 Catch-per-unit-effort (CPUE) Indices***

Four fishery-dependent CPUE indices were fit in the model including: commercial vertical line (pre-IFQ), commercial longline (pre-IFQ), recreational charter/private (MRIP/MRFSS), and recreational headboat (SRHS). CPUE was treated as an index of biomass or abundance (depending on whether the corresponding catch was in weight or numbers) where the observed standardized CPUE time series was assumed to reflect annual variation in population trajectories. The MRIP charter/private CPUE index was modeled as a total catch index which included Red Grouper landed whole and observed by interviewers (Type “A”), Red Grouper reported as killed by the fishers (Type “B1”) and live released Red Grouper (Type “B2”). The remaining three CPUE indices were modeled as indices of landings only. Each modeled CPUE index assumes the same selectivity as the associated fleet. As noted in **Section 2.3.5**, the commercial vertical line and longline CPUE indices were truncated in 2009 due to the implementation of IFQs starting in 2010 which changed the behavior of fishermen. Time and resource limitations prevented the updating and re-evaluation of these CPUE indices during this assessment.

### ***3.3.6 Surveys***

Indices of abundance from four fishery-independent surveys were fit in the model: SEAMAP Summer Groundfish Survey; NMFS Bottom Longline Survey; a Combined Video Survey (NMFS SEAMAP Reef Fish, NMFS Panama City, and FWRI) based on an improved habitat-based methodology, and the FWRI Hook and Line Repetitive Time Drop Survey. These surveys were treated in the same way as CPUE indices, except that each survey had its own unique selectivity function estimated from length composition data. The FWRI Hook and Line Repetitive Time Drop Survey is considered new data as this survey was not available during SEDAR42.

### 3.3.7 Selectivity

Selectivity represents the probability of capture by age or length for a given fishery and subsumes a number of interrelated dynamics (e.g., gear type, targeting, and availability of fish due to spatial structure). For the SEDAR42 assessment, three types of selectivity functions were utilized: a 2 parameter age-based function specifying the minimum and maximum age where Red Grouper were fully selected (i.e., selectivity = 1), a 6 parameter double normal function, and an age-based random walk (see Methot et al. 2018). The double normal is a combination of two normal distributions; the first describes the ascending limb, while the second describes the descending limb, and the maximum selectivity of the two functions is joined by a line segment. The double normal function is extremely flexible and can allow for domed or essentially logistic selectivity. However, due to the increased number of parameters, it can be more unstable than other selectivity functions. It is appropriate when robust length or age compositions are available with sufficient numbers of larger or older fish to freely estimate all parameters (especially the descending limb). In the age-based random walk selectivity approach, the age-specific selectivity parameters represent the rate of change from the selectivity value for the previous age. Because each parameter is constrained, the number of estimated parameters is effectively much less than the number of ages and selectivity values can be fixed for ages with limited information (e.g., at the value for the oldest estimated age). The age-based random walk function can be useful when dome-shaped selectivity is suspected, but limited or truncated age compositions may lead to instability in parameter estimates.

SEDAR42 used an empirical random walk-at-age selectivity pattern for the commercial and recreational fishing fleets, where the first two ages (ages 0 and 1) were fixed parameters and the parameters for the remaining ages were estimated. A normal prior was used to penalize the random walk between ages, and the assumed distribution of the penalty for age-2 through age-11 was  $\sim N(0, 0.25)$  and for age-12 through age-20 was  $\sim N(0, 0.1)$ . Length-based selectivity functions were specified for all fishery-independent surveys using the double normal selectivity pattern, with all six parameters freely estimated for each survey. The selectivity pattern of the red tide pseudo-fishing fleet was specified so that all Red Grouper ages 0 and older were 100% selected for by the red tide, following anecdotal evidence of severe mortality across age classes in the absence of quantitative data to parametrize selectivity.

Review of the SEDAR42 Final Model during an advanced Stock Synthesis Workshop in December 2015 recommended the replacement of age-based selectivity with size-based selectivity for the fishing fleets. The poor fits to size composition were likely a result of the



SEDAR42 Final Model configuration, which did not include size-selectivity for the fishing fleets and externally fixed all the growth parameters. In addition, model diagnostics of the SEDAR42 Final Model revealed many poorly estimated parameters and considerable model instability, as the jitter analysis resulted in only 50% of model runs within five negative log-likelihood units of the selected model. As a result, the SEDAR61 DW/AW Panel supported switching to length-based selectivity functions for all fishing fleets and re-parametrizing surveys that exhibited asymptotic selectivity with logistic selectivity to reduce overparametrization. Logistic selectivity was implemented for the NMFS Bottom Longline Survey and Combined Video Survey following estimated patterns for the SEDAR42 Final Model (i.e., both asymptotic) and for the FWRI Hook and Line Repetitive Time Drop Survey which covers key adult Red Grouper habitat. A logistic curve implies that fish below a certain size range are not vulnerable, but then gradually increase in vulnerability with increasing size until all fish are fully vulnerable (asymptotic selectivity curve). Two parameters describe logistic selectivity: the length at 50% selectivity, and the difference between the length at 95% selectivity and the length at 50% selectivity, which were estimated in this assessment. Given large correlations between these two parameters ( $> 0.70$ ), a normal prior was used on the size parameter based on the model estimated value and its standard deviation ( $SD$ ).

Selectivity patterns for all fishing fleets and the SEAMAP Summer Groundfish Survey were estimated to be dome-shaped, as initial model runs freely estimated all six parameters. However, when all six parameters were estimated freely (see **Section 3.4.4** for details on phases), large correlations ( $> 0.7$ ) were prevalent between selectivity parameters, which led to instability when jittering the assessment model. In order to improve model stability, select parameters were either fixed at estimated or realistic values or were given normal priors based on the model estimated value and the  $SD$ . For the SEAMAP Summer Groundfish Survey, and following the estimation of clearly dome-shaped patterns for the various fisheries, estimation ignored the first and last size bins and allowed Stock Synthesis to decay the small and large Red Grouper selectivity according to parameters of ascending width and descending width, respectively. For the SEAMAP Summer Groundfish Survey and recreational fleet, all estimated selectivity parameters were given prior estimates based on the model estimated values and  $SD$  to improve model stability following either highly correlated parameters or poorly estimated parameters. Stable selectivity patterns for the commercial fisheries required a prior on the parameter specifying the width of the plateau, which was often estimated with high uncertainty and correlated with other parameters. In addition, the parameters describing the ascending and descending width of the selectivity curve were often poorly estimated and were therefore fixed at values that allowed a realistic gradual increase and decrease (as opposed to a sharp increase or decrease).

Selectivity patterns were assumed to be constant over time for each fishery and survey. The Red Grouper fishery has experienced changes in management regulation over time, which were assumed to influence the discard patterns more so than selectivity. As such, these changes were accounted for in the assessment model using time-varying retention patterns and modeling discards explicitly.

### **3.3.8 Retention**

Following SEDAR42, time-varying retention was implemented to account for changes in management regulations (**Figure 4.3**). For the commercial fleets, the size limit switched from 20 inches total length (TL) (50.8 cm TL, 48.80 cm FL) in 2008 to 18 inches TL (45.7 cm TL, 43.97 cm FL) in 2009. The reduction in the commercial size limit was followed by the implementation of the individual fishing quota (IFQ) program in 2010. Similar to the commercial fishery, a 20 inch TL size limit (50.8 cm TL, 48.80 cm FL) was implemented for the recreational fishery in federal waters starting in 1990 until present. Prior to 1990, an 18 inch TL size limit (45.7 cm TL, 43.97 cm FL) was implemented in Florida state waters. The retention patterns were assumed to change with the changes in the size limit.

For each fishery, the retention function was specified as a logistic function consisting of four parameters: (1) the inflection point, (2) the slope, (3) the asymptote, and (4) the male offset inflection, which is not applicable to this model and assumed to be zero. During SEDAR42, the inflection, slope and asymptote retention parameters were fixed for the earlier 1990-2008 time block but estimated for the more recent 2009-2013 time block given the availability of discard length composition data throughout the second time block. For the 1990-2008 time block, the retention pattern for both the commercial vertical line and longline fleets was assumed to be knife-edge at the size limit where 100% of individuals were retained above the size limit. This was also the assumed relationship for the commercial trap fleet since its discard observations only pertained to this time block. Using the discard length composition data during the 2009-2017 time block for SEDAR61, the parameters describing the inflection point, slope, and asymptote of each retention pattern for the commercial handline and longline fleets were freely estimated. While initial SEDAR61 model runs followed this configuration, poor model convergence and diagnostics led to the fixing of the inflection point (at the size limit) and fixing of the asymptote at the maximum value, which assumes that all fish above the size limit are retained. While Red Grouper can be discarded above the size limit since the implementation of the IFQ in 2010 for both the commercial vertical line and longline fisheries, the large majority of Red Grouper are kept (**Figure 4.4**). To improve model stability, other changes were required including the fixing of the width of the retention function for the commercial vertical line during 1990-2008, which tended to be estimated at the lower bound in alternative model runs identified in initial jitter analyses.

For the recreational fleet, the retention pattern for the 1986-1989 time block was assumed to be knife-edge at the size limit in Florida state waters where 100% of individuals were retained above the size limit. The parameters describing the retention pattern associated with the 1990-2017 time block and 20 inch TL recreational size limit in Federal waters were freely estimated. Similar issues with model stability were noted for the recreational retention pattern, which led to the fixing of the inflection point at the size limit and the width of the retention function which was fixed at the estimated value (2.865,  $CV=0.101$ ) to improve model stability. The asymptote of the retention function is the only estimated parameter, and allows for less than 100% retention due to bag limits and other restrictions.

### **3.3.9 Discards**

Discards were calculated and fit within the model. Dead discards from the directed fleets were estimated using retention curves to account for discards that resulted from the implementation of

minimum size regulations and assumed discard mortality rates (to calculate dead discards from total discards). The model estimated total discards based on the selectivity and retention functions, then calculated (and fit) dead discards based on the discard mortality rate. Fleet-specific discard mortality rates were treated as fixed model inputs (see **Section 2.2.4**). For the commercial longline, the post-IFQ discard mortality estimate of 44.1% was used. No time blocks were specified for the commercial longline, given the similarity in the discard mortality rates pre-IFQ (41.4%) and post-IFQ (44.1%).

### ***3.3.10 Composition data and aging error***

Landings by fleet and associated age compositions were calculated based on estimated fleet specific continuous fishing mortality rates and age-specific selectivity curves derived from size-based selectivity using Baranov's catch equation, and fit directly in the model. Similarly, length compositions for surveys were calculated by estimating survey-specific selectivity functions and fit directly in the model. An aging error matrix was input as a vector of mean ages and standard deviation of those ages, and enabled the creation of a distribution of observed ages (e.g. age with possible bias and imprecision) from true ages (**Figure 4.5**).

### ***3.3.11 Accounting for Mortality due to Red Tide***

Mortality due to severe red tides has been included in Red Grouper assessments since SEDAR12 (SEDAR 2006), where an extra mortality term was estimated in 2005. The inclusion of red tide mortality allowed the assessment model to better explain the sudden declines in abundance indices between 2005 and 2006. The SEDAR42 Assessment Panel recommended the continued consideration of a mortality event associated with the 2005 red tide on the West Florida Shelf in the SEDAR42 assessment model.

During SEDAR42, multiple approaches for incorporating red tide mortality were explored (see SEDAR42-RW01 for review). Ultimately, the Assessment Panel recommended parameterizing red tide as a pseudo-fishing fleet to model removals of Red Grouper from red tide. All Red Grouper encountered were discarded with 100% mortality and therefore no catches were required as inputs. This approach was preferred because it allowed for the level of mortality to be estimated by the assessment model rather than input as a fixed parameter. In addition, the fishing fleet approach gave similar results as the approach that used a fixed constant red tide mortality applied to all ages, and was thought to better represent model uncertainty due to red tide mortality events.

During SEDAR42, an index of fishing effort for the red tide fleet was used to drive mortality and was based on the Walter Threshold Index (Walter et al. 2013), a binary index where red tide events were depicted as present (= 1, solely in 2005) or absent (= 0) between 1998 and 2010 based on the predicted probability of a severe red tide bloom. This index assumed that negative effects, i.e., red tide mortality, only occurred under severe red tide events. Baseline levels of red tide mortality are likely already accounted for within estimates of natural mortality derived from empirical data.

Modifications to how the red tide fleet was operating were required during SEDAR61, since two severe red tide events have occurred during the modeled time series. Inclusion of a binary index in the model (i.e., 1 in both 2005 and 2014), forced red tide mortality to be equal in magnitude across those years, which may not reflect actual conditions. Therefore, the red tide index was not included as a driver of  $F$  in the SEDAR61 Base Model; instead, the model used information from data sources already in the model to scale red tide removals in 2005 and 2014. Selectivity of the red tide fishing fleet was assumed constant at age (i.e. = 1) due to the lack of data on size-specific red tide mortality, although this assumption appears supported by the index of red tide mortality analysis discussed in **Section 2.6.2**, which shows high red tide mortality for all age classes in 2005.

### **3.4 Maximum Likelihood and Uncertainty**

A maximum likelihood approach was used to assess goodness of fit to each of the data sources. Each dataset had an assumed error distribution and an associated likelihood component, the value of which was determined by the difference in observed and predicted values along with the assumed variance of the error distribution. The total likelihood was the sum of each individual component. A nonlinear iterative search algorithm was used to minimize the total negative log-likelihood across the multidimensional parameter space in order to determine the parameter values that provided the global best fit to all the data. With this type of integrated modeling approach, data weighting (i.e., the variance associated with each dataset) can greatly impact model results, particularly if the various datasets indicate differing population trends. Ideally, the model would allow the data to ‘self-weight’ in order to determine the relative variance among datasets. However, it is seldom possible to freely estimate all the variance terms in addition to the set of model parameters, and variance terms must be input based on calculated variance from the observed data. The latter approach suffers from a lack of information regarding relative variance among different datasets. Ultimately, expert judgement usually must be used to input relative variance components, and this is the approach used in Stock Synthesis.

#### **3.4.1 Error Structure**

The landings data, discards, CPUE indices, and surveys all assumed a lognormal error structure. The commercial landings were assumed to be most reliable over the modeled time period because this information was collected in the form of a census, as opposed to being collected as part of a survey like most other input data. The recreational landings were likely slightly less reliable, because the charter/private component was collected using the MRIP survey. Discards were assumed to be somewhat reliable data given the limited sampling that occurs and the large number of assumptions needed to calculate them. The CPUE and survey indices were assumed to be noisy, mainly due to lower sample sizes and uncertainty in the relationship between CPUE and abundance trends.

In the absence of annual estimates of variability, the landings and discard data were assumed to have a constant variance throughout the time period, while interannual variation in the CPUE and survey indices was estimated through the standardization techniques used to determine the final observed index values. For the indices, if the variance of the observations was available only as a coefficient of variation ( $CV$ ; standard error divided by mean), it was converted to a

standard error ( $SE$ ) in log space (required for input to Stock Synthesis for lognormal error structures) using:

$$SE = \sqrt{\log_e(1 + CV)^2}. \quad (1)$$

The age and discard length composition data for the various fisheries and length composition data for the surveys were assumed to follow a multinomial error structure where the variance was determined by the input effective sample size ( $N_{eff}$ ). For the multinomial likelihood a smaller sample size represents higher variance and vice versa, because  $N_{eff}$  is meant to represent the number of fish sampled each year to determine the composition. Observed sample sizes are often overestimated for fisheries data, because samples are rarely truly random or independent (Hulson et al. 2012). In addition, using higher effective sample sizes can lead to the composition data dominating the likelihood resulting in reduced fit to other data sources. Iterative reweighting is often undertaken in order to adjust the effective sample size to better represent the residual variance between observed and predicted values (Methot and Wetzel, 2013).

A penalty on deviations from the stock-recruit curve was also included (essentially a Bayesian prior) in order to limit recruitment deviations from differing too greatly from the assumed stock-recruit relationship. The variance term was controlled by the  $SigmaR$  parameter.

Parameter bounds were set to be relatively wide and were unlikely to truncate the search algorithm.

### 3.4.2 Data Weighting

Following SEDAR42, the input standard errors for the landings for the commercial and recreational fleets were set to 0.15 and 0.30, respectively. Both commercial and recreational discards were given a standard error of 0.29. Each of the indices were scaled to an average standard error of 0.3 across the entire time series, but the relative annual variation was maintained in the scaling. This is a more appropriate approach than using the output standard error from the standardization routine directly in Stock Synthesis because it avoids undue influence of any single index. Given that each index is standardized independently using slightly different techniques, it would not be expected that the output standard error from each would be directly comparable. Therefore, scaling them each to a common mean allows them to be placed on equal footing within the assessment.

The SEDAR61 DW/AW Panel recommended substantial changes to the treatment of the length and age composition data. Rather than capping observed sample sizes at upper limits of 100 samples for discard length composition data and 200 samples for age composition data as in SEDAR42, the SEDAR61 DW/AW Panel recommended that the input sample sizes for the length and age composition data be the square root of observed sample sizes to prevent overfitting the composition data and to maintain the interannual differences in data quality that would otherwise be lost by an arbitrary cap. In addition, the Francis iterative reweighting method was used for weighting length and age composition within the model (Francis 2011). The Francis method reweights composition data based on variability in the observed mean length or age by year. Within this approach, the sample sizes are adjusted such that the fit of the expected mean

length or age should fit within the uncertainty intervals at a rate which is consistent with variability expected based on the adjusted sample sizes. An iterative approach was then utilized to determine the effective sample sizes that most accurately reflected the data (i.e., the input effective sample size converged to the estimated effective sample size based on residual variance). The final effective sample sizes for each year are provided on the figures illustrating the age composition and length composition (given by  $N_{adj}$  in each panel).

### 3.4.3 Uncertainty Estimation

Uncertainty estimates for estimated and derived quantities were calculated based on the asymptotic standard error determined from the inversion of the Hessian matrix (i.e., the matrix of second derivatives was used to determine the level of curvature in the parameter phase space and to calculate parameter correlation; Methot and Wetzel, 2013). Asymptotic standard errors provided a minimum estimate of uncertainty in parameter values.

### 3.4.4 Estimated Parameters

A total of 178 parameters were estimated for the base case model (**Table 4.1**). Of the 178 parameters, 121 were annual fleet specific fishing mortality rates. The remaining 57 estimated parameters include four initial fishing mortality rates, 24 parameters used to estimate selectivity and retention curves, 25 annual recruitment deviations, two growth parameters, and two recruitment parameters. **Table 4.1** includes predicted parameter values from Stock Synthesis, the range of values a parameter could take, their associated standard deviations and coefficient of variation, the prior if used, and the phase the parameter was either estimated (positive phase) or fixed (negative phase). Parameter bounds were selected to be sufficiently wide to avoid truncating the searching procedure during maximum likelihood estimation. The soft bounds option in Stock Synthesis was utilized when fitting the assessment model which creates a weak penalty to move parameters away from the bounds (Methot et al. 2018). With the exception of the retention parameter controlling the slope of the curve for the commercial vertical line and recreational fisheries, which were occasionally estimated at bounds during alternative model runs in the jitter analysis, no parameters were estimated near bounds during the model bridging exercise in SEDAR61.

Parameters designated as fixed were held at their initial values. Parameters that were estimated in the first phase included  $\ln(R_0)$ , initial fishing mortality rates, and annual fleet specific fishing mortality rates. Selectivity parameters specifying the peak of the double normal pattern and the logistic pattern were estimated in phase 2, whereas selectivity parameters specifying the top, ascending or descending limb of the double normal pattern were estimated in phase 3, along with the retention parameters and growth parameters ( $K$  and  $L_{min}$ ). Recruitment deviations were estimated in phase 4, followed by  $\sigma_R$  in phase 5.

## 3.5 Model Diagnostics

A wide variety of model diagnostics were implemented and analyzed to evaluate model performance, model fits to the data, model stability, and uncertainty in model parameters and derived quantities.

### **3.5.1 Residual Analysis**

The primary mode used to address model performance and fit was residual analysis of the model fit to each of the datasets. Any temporal trends in model residuals (or trends with size or age for compositional data) can be indicative of model misspecification and poor performance. It is not expected that any model will perfectly fit any of the observed datasets, but, ideally, residuals will be randomly distributed and conform to the assumed error structure for that data source. Any extreme patterns of positive or negative residuals are indicative of poor model performance and potential unaccounted for process or observation error.

### **3.5.2 Correlation Analysis**

High correlation among parameters can lead to flat likelihood response surfaces and poor model stability. By performing a correlation analysis, modeling assumptions that lead to inadequate model parametrizations can be highlighted. Because of the highly parametrized nature of stock assessment models, it is expected that some parameters will always be correlated (e.g., stock-recruit parameters). However, a large number of extremely correlated parameters warrant reconsideration of modeling assumptions and parametrization. A correlation analysis was carried out and correlations with an absolute value greater than 0.7 were reported.

### **3.5.3 Profile Likelihood**

Profile likelihoods are used to examine the change in log-likelihood for each data source in order to address the stability of a given parameter estimate, and to see where each individual data source wants the parameter estimate to be. The analysis is performed by holding the given parameter at a fixed value and rerunning the model. This is done for a range of reasonable parameter values. Ideally, the graph of likelihood value against parameter value will give a well-defined minimum indicating that each data source is in agreement. When a given parameter is not well estimated, the profile plot will show conflicting signals across the data sources. The resulting total likelihood surface will often be flat, indicating that multiple parameter values are equally likely given the data. In such instances, the model assumptions need to be reconsidered as the model is unstable and generally unreliable.

Typically, profiling is carried out for a handful of problematic (and often correlated) parameters, particularly those defining the stock-recruit relationship. Profile likelihoods were done for each of the stock-recruit parameters and the initial fishing mortality estimates for each fishing fleet. Even though steepness was not estimated in the SEDAR61 Base Model, it is important to know the most likely values of this parameter given that it influences the potential productivity of the resource and, therefore, biological reference points. Additionally, there is interest in having steepness be freely estimated and knowing whether the fixed values utilized are supported by the data.

### **3.5.4 Bootstrap**

Parametric bootstrap analysis is a convenient way to analyze model performance and variance estimation. With bootstrapping, the assumed error structure is used to create a new random set of observations using the same variance characteristics as the original data. Because the bootstrapped data strictly conforms to the error distribution and do not include any process error, the resulting fit to the data should be randomly distributed according to the assumed error distribution (i.e., there is no autocorrelation among data points, which is often an issue with observed data; Methot and Wetzel 2013). Therefore, analysis of residual patterns in bootstrapped data can elucidate potentially detrimental modeling assumptions. Similarly, if parameter estimates differ between bootstrap runs and the base model fit to the observed data, it can be indicative of data conflict (similar to flat profile likelihood surfaces). Generally, consistency across bootstrap runs and base model runs indicates that the model is performing well and is relatively stable. Five hundred bootstrap runs were carried out and summary statistics were generated to characterize model performance.

### ***3.5.5 Jitter Analysis***

Jitter analysis is a relatively simple method that can be used to assess model stability and to determine whether a global as opposed to local minima has been found by the search algorithm. The premise is that all of the starting values are randomly altered (or ‘jittered’) by an input constant value and the model is rerun from the new starting values. If the resulting population trajectories across a number of runs converge to the same final solution, it can be reasonably assured that a global minima has been obtained. Of course, this process is not fault-proof and no guarantee can ever be made that the ‘true’ solution has been found or that the model does not contain misspecification. However, if the jitter analysis results are consistent, it provides additional support that the model is performing well and has come to a stable solution. For this assessment, a jitter value of 10% was applied to the starting values and 200 runs were completed.

### ***3.5.6 Retrospective Analysis***

A retrospective analysis is a useful approach for addressing the consistency of terminal year model estimates. The analysis sequentially removes a year of data at a time and reruns the model. If the resulting estimates of derived quantities such as SSB or recruitment differ significantly, particularly if there is serial over- or underestimation of any important quantities, it can indicate that the model has some unidentified process error, and requires reassessing model assumptions. It is expected that removing data will lead to slight differences between the new terminal year estimates and the updated estimates for that year in the model with the full data. Oftentimes additional data, especially compositional data, will improve estimates in years prior to the new terminal year, because the information on cohort strength becomes more reliable. Therefore, slight differences are expected between model runs as more years of data are peeled away. Ideally, the difference in estimates will be slight and more or less randomly distributed above and below the estimates from the model with the complete datasets.

Typically, 5-10 year retrospective analyses are completed. Care must be taken when time blocks exist for selectivity parameters or when there are any short data time series that span only the last few years of the model, because removing a few years of data may cause the model to become unstable when not enough data are available to estimate parameters for these short datasets. The



instability is not a reflection of poor model performance, but simply an issue of overparametrization caused by a short time series. A five year retrospective was carried out.

### ***3.5.7 Jack-knife Analysis on Indices of Abundance***

Another type of data exclusion analysis is the jack-knife approach where individual datasets are removed and the model is rerun with the remaining data. The goal of this analysis was to determine if any single index of abundance was having undue influence on the model and causing tension with other data in terms of estimating parameters. The approach can be especially useful for identifying indices that may be giving conflicting abundance trend signals compared to the other indices. If removing a dataset leads to dramatically different results, it suggests that the dataset should be reexamined to determine if the sampling procedures are consistent and appropriate (e.g., an index may only be sampling a sub-unit of the stock and resulting abundance signals may only reflect a local sub-population and not the trend in the entire stock). Other datasets (i.e., landings and compositional data) were deemed fundamentally necessary to stabilize the assessment and therefore their exclusion was not entertained in the jack-knife analysis.

### ***3.5.8 Continuity Model and Model Bridging Exercise***

The first step in model development was to create a continuity model that attempted to replicate, in as feasible a way as possible, the SEDAR42 Final Model, but using updated values for each of the datasets through a terminal year of 2017. Developing a continuity model is a useful tool for comparing model performance and addressing the impact of any changes in model assumptions. Development of a true continuity model was difficult because substantial improvements in methodology for commercial discards and all recreational data inputs (landings, discards, CPUE, age composition) prevented development of continuity data inputs. Therefore, the SEDAR61 Continuity Model developed is considered the closest representation of a continuity model as possible.

An extensive model building exercise was then undertaken to provide a comprehensive bridge between the SEDAR42 Final Model and the SEDAR61 Base Model. The results were presented in three stages: (1) building to the SEDAR61 Continuity Model, (2) building to a SEDAR61 1993 Base-in-Progress Model, and (3) building and finalizing the SEDAR61 1986 Base Model. The first stage of model building developed the SEDAR61 Continuity Model, which was as similar to the SEDAR42 Final Model as possible (discussed above). The second stage of model building was to obtain a working base model with configuration changes based on best practices (e.g., red tide fleet operation, treatment of sample size for composition data, data weighting, and selectivity parameterizations, among others). The third stage of model building was to develop and finalize the SEDAR61 Base Model starting in 1986, following a recommendation by the SEDAR61 DW/AW Panel to start the model earlier than 1993. Throughout the entire process, a stepwise, single factor approach was undertaken to compare the impact of each factor in isolation during model development. However, given the vast number of changes made and assumptions tested during the model building exercise, only a subset of model runs are presented in this report.

### 3.5.9 Sensitivity Runs

Sensitivity runs were conducted with the SEDAR61 Base Model to investigate critical uncertainty in data and reactivity to modeling assumptions. An exhaustive evaluation of model uncertainty was not carried out, but the aspects of model uncertainty judged to be the most important for model performance and accuracy were investigated. Only the most important sensitivity runs are presented here, but many additional exploratory runs were also implemented. Focus of the sensitivity runs was on population trajectories and important parameter estimates (e.g., recruitment). The runs presented here include years with severe red tide events, removal of groups of indices of relative abundance, and estimation of steepness.

#### Red Tide

Given the discussions at the SEDAR61 DW/AW Workshop related to years with severe red tides and their associated magnitudes, different combinations of years that allowed for red tide mortality were tested to explore the impact on model results:

1. 2005 and 2014 (i.e., SEDAR61 Base Model) – assumes 2014 was a severe event; this decision was based on overwhelming feedback from stakeholders at the meeting and the online voluntary data collection tool sponsored by the Gulf of Mexico Fishery Management Council.
2. 2005 only – assumes the 2014 red tide was not severe enough to warrant estimation of red tide mortality (i.e., baseline levels of red tide mortality in 2014 are already accounted for in the natural mortality vector fixed in the model). This matches the results of the red tide analyses presented in **Sections 2.6.1-2.6.2**, although notable caveats and limitations of these analyses were discussed in detail at the SEDAR61 DW/AW Workshop
3. 2005 and 2015 – assumes a severe red tide occurred in 2015 and not 2014; while the focus of the SEDAR61 DW/AW Workshop was on 2014, with very little mention of the red tide event in 2015, this scenario was included to satisfy the Term of Reference (2D).
4. 2005, 2014, and 2015 – assumes a severe red tide occurred in both 2014 and 2015 in addition to 2005.

#### Removal of Groups of Indices

Progressively more complex regulations implemented in both the commercial and recreational fisheries have made CPUE standardization increasingly difficult. Given that CPUE is less likely to reflect actual abundance or biomass than fishery-independent abundance indices, there was interest in whether removal of all CPUE indices would impact model results. Different groups of indices of relative abundance were removed to explore the impact on population trajectories:

1. No commercial CPUE indices (remove commercial vertical line and longline)
2. No recreational CPUE indices (remove headboat and MRIP charter/private)
3. No fishery-dependent CPUE indices (remove commercial and recreational)
4. No fishery-independent indices (remove Combined Video, SEAMAP Summer Groundfish, NMFS Bottom Longline Survey, and FWRI Hook and Line Repetitive Time Drop Surveys)

#### Steepness

Steepness is generally one of the most uncertain parameters estimated in a stock assessment model and is a critical quantity to stock assessment. During SEDAR42, steepness was originally estimated using an informative symmetric beta prior based on the Shertzer and Conn (2012) meta-analysis. However, during the SEDAR42 Review Workshop, the Panel recommended fixing steepness at 0.99. Given that steepness may be estimable in the SEDAR61 Base Model, as evident by the model diagnostics, we conducted two sensitivity runs:

1. Freely estimate steepness without a prior
2. Estimate steepness using the informative prior of 0.84 from Shertzer and Conn (2012) that was considered during SEDAR42

## 4. MODEL RESULTS

### 4.1 Landings

Given the relatively small standard error assumed for the log of the commercial landings data (0.15) and a relatively larger standard error for the recreational fishery (0.3), these data sources were fit relatively well in the SEDAR61 Base Model (total negative log-likelihood = 36.5; **Figures 4.6-4.7**). With a few notable exceptions discussed below, expected landings were generally similar to observed landings. Prior to the inclusion of discards for the commercial fleets (pre-1993 for vertical line and longline and pre-1990 for trap), the observed and expected landings were nearly identical (**Figure 4.6**). For the commercial vertical line, the SEDAR61 Base Model generally underestimated landings from 1993 through the mid-2000s and slightly overestimated landings for the remainder of the time series (**Figure 4.6**). In contrast, the SEDAR42 Final Model overestimated commercial vertical line landings throughout the entire time series (**Figure 4.6**). For the commercial longline, the SEDAR61 Base Model occasionally overestimated landings in the mid-1990s and consistently overestimated landings from 2006 to 2017, whereas trends in estimation were variable for the SEDAR42 Final Model (**Figure 4.6**). Trends in commercial trap landings were similar between models, as landings were substantially underestimated in 1994 but overestimated in 1996-97 (**Figure 4.6**). Differences in expected recreational landings were evident between models (**Figure 4.7**). The SEDAR42 Final Model generally overestimated landings throughout the time series whereas the SEDAR61 Base Model tended to underestimate recreational landings until 2007 then overestimate landings until 2014 (**Figure 4.7**).

### 4.2 Discards

The SEDAR61 Base Model fit the discard data fairly well (total negative log-likelihood = -30.1). This is in clear contrast to the SEDAR42 Final Model, which exhibited poor fits to discards, particularly for the commercial vertical line fleet (**Figure 4.8**). The updated methodology used to calculate observed commercial discards (**Section 2.3.3**) resulted in much smaller observed discards than those used in SEDAR42 (**Figure 4.8**). For the commercial vertical line discards, the SEDAR61 Base Model frequently overestimated discards until 2009, after which discards were consistently underestimated (**Figure 4.8**). While the trend in estimated commercial longline discards was more variable prior to 2010, the SEDAR61 Base Model generally underestimated

discards after 2010 (**Figure 4.8**). Estimated commercial trap discards were relatively similar between the SEDAR61 and SEDAR42 models, with the exception of the early 2000s where the SEDAR61 Base Model overestimated trap discards (**Figure 4.8**). The observed recreational discards calculated using revised methodologies and calibration procedures for MRIP were much larger in comparison to the discards observed during SEDAR42 (**Figure 4.9**). Trends were generally similar across models, with recreational discards overestimated between 1993 and 1995 and consistently underestimated between 2008 and 2013 (**Figure 4.9**).

### 4.3 Indices

The SEDAR61 Base Model was fit to four fishery-dependent CPUE indices and four fishery-independent indices and generally fit the index data fairly well, although some exceptions were noted (total negative log-likelihood = -102.6). **Figures 4.10-11** show the SEDAR61 Base Model fits in comparison to the SEDAR42 Final Model fits to the standardized indices. Root mean square error (RMSE) estimates are provided to quantify the difference between observed and predicted indices for each model. It is important to note that the extra weighting implemented in the SEDAR42 Final Model upweighted the indices and therefore resulted in improved model fits. Given the different approach to data weighting in SEDAR61, largely the removal of the survey lambdas, fits to the indices and resulting RMSEs are not expected to be identical.

The SEDAR61 Base Model fit to the commercial vertical line standardized index exhibited a higher RMSE than the SEDAR42 Final Model fit, but generally matched the trends of increasing/near constant abundance from 1993 until 2005, declining from 2005 to 2006, and increasing thereafter (**Figure 4.10**). The SEDAR61 Base Model fit to the commercial longline index exhibited a lower RMSE than the SEDAR42 Final Model fit, and similarly predicts the same trend as the commercial vertical line (**Figure 4.10**). The SEDAR61 Base Model fits underestimated the peak index observed in 2005 for both fleets (**Figure 4.10**).

The SEDAR61 Base Model fits to both the standardized headboat and MRIP charter/private indices showed larger RMSE estimates compared to the SEDAR42 Final Model fits, although it is important to note the use of the full time series in the SEDAR61 Base Model. Overall, the trends in relative abundance for the headboat index were similar, with both the SEDAR61 and SEDAR42 models predicting relatively small increases in abundance from the early 1990s until 2004, with a noticeable decline after 2005 following the severe red tide event (**Figure 4.10**). As observed above for the commercial longline index, both the SEDAR61 and SEDAR42 model fits underestimated peak relative abundance in 2005. Predicted relative abundance remains low between 2006 and 2009, increases until 2012, and declines steadily until 2017 (**Figure 4.10**). The SEDAR61 Base Model fit to the standardized MRIP charter/private index is relatively flat between 1986 and 2000, missing the observed changes in the index during this period. While the selectivity of the MRIP charter/private survey is mirroring the recreational fishery, the expected CPUE does not use the retention curve and therefore does not account for discards (Methot et al. 2018), which were included in the development of the observed index. The SEDAR61 Base Model predicts an increase in abundance from 2000 through 2004, a decrease from 2005 to 2007, an increase until 2010, and a decline from 2010 until 2015 (**Figure 4.10**).

The SEDAR61 Base Model resulted in a substantially lower RMSE for the standardized index for the Combined Video Survey compared to the SEDAR42 Final Model, with predicted relative abundance fairly similar to observed relative abundance in terms of trend and magnitude (**Figure 4.11**). The SEDAR61 Base Model predicted a gradual increase between 1993 and 2004, matching the observed index values almost exactly for some years. Predicted relative abundance declined between 2004 and 2006, remained relatively stable between 2006 and 2008 (overestimating relative abundance in 2007), increased from 2008 to 2011, and declined until 2015 (**Figure 4.11**). The SEDAR61 Base Model predicted the lowest abundance of the time series between 2015 and 2017, which captures the lowest observed index value in 2015.

Fits to the standardized index from the NMFS Bottom Longline Survey and RMSEs were relatively similar between the SEDAR61 Base and SEDAR42 Final Models. The predicted abundance by both models increases between 2001 and 2004, declines until 2006, remains relatively stable between 2006 and 2008, increases to a peak in 2012 (a year after the observed peak), and declines gradually until 2017. As documented for the Combined Video Survey above, the SEDAR61 Base Model predicted the lowest abundance of the time series between 2015 and 2017, which captures the lowest observed index value in 2016 (**Figure 4.11**). However, the predicted index underestimates the peak in abundance that was observed in 2011 and 2012.

The SEDAR61 Base Model fit to the index of abundance from the SEAMAP Summer Groundfish Survey showed a larger RMSE compared to the SEDAR42 Final Model fit, although it is important to note the length of the time series nearly doubled for SEDAR61. Both models predicted a decrease in abundance from 2009 through 2013, although the SEDAR61 model underestimates abundance in both 2009 and 2012 (**Figure 4.11**). For the SEDAR61 Base Model, predicted abundance remained low but relatively stable since 2013, with the lowest predicted abundance occurring in 2014. The lowest observed abundance occurred in 2017.

While relatively few years of data are available for the index of abundance from the FWRI Hook and Line Repetitive Time Drop Survey, the model generally matches the trend in observed abundance. The predicted index declines between 2014 and 2015, remains relatively constant between 2015 and 2016, and increases slightly in 2017 (**Figure 4.11**). While the observed index reaches a minimum value in 2017, the SEDAR61 Base Model predicted the lowest abundance in 2015.

#### 4.4 Size Composition

The SEDAR61 Base Model and SEDAR42 Final Model fits to the length composition data associated with the discard series and fishery-independent surveys are presented in **Figures 4.12-15** and **4.17-20**. Pearson residuals for each fleet and data type are shown in **Figures 4.16** and **4.21**.

The quality of the fit varied among the fleets and surveys, and aggregate fits were generally improved in the SEDAR61 Base Model (total negative log-likelihood = 287.3) compared to the SEDAR42 Final Model (**Figure 4.12**). In particular, the SEDAR61 Base Model fits to the discard length compositions were much more similar to observed distributions, largely due to the changes in retention and selectivity parameterizations (see **Sections 3.3.7-3.3.8**). Similarly, the

peaks in predicted distributions for the Combined Video Survey and SEAMAP Summer Groundfish Survey were more similar to observed peaks in the SEDAR61 Base Model (**Figure 4.12**).

The SEDAR61 Base Model fits to the commercial vertical line discard length composition were generally more in line with observed composition compared to the SEDAR42 Final Model fits, largely due to the changes in how selectivity and retention were modeled (see **Sections 3.3.7-3.3.8**). The peak of the distributions for each year were generally similar between predicted and observed distributions for the SEDAR61 Base Model, whereas the SEDAR42 Final Model tended to overestimate the peak of the distributions (**Figure 4.13**). Similarly, the SEDAR61 Base Model fits to the commercial longline discard length composition were much more similar to the observed distributions compared to the SEDAR42 Final Model fits, although the SEDAR61 model did have a tendency to underestimate the peak in a few years (**Figure 4.14**). The Pearson residuals indicate relatively large residuals in 2009 for both the commercial vertical line and longline fleets (**Figure 4.16**), a year which corresponds to a change in size limit mid-way through the year.

Overall, the recreational discard length composition exhibited considerably improved fits in the SEDAR61 Base Model compared to the SEDAR42 Final Model (**Figure 4.15**). However, noticeable lack of fits were still evident in the SEDAR61 Base Model, particularly during the first few years. The Pearson residuals indicate that there is a fair bit of noise in the SEDAR61 Base Model fit to the data for recreational discard length composition (**Figure 4.16**), likely due small sample sizes of larger individuals.

The SEDAR61 Base Model fits to the length composition data for the Combined Video Survey were variable, with peaks in predicted distributions sometimes underestimating observed distributions (e.g., 2010) and sometimes overestimating observed distributions (e.g., 2014) (**Figure 4.17**). However, peaks in predicted distributions were generally close to peaks in observed distributions, and similar behavior was evident in the SEDAR42 Final Model. The Pearson residuals did not exhibit any systematic patterns, suggesting satisfactory fits (**Figure 4.21**).

Similar trends in SEDAR61 Base Model fits were evident for the length composition in the SEAMAP Summer Groundfish Survey (**Figure 4.18**), with peaks in predicted distributions generally close to peaks in observed distributions. The SEDAR61 Base Model tended to overestimate the peak in predicted distributions in many years, with the exception of 2014 where the model predicted a peak in length composition at the smallest sizes. No clear patterns were observed in the Pearson residuals, and residuals were much improved compared to the SEDAR42 Final Model (**Figure 4.21**).

The SEDAR61 Base Model fits to the length composition data for the NMFS Bottom Longline Survey were relatively good, and were similar to the SEDAR42 Base Model fits, with peaks in predicted distributions often coinciding with or directly adjacent to observed distributions (**Figure 4.19**). In a few years, the SEDAR61 Base Model predicted similar magnitudes in peak predicted and observed distributions (e.g., 2001, 2017), whereas in many years the peak was

underestimated (e.g., 2005) but seldom overestimated (e.g., 2011). As above, no clear patterns were observed in the Pearson residuals (**Figure 4.21**).

Fits to the length composition data for the FWRI Hook and Line Repetitive Time Drop Survey were relatively close to the observed composition for the SEDAR61 Base Model, with peaks in predicted distributions coinciding with observed distributions (**Figure 4.20**). The predicted distributions often underestimated the magnitude of the peak of the observed distribution. Clear patterns were also lacking in the Pearson residuals (**Figure 4.21**).

#### 4.5 Age Composition

The SEDAR61 Base Model and SEDAR42 Final Model fits to the age composition data associated with the landings are presented in **Figures 4.22-26**. Pearson residuals for each fleet and data type are shown in **Figure 4.27**. The quality of the fit varied among the fleets, and aggregate fits across fleets were generally similar between SEDAR61 (total negative log-likelihood = 335.5) and SEDAR42 (**Figure 4.22**). There was a tradeoff in fitting the discard length compositions and the age compositions in the SEDAR61 Base Model, as evident by slightly worse aggregate fits to the commercial longline and recreational age compositions in the SEDAR61 Base Model, while observing better fits to the discard length compositions for these fleets (see **Section 4.4**).

Fits to the commercial landings age composition for the vertical line were relatively similar between the SEDAR61 Base Model and the SEDAR42 Final Model, as predicted peaks often correspond to observed peaks, albeit not at the same magnitude (**Figure 4.23**). There are years where both models underestimate the magnitude of peak distributions (e.g., 2011-2013) and years where the bimodal distribution of the observed data is not accurately captured in the model predictions (e.g., 1991, 1998-2000). In addition, a few of the earlier years (1993, 1994, and 1998) show relatively poor fits to the ascending limb, potentially due to reduced sample sizes. Slight patterns in the Pearson residuals for the vertical line provide evidence that the cohorts tracked in the observed data are not being accurately predicted and are being underestimated (**Figure 4.27**). However, the residual patterns are improved over the patterns displayed by the SEDAR42 Final Model.

The SEDAR61 Base Model fits to the age composition data for the commercial longline are also relatively good in most years, and are similar to the SEDAR42 Final Model fits (**Figure 4.24**). The fits to the longline age composition also shows years with underestimated peaks (e.g., 1999, 2012) and years with lack of fit to observed binomial distributions (e.g., 1995-1996). The observable patterns in Pearson residuals for the longline fleet are less pronounced than for the vertical line fleet and compared to the SEDAR42 Final Model patterns (**Figure 4.27**).

Both SEDAR61 Base Model and SEDAR42 Final Model fits revealed relatively marginal fits to the age composition derived from landings in the trap fishery (**Figure 4.25**). For the majority of years, the peak in predicted distribution is at or near the observed peak, but is often underestimated in magnitude. It is important to note the relatively low sample sizes of age composition observations for the trap fishery. There are fewer systematic patterns in the Pearson residuals for fits to the trap data than the other commercial fleets (**Figure 4.27**).

Fits to the recreational age composition data are relatively similar between the SEDAR61 Base Model and SEDAR42 Final Model (**Figure 4.26**). In general, the recreational age composition has relatively low samples sizes and the distributions of ages each year are irregular and jagged. The Pearson residuals for the recreational fleets show that there is some evidence of cohorts that are not being accurately predicted by the model, particularly for the 1998 and 2005 cohorts (**Figure 4.27**). However, as discussed above, the Residual patterns are less pronounced in the SEDAR61 Base Model compared to the SEDAR42 Final Model.

#### 4.6 Fishery Selectivity and Retention

The selectivity functions for fishing fleets were re-parametrized to be size-based in the SEDAR61 Base Model rather than age-based as in the SEDAR42 Final Model. Estimated length-based selectivity patterns are illustrated for each fishing fleet in **Figure 4.28**. Red Grouper were fully selected for at smaller sizes for the recreational fishery compared to the commercial fisheries (**Figure 4.28**). Red Grouper were generally selected between 45 and 70 cm FL for the commercial vertical line fishery, between 42 cm and 82 cm FL for the commercial longline fishery, between 42 and 75 cm FL for the commercial trap fishery, and between 30 and 55 cm FL for the recreational fishery (**Figure 4.28**).

The age-based selectivity derived from length-based selectivity for each fishing fleet is shown for the SEDAR61 Base Model and compared to the age-based selectivity used in the SEDAR42 Final Model. All fisheries were estimated to have a dome-shape in both models. Using age-based selectivity in the SEDAR42 Final Model resulted in a more dome-shaped selectivity pattern for the commercial longline fleet, whereas the level of dominess was similar between models for the remaining fleets (**Figure 4.29**). None of the selectivity patterns of the SEDAR61 Base Model reached full selection (i.e., 1.0), as the commercial vertical line and recreational selectivity patterns peak around 0.8 while the commercial longline and trap selectivity patterns peaks around 0.9. The estimated selectivity patterns illustrate that the recreational fleet selects younger Red Grouper (4-9 years) than the commercial fleets, with age at full selection estimated at 7 years in the SEDAR42 Final Model and the most selected age at 6 years in the SEDAR61 Base Model (**Figure 4.29**). The commercial vertical line tends to land fish between 7 and 15 years, with peak selection at 10 years in the SEDAR61 Base Model and 7 years in the SEDAR42 Final Model (**Figure 4.29**). The commercial trap fishery up until 2006 generally landed fish aged 6 and older, with an age at full selection estimated at 9 years in the SEDAR42 Final Model and near-full selection at 10 years in the SEDAR61 Base Model (**Figure 4.29**). The commercial longline landed the oldest fish (ages 6+), with the SEDAR61 Base Model estimated nearly full selection between 11 and 12 years in contrast to the pattern estimated in the SEDAR42 Final Model, which was very jagged with full selection around 4 years (**Figure 4.29**).

The length-based selectivity patterns for the fishery-independent surveys estimated in the SEDAR61 Base Model revealed some differences from the patterns estimated in the SEDAR42 Final Model (**Figure 4.30**). The Combined Video Survey selectivity pattern estimated in the SEDAR42 Final Model was essentially asymptotic, with three of the six parameters showing CVs much larger than 1. To improve model stability and reduce overparametrization, a logistic selectivity pattern was used for the SEDAR61 Base Model. The size at 50% inflection was



estimated at 43 cm FL ( $CV = 0.05$ ) in the SEDAR61 Base Model (**Table 4.1**), and slightly larger than the size of 50% selectivity for the SEDAR42 pattern. Red Grouper are fully selected above 70 cm FL in the SEDAR61 Base Model, which is roughly 10-15 cm larger than the estimate from SEDAR42 (**Figure 4.30**).

The SEAMAP Summer Groundfish Survey selectivity pattern was estimated to be dome-shaped in both models using a double normal pattern (**Figure 4.30**). The selectivity pattern for the SEDAR42 Final Model showed a very sharp increase on the ascending side of the selectivity curve, with this parameter exhibiting a high correlation with the peak parameter and a  $CV$  exceeding 1. For the SEDAR61 Base Model, selection gradually increased to full selection between 25 cm FL and 35 cm FL and declined thereafter (**Figure 4.30**).

The selectivity pattern for the NMFS Bottom Longline Survey was re-parametrized using a logistic function in the SEDAR61 Base Model to improve model stability and help reduce the overparametrization of the model. In the SEDAR42 Final Model, the estimated selectivity pattern was essentially asymptotic over the range of observed sizes in the length composition data (**Figure 4.30**). The size at 50% inflection was estimated around 43 cm FL ( $CV = 0.05$ ) in the SEDAR61 Base Model (**Table 4.1**), which is a few cm FL larger than the size of 50% selectivity for the SEDAR42 Final Model. Red Grouper are fully selected above 60 cm FL in the SEDAR61 Base Model, whereas full selection occurred from sizes above 50 cm FL in the SEDAR42 Final Model (**Figure 4.30**).

For the SEDAR61 Base Model, the selectivity pattern of the MRIP charter/private survey was mirrored to the recreational fleet selectivity, and generally selected for Red Grouper between 30 cm FL and 55 cm FL (**Figures 4.29-4.30**).

For the SEDAR61 Base Model, selectivity of the FWRI Hook and Line Repetitive Time Drop Survey was parametrized using a logistic function (**Figure 4.30**) since this survey covers key adult Red Grouper habitat and encounters a variety of sized individuals. The size at 50% inflection was estimated around 35 cm FL ( $CV = 0.03$ ; **Table 4.1**), with full selection above 50 cm FL (**Figure 4.30**).

Fleet-specific length-based selectivity and retention patterns, and the assumed discard mortality rates are illustrated in **Figures 4.31-4.34**. Length-based time-varying retention functions (logistic in form) were modeled for the commercial and recreational fisheries to account for the changes in the size of fish retained due to changes in size limits (see **Section 3.3.8**). For the commercial vertical line (**Figure 4.35**), longline (**Figure 4.36**) and trap (**Figure 4.37**), all Red Grouper caught prior to 1990 were assumed to be retained. As expected, reductions in the minimum size limit from 20 to 18 inches TL in 2009 resulted in the retention of smaller Red Grouper by the commercial vertical line (**Figure 4.35**) and longline (**Figure 4.36**) fisheries, while Red Grouper below the size limit were generally discarded. The SEDAR42 Final Model estimated the asymptotes for the commercial vertical line and longline fleets near the maximum and the inflection points slightly above the size limit for the most recent 2009-2013 time block (**Figure 4.35-4.36**). To improve model stability, these parameters were re-evaluated (see **Section 3.3.8**) and fixed within the SEDAR61 Base Model. For the SEDAR61 Base Model, all retention

parameters were fixed for the commercial trap due to the lack of discard length composition, whereas no time-varying retention was included in the SEDAR42 Final model (**Figure 4.37**).

Due to a start year of 1993 in the SEDAR42 Final Model, no time-varying retention at length was included for the recreational fishery. In the SEDAR61 Base Model, estimating the asymptote allowed for the discarding of legal size Red Grouper due to bag limits and other management regulations. The SEDAR61 Base Model estimated the asymptote at 1.29 ( $CV = 0.32$ ; **Table 4.1**), which led to the retention of roughly 80% of Red Grouper above the size limit (**Figure 4.38**).

#### 4.7 Recruitment

The two leading parameters for defining the stock-recruitment relationship were steepness and virgin recruitment ( $R_0$ ). Based on the assumptions utilized in SEDAR42, the stock-recruit steepness was fixed at 0.99 and  $R_0$  was estimated. The estimated value of the virgin recruitment in log-space,  $\ln(R_0)$ , was 9.925 ( $SD = 0.035$ ; **Table 4.1**), which equates to 20.4 million age-0 recruits.

The plot of the spawner-recruit relationship estimated by the SEDAR61 Base Model (assuming a steepness = 0.99 and  $\sigma_R$  estimated at 0.815) shows high recruitment associated with years 2005, 1998, 2001, 2013, and 1995 (**Figure 4.39**). These years were also identified in the SEDAR42 Final Model, and agree with the cohort structure seen in the age composition data associated with landings for fishing fleets (**Figures 4.23-4.26**). Both high and low levels of recruitment are predicted across the range of spawning biomass values, resulting in an essentially flat (due to the steepness being fixed near 1.0) curve with estimated recruitments varying widely with no strong trends about the curve (**Figure 4.39**). This lack of a relationship was also evident in the SEDAR42 Final Model which made the same assumption about steepness. The SEDAR61 Base Model identified the largest recruitment events being associated with relatively large SSB in 2005 and 2013 and relatively moderate SSB in 1995, 1998 and 2001 (**Figure 4.39**).

Recruitment estimates have fluctuated without apparent trend since 1993 when age composition data became available (**Figure 4.40**). The highest estimated recruitment occurred in 2005, followed by 1998, 2001, 2013, and 1995. These higher average recruitments are generally preceded and followed by relatively low average recruitments. Recruitment has remained relatively low in the last few years, with the last relatively large recruitment event occurring in 2013. The age composition data provides evidence of strong year classes moving through the different fisheries. For example, the 2005 year class was evident from 2011 and subsequent years in the commercial vertical line (**Figure 4.23**) and longline (**Figure 4.24**) fisheries. No clear patterns in recruitment deviations were evident (**Figure 4.40**). Initial attempts at estimating early recruitment deviations (i.e., pre-1993) in the SEDAR61 Base Model led to highly uncertain recruitment deviations (i.e.,  $CV > 1$ ) and model instability (including virgin conditions). As a result, early recruitment deviations were not estimated and instead fixed at 0. The early recruitment deviations in the SEDAR42 Final Model prior to 1986 did not differ significantly from zero (**Figure 4.40**).

#### 4.8 Red Tide

The estimated mortality rates from the red tide events in 2005 and 2014 were 0.339 ( $CV = 0.309$ ) and 0.257 ( $CV = 0.429$ ), respectively (**Table 4.1**). These mortality rates corresponded to dead biomass of Red Grouper totaling 29.5% and 21.3% of the population in 2005 and 2014, respectively.

#### 4.9 Population Trajectories

Predicted total biomass and spawning output in eggs are summarized in **Table 4.2** and **Figure 4.41**. Total biomass declined slightly between 1986 and 1990 and remained fairly stable at relatively low levels between 1990 and 1995 (**Figure 4.41**). Total biomass gradually increased from 1995 until 2005 and declined sharply in 2006, largely the result of the 2005 red tide event. From 2006 to 2012, total biomass gradually increased and revealed another sharp decline between 2014 and 2015, again hypothesized as a result of a severe red tide event. Since 2015, total biomass has remained at the lowest levels in the time series (**Figure 4.41**). The trend in total biomass for the SEDAR42 Final Model is generally similar, and reveals the highest total biomass in 2012 and 2013 (**Figure 4.41**). The trend seen in total biomass is also evident in the predicted spawning output (**Figure 4.42**).

The predicted numbers-at-age and mean age are presented in **Figure 4.43** and are similar to trends predicted by the SEDAR42 Final Model. The predicted numbers-at-age indicate that two strong recruitment events were predicted in 1998 and 2005, with other relatively strong recruitment events in 1995, 2001 and 2013. Mean age varied between two and three years between 1986 and 1996 and then declined to one year in 1998 (**Figure 4.43**). Between 1998 and 2004, mean age varied between one and three years, declining in 2005 to one year due to the strongest recruitment event in the time series (**Figure 4.43**). Predicted mean age steadily increased until peak mean age (3-4 years) between 2010 and 2012, declined to two years in 2013 and has remained between two and three years until 2017 (**Figure 4.43**).

#### 4.10 Fishing Mortality

The fraction of the stock killed by fishing (i.e., harvest rate in biomass killed by fishing / total biomass at the beginning of the year) was used as the proxy for annual fishing mortality rate. Predicted annual harvest rate estimates (all fleets combined) are presented in **Table 4.3** and **Figure 4.44**. Fleet-specific fishing mortality rates (i.e., instantaneous apical rates representing the fishing mortality level on the most vulnerable age class) are presented in **Table 4.4** and **Figure 4.45**. Trends in annual fishing mortality showed a gradual increase from 1987 through 1993 with the exception of a relatively large peak in 1989 (**Figure 4.44**) due to a spike in recreational fishing mortality (**Figure 4.45**). Between 1993 and 2010, a cyclical trend of declining fishing mortality was evident starting in 1993, 1999, and 2004, with the exception of peak fishing mortality in 2005 which included red tide mortality estimated in 2005 (**Figure 4.44**). Fishing mortality increased from 2010 to 2014, with high predicted fishing mortality in 2014 due to red tide mortality estimated in this year, and declined from 2015 to 2017 (**Figure 4.44**).

The main source of fishing mortality from the SEDAR42 Final Model was the commercial longline fishery, where fishing mortality peaked above 0.6 in the early 1990s and declined throughout much of the time series to 0.1 in 2013 (**Figure 4.45**). In contrast, the main source of fishing mortality in the SEDAR61 Base Model is the recreational fishery (**Figure 4.45**), largely due to the revised and improved methodology for MRIP (see **Section 2.4**). Fishing mortality for the recreational fleet remained fairly variable between years, ranging from below 0.2 in 1987 and 1996 to above 0.8 in 1989 and 2014, whereas in the SEDAR42 Final Model it varied between 0.1 and 0.2 and only exceeded other fleets in 2009 and 2013 (**Figure 4.45**). While the overall trend in fishing mortality for the commercial longline fleet was similar between the SEDAR61 and SEDAR42 models, predicted fishing mortalities in the SEDAR61 Base Model were much lower (**Figure 4.45**). Fishing mortality increased from about 0.1 in 1986 to a peak of approximately 0.3 in 1993, declined to below 0.1 in 2010, and increased to 0.2 in 2016 (**Figure 4.45**). Fishing mortality for the commercial vertical line fishery remained relatively low in both models, ranging from about 0.1 to 0.3 in the SEDAR61 Base Model and 0.05 to 0.18 in the SEDAR42 Final Model (**Figure 4.45**). Trends were similar across models, with commercial vertical line fishing mortality peaking in the early 1990s, declining until 1998, and remaining relatively stable with slight increases in 2000, 2009 and 2015 (**Figure 4.45**). Fishing mortality for the commercial trap fishery ranged between 0 and 0.1 in the SEDAR61 Base Model and 0 and 0.16 in the SEDAR42 Final Model, with declines noted from 1995 through 1998 and 2000 through 2006 (**Figure 4.45**).

#### 4.11 Measures of Uncertainty

The estimated parameters and derived quantities as well as the Stock Synthesis estimated asymptotic standard errors are provided in **Table 4.1**. Most parameter estimates appear reasonable and coefficients of variation (*CV*; standard error divided by parameter estimate) were low indicating relatively well estimated parameters. Exceptions were noted for recruitment deviations, particularly for more recent years where *CVs* ranged between 1 and 2.

Given the highly parametrized nature of this model, a few of the parameters were mildly correlated (correlation coefficient > 70%) however no strong correlations (> 95%) were evident. Initial fishing mortality estimates and recruitment deviations occasionally demonstrated minor autocorrelation (**Table 4.5**). The estimated von Bertalanffy growth coefficient (*K*) was also moderately correlated with the length at the minimum age (*L<sub>min</sub>*). Correlation among these parameters is not surprising, especially for the selectivity parameters, because the parameters of selectivity functions are inherently correlated (i.e., as the value of one parameter changes the other value will compensate). Moderate correlations occurred in some cases, particularly between the parameter defining the peak of the double normal selectivity function and the parameter defining the width of the ascending limb of the double normal function. Where necessary, priors were used on selectivity parameter estimates to help stabilize the SEDAR61 assessment model (see **Section 3.3.7**).

#### 4.12 Diagnostic Runs

##### 4.12.1 Profile Likelihoods

The total likelihood component from the  $\text{Ln}(R_0)$  likelihood profile indicates that the global solution for this parameter is approximately 9.9 (**Figure 4.46**), with the SEDAR61 Base Model estimating  $\text{Ln}(R_0)$  at 9.925 ( $CV = 0.004$ ; **Table 4.1**). While some likelihood components support this estimate, the discard data support a slightly lower estimate around 9.8, the equilibrium catch data supports values between 10 and 10.2, and the index data supports higher estimates around 10.4. Although not estimated in the SEDAR61 Base Model, the total likelihood component from the steepness likelihood profile indicates that the global solution for this parameter is between 0.74 and 0.76, although conflicts between data sources are evident (**Figure 4.47**). The catch and index data components favor values around 0.6 whereas the discard and length composition components favor values above 0.9. The total likelihood component from the recruitment variability likelihood profile supports values around 0.8 (**Figure 4.48**), with the SEDAR61 Base Model estimating  $\text{Sigma}R$  at 0.815 ( $CV = 0.136$ ; **Table 4.1**). However, the catch and discard data components favor  $\text{Sigma}R$  around 0.4 whereas the length composition components favor a  $\text{Sigma}R$  above 0.7.

Across the range of parameter values tested in the various profile likelihood runs, the model provided similar trends in relative SSB estimates (**Figure 4.49**). Terminal year estimates in relative SSB appear relatively consistent across parameter values, with some divergence for the steepness parameters (that are likely less realistic for Red Grouper). In general, the model appears somewhat robust to the values of the stock-recruit parameters.

The total likelihood component from the initial fishing mortality rate for the commercial vertical line likelihood profile indicates that the global solution for this parameter is between 0.12 and 0.13 (**Figure 4.50**), with the SEDAR61 Base Model estimating a value of 0.129 ( $CV = 0.187$ ; **Table 4.1**). The catch and discard data components favored lower estimates, while the age composition component favored higher estimates ( $> 0.2$ ). Similar conflicts were observed for the likelihood profile from the initial fishing mortality rate for the commercial longline, which favored a global estimate around 0.09 (**Figure 4.51**), which was similar to the model estimate of 0.09 ( $CV = 0.2$ ; **Table 4.1**). Both the total likelihood component and the various components favored an initial fishing mortality rate for the commercial trap around 0.02 (**Figure 4.52**), which was estimated by the SEDAR61 Base Model at 0.019 ( $CV = 0.219$ ; **Table 4.1**). Conflicts between data sources were evident for the initial fishing mortality rate for the recreational fishery, where the total likelihood component supported values between 0.23 and 0.26 (**Figure 4.53**), while the SEDAR61 Base Model estimated a value of 0.245 ( $CV = 0.204$ ; **Table 4.1**). High initial fishing mortality rates were supported by the age data, whereas low estimates were favored by the discard and catch data components.

Across the range of initial fishing mortality values tested for each fleet in the profile likelihood runs, the model provided similar trends in estimated SSB starting around 1995 (**Figure 4.54**). Terminal year estimates in relative SSB appear relatively consistent across parameter values, whereas initial year estimates showed the highest variability due to different starting conditions determined by the fixed initial fishing mortality rates. In general, the model appears somewhat robust to the values of initial fishing mortality estimates for the various fleets.

#### 4.12.2 Bootstrap Analysis

Results of the 500 bootstraps indicate that the model performed fairly well and was relatively stable, because parameter estimates for the runs fit to the bootstrapped datasets tended to converge towards the same solutions as the SEDAR61 Base Model fit to the observed data (**Figure 4.55**). Exceptions were noted for the terminal year recruitment where the SEDAR61 Base Model estimate fell below the 50% confidence interval (**Figure 4.55**). The trend in recruitment may result from the variability observed in the SEDAR61 Base Model estimated  $\text{SigmaR}$ , where the model estimate of 0.8 was slightly higher (and just outside the 50% confidence interval) than the range of values obtained from the bootstrap analysis. The bootstrap analysis also revealed some variability in the initial fishing mortality rates for each fishery, where the SEDAR61 Base Model estimates from the observed dataset often fell outside the 50% confidence interval of the fits to bootstrapped datasets (**Figure 4.56**). It is important to note that the initial fishing mortality is largely dependent on the bootstrapped age composition data, and it is possible that the bootstrapped dataset is not representing reality (i.e., bootstrapped data may not be as poor as observed). Closer inspection of the terminal year harvest rate by fleet showed that the model estimate fell within the 50% confidence intervals for each fleet (**Figure 4.56**).

#### ***4.12.3 Retrospective Analysis***

Results of the retrospective illustrate a fairly consistent trend estimated within the SEDAR61 Base Model. As data are peeled off, the model estimates of spawning biomass in each successive terminal year do not change by a large margin (and remain within the confidence intervals) and show no pathological trend of over or underestimation (**Figure 4.57**). Recruitment estimates, particularly in more recent years, are more variable with some peels demonstrating underestimation (e.g., 2013 recruitment). However, this trend in 2013 is not unexpected, because as additional years are removed, the model is missing key composition data inputs that capture those cohorts moving through the fishery.

#### ***4.12.4 Jitter Analysis***

The jitter analysis indicated that all 200 runs landed on the same negative log-likelihood estimate of 537.486, suggesting a stable model given the current model configuration (**Figure 4.58**).

#### ***4.12.5 Index Jack-knife Analysis***

The results of the index jack-knife analysis, which ran the model with one index removed at a time, indicated that no one index appeared to be having undue influence on the assessment results in most years (**Figure 4.59**). Some years revealed some sensitivity to index removal, although the resulting trends still remained within the uncertainty intervals. Removal of the MRIP charter/private index caused an exaggerated increase in SSB from 2000 through 2005, whereas the removal of the headboat index reduced the absolute estimate of SSB during this same interval. This result is also evident in the fishing mortality trends (**Figure 4.59**), and similar behavior was noted for the SEDAR42 Final Model. The removal of the Combined Video Survey led to slightly higher SSB between 2010 and 2014. No major differences were noted in the estimates of the age-0 recruits when each index was removed (**Figure 4.59**).

#### ***4.12.6 Continuity Model Comparison***

The SEDAR42 Final Model and the best approximation of the SEDAR61 Continuity Model demonstrated differing trends in SSB, recruitment, and fishing mortality (**Figure 4.60**). These differences stem from the lack of continuity data streams for the commercial discards and recreational data inputs which were produced using improved methodology and are quite different from their counterpart SEDAR42 inputs. Although the trends in SSB were very similar, the SEDAR61 Continuity Model displayed much higher SSB than the SEDAR42 Final Model, particularly from 2006 to 2013. Recruitment differed considerably between 2006 and 2012, due in part to the exclusion of length composition data from the SEAMAP Groundfish Survey during fall in the SEDAR61 Base Model (which were erroneously included in the SEDAR42 Final Model). In addition, variability in recruitment remained very high ( $\text{Sigma}R > 1$ ; **Table 4.6**). Fishing mortality was slightly higher in most years for the SEDAR42 Final Model (**Figure 4.60**). Trends in SSB, recruitment and fishing mortality using Stock Synthesis version 3.24 and version 3.3 were indistinguishable (**Figure 4.60**), and model performance was identical between versions (details provided in **Table 4.6**).

An important correction made since the SEDAR42 Final Model was the calculation of input initial equilibrium catches, which were too high in the SEDAR42 Final Model. Initial equilibrium catch was approximated for SEDAR61 as the average catch in the first five years of the modeled time series (i.e., 1993-1997 or 1986-1990 depending on start year), and this modification leads to a considerable change in SSB and initial recruitment (**Figure 4.60**). The drastic difference can be attributed to changes in both virgin SSB and  $R_0$ , which were both noticeably higher in the SEDAR42 Final Model (**Table 4.6**; **Figure 4.60**) but not in the SEDAR42 AW Model (initial equilibrium catches were not in error as an average was used). By inputting overestimated starting catches in the SEDAR42 Final Model, the model required more initial biomass to sustain the catches.

Due to the vast number of runs exploring and fine-tuning model configuration throughout base model development, only a subset of the steps followed in the stepwise model building approach are shown (**Table 4.61**). The second stage of model building focused on working towards a base model starting in 1993. Changes to data included updating data inputs based on improvements in methodology for the Combined Video Survey index of relative abundance and length composition, recreational age composition, growth (and  $M$  which uses the growth curve), and the fecundity vector. The notable difference in SSB between the SEDAR61 Initial Update and the consecutive steps are mainly due to the change in the fecundity vector discussed in **Sections 2.2.5.3 and 3.3.1**. Trends in recruitment and fishing mortality were very similar between the SEDAR61 Initial Update, SEDAR61 Data Update, and SEDAR61 New Data Model (**Figure 4.61**). More advanced model runs including the SEDAR61 Base Model in Progress (AW3 and AW4) revealed more divergent trends in SSB, recruitment and fishing mortality. Both 1998 and 2005 showed considerable variability in recruitment, with lower estimated recruitment events for the more advanced models (**Figure 4.61**). In addition, the more advanced models estimated lower red tide mortality in 2005 and higher red tide mortality in 2014 (**Figure 4.61**). These results likely stem from a combination of changes made including the treatment of input sample sizes for the composition data, the implementation of Francis reweighting of the composition data, and the removal of the extra weight given to indices in the SEDAR42 Final Model. Since best practices iterative reweighting procedures were followed during SEDAR61, the DW/AW

Panel supported the removal of the extra lambda on the indices in the SEDAR42 Final Model that had been implemented to upweight the fits to the indices.

In the third stage of model building, the SEDAR61 1993 Base in Progress (AW4) was modified to start in 1986, following the recommendation of the SEDAR61 DW/AW Panel after observing similar model results but improved model stability for the model starting in 1986. Trends in SSB and recruitment were relatively similar across model runs, although the SEDAR61 1986 Base (AW5) revealed less variable virgin SSB and different recruitment patterns (**Figure 4.62**). It is important to note that the modifications to the SEDAR61 Base in Progress following AW4 included fine tuning the selectivity patterns to better fit cohorts moving through the composition data, hence the model was better able to estimate recruitment deviations. Larger differences were also noted in the estimated fishing mortality between model runs, with higher fishing mortality estimated by the SEDAR61 1986 Base (AW5) (**Figure 4.62**).

The final SEDAR61 Base Model utilizes the recommended practices for each of the updated data sources as identified by the SEDAR61 DW/AW Panel, provides improved fits to the various data sources, and reveals much improved diagnostics and model stability. As such, the SEDAR61 Base Model is the most appropriate model for the basis of management advice from the suite of models investigated.

#### **4.12.7 Sensitivity Model Runs**

Three sensitivity runs were carried out for SEDAR61 including: (1) start year (see **Section 4.12.6**); (2) varying years with severe red tide events; and (3) removal of fishery-dependent indices of relative abundance (**Table 4.7**).

##### Red Tide Years

Overall, the operation of the red tide fleet across different years had a small impact on the spawning output and recruitment (**Figure 4.63**). Annual trends in SSB were relatively similar across scenarios, with terminal SSB nearly identical across scenarios (**Figure 4.63**). Slight shifts in SSB were noted between 2005 and 2014, where the 2005 red tide only model estimated lower overall SSB during that period. Recruitment was also relatively similar across scenarios, with the exception of slightly lower recruitment estimates starting in 2008 and lasting until 2014 for the 2005 only red tide model, as well as a slightly higher terminal recruitment estimate (**Figure 4.63**). The magnitude of the 2005 red tide event was consistently estimated across red tide scenarios at around 0.34, with CVs ranging between 0.31 and 0.32 (**Table 4.8**). When red tide mortality was included in 2005, 2014, and 2015, the model was unable to distinguish between an event in either 2014 and 2015, as evident by very large CVs ( $>1$ ) for those years (**Table 4.8**). This is also evident by the wide confidence intervals surrounding F in these years for the 2005, 2014 and 2015 red tide model (**Figure 4.63**). When red tide was considered in all three years, estimated recruitment deviations in both 2014 and 2015 revealed the largest changes between model runs. Red tide mortality was better estimated when included in either 2014 or 2015, with red tide mortality estimated at 0.257 ( $CV = 0.429$ ) in 2014 in the SEDAR61 Base Model and at 0.262 ( $CV = 0.459$ ) in the 2015 sensitivity run.



### Index Group Removals

In general, the removal of each group of indices had a relatively small impact on the estimates of SSB, recruitment, and F when considering the uncertainty (i.e., trends remain within confidence intervals) (**Figure 4.64**). These model outputs were nearly identical to the SEDAR61 Base Model when the commercial indices were removed. The removal of the recreational indices resulted in slightly lower estimated SSB between 2006 and 2014, smaller recruitment estimates between 2008 and 2014, and higher fishing mortality estimates in 2012 and 2013 (**Figure 4.64**). The removal of the fishery-independent indices resulted in relatively similar trends in SSB and recruits to the SEDAR61 Base Model, lower fishing mortality rates during 2005 and between 2012 and 2013, and higher fishing mortality rates from 2014 to 2016.

### Estimation of Steepness

Both sensitivity runs estimating steepness resulted in relatively similar values, with the no prior run estimating steepness at 0.735 ( $CV = 0.083$ ) and the run with an informative prior estimating steepness at 0.728 ( $CV = 0.079$ ) (**Table 4.7**). While trends in SSB were relatively consistent across the time series for each steepness sensitivity run, virgin SSB estimates were higher and more variable when steepness was estimated (**Figure 4.65**). Slightly higher recruits were estimated by the SEDAR61 Base Model in both the beginning and end of the time series (**Figure 4.65**). When steepness was estimated, annual fishing mortality rates were slightly higher between 1986 and 1992, but nearly identical during the remainder of the time series (**Figure 4.65**).

## 5. REFERENCE POINTS

Prior to SEDAR42, MSY-based reference points were used to determine stock status for Red Grouper (SEFSC 2002; SEDAR12 2006; SEDAR12 Update 2009). During the Review Process of the SEDAR42 AW Assessment Model, where steepness was estimated at 0.8 (with a symmetrical beta prior of 0.84 from Shertzer and Conn (2012)), the Review Panel concluded that the stock-recruitment relationship was uninformative and the estimate of steepness “was a bit low compared to other comparable fish stocks (around 0.9 would be more in line with other similar stocks).” The SEDAR42 Review Panel recommended fixing steepness at 0.99 and using SPR-based reference points using a target of 30% as the proxy for MSY.

$F_{SPR30\%}$  was chosen as the proxy for  $F_{MSY}$  during the SEDAR42 Review process and projections were undertaken using this value. The maximum fishing mortality threshold (MFMT) was assumed to be equal to the fishing mortality rate that produces a spawning potential ratio (SPR) of 30% in equilibrium. However, since SEDAR42, there has been a change in the minimum stock size threshold (MSST) value based on Amendment 44 to the Gulf of Mexico Reef Fish Fishery Management Plan (SERO 2017). Previously MSST was calculated as  $(1 - M) * SSB_{SPR30\%}$ , where  $M = 0.144$  (i.e., the average value of M from the Lorenzen M curve for fully selected ages). Amendment 44 now calculates MSST for Red Grouper as  $0.5 * SSB_{SPR30\%}$ . Therefore, stock status in 2017 is provided based on both values of MSST to provide continuity from the previous assessment.

### 5.1 Methods

Deterministic projections were run using the Stock Synthesis 3 model to evaluate stock status. Equilibrium projections were run from 2018 to 2117 using the same parameter values and population dynamics as the SEDAR61 Base Model where equilibrium was assumed to be obtained in the terminal year of projections (2117; see **Table 5.1** for a summary of projection settings). Because the SEDAR61 Base Model assumes a fixed steepness of essentially 1.0, the projections assumed that forecasted recruitment would continue at recent average levels (i.e., projected recruitment was near the ‘virgin’ recruitment level for the recent years, 2010 – 2017, of 17.4 million fish). For all years of the projections it was assumed that recent fishery dynamics would continue indefinitely including maintaining a 76% to 24% allocation of commercial to recreational catch. The selectivity for each fleet was taken from the terminal year of the assessment and relative harvest rates for the directed fisheries were assumed to stay in proportion to the terminal three year average (2015 – 2017) values. Similarly, discarding and retention practices were assumed to continue as they had in the three most recent years (2015 – 2017). Final landings estimates for 2018 were obtained for the commercial and recreational fleets (**Table 5.2**). Commercial landings for 2019 were based on the 2019 ACL of 3.16 million pounds as specified in the Emergency Rule effective May 17, 2019 (<https://www.fisheries.noaa.gov/action/emergency-rule-modify-gulf-mexico-red-grouper-annual-catch-limit>), under the assumption that the ACL would be removed in 2019. The allocation of catch by commercial fleet in 2019 was based on the ratio of commercial vertical line to longline landings (30%:70%) in 2017 (note 2018 ratio: 28%:72%). Recreational landings (in number of fish) for 2019 were assumed identical to 2018 landings.

For SPR-based analysis, the harvest rate (total biomass killed / total biomass) that led to a SPR of 30% (i.e.,  $SPR = \frac{\frac{SSB}{R}}{\frac{SSB_0}{R_0}} = 0.30$ , which is equivalent to  $\frac{SSB}{SSB_0}$  when steepness = 1.0 and recruitment is constant) was obtained by iteratively adjusting yield streams. The fishing mortality rates exerted by the directed fleets were scaled up or down by the same proportional amount until the fishing mortality that achieved a SPR of 30% in equilibrium was obtained in addition to retaining the catch fractions at the allocation fractions among fleets.

Stock status for Red Grouper in 2017 was determined based on comparison of the given year fishing mortality to the MFMT (i.e.,  $F_{SPR30\%}$ ) and the given year SSB compared to the MSST ( $0.5 * SSB_{SPR30\%}$ ). As mentioned, the previous approach for calculating MSST ( $[1 - M] * SSB_{SPR30\%}$ ) was also provided as a bridge to the results of the SEDAR42 assessment. Corresponding overfishing limits (OFLs) were calculated as the median (50<sup>th</sup> percentile) of the probability density function (PDF) of retained yield (millions of pounds) using the projection of  $F_{SPR30\%}$  (i.e., the yields that achieved the SPR target in equilibrium). Uncertainty in derived quantities (including retained yield) was carried through the projections from the parameter estimation phase in the stock assessment model and represented the approximate variance from the inversion of the Hessian matrix.

Per the terms of reference, additional projection runs included projecting landings fixed at the 2017 target, projecting optimal yield (i.e.,  $F_{OY} = 75\% * F_{SPR30\%}$ ) and  $F = 0$ . For the optimal yield run, the directed fishing mortality was decreased to 75% of the directed fishing mortality at

F<sub>SPR30%</sub>. For the F = 0 run all fishing mortality was eliminated including discards and the population was projected until equilibrium.

## 5.2 Treatment of 2018 Red Tide Event

Potential effects of the 2018 red tide were discussed in detail at the SEDAR61 DW/AW Workshop because this event has implications in terms of projections for Red Grouper. At the time of the SEDAR61 DW/AW Workshop (September 2018), qualitative impressions of a severe event in the making were provided by fishermen and other stakeholders in attendance. In response to concerns about the 2018 red tide raised by stakeholders, an initiative was put into place by SEFSC to systematically explore local ecological knowledge (LEK) regarding red tides with individual and small groups of fishermen using oral history and participatory mapping. Relevant information was extracted from each of the oral histories and was quantified to compare the recent 2017-2019 red tide to previous red tides in terms of severity, recovery time, temporal extent and species killed. Below we briefly review the results pertaining to the 2018 red tide event; additional details are provided in SEDAR61-WP20.

Of 42 oral history interviews conducted in communities located on the southwest Florida coast from Clearwater south to Everglades City, fishermen consistently identified three significant recent red tide event periods: 2005, 2013-2015, and 2017-2018. For the 2018 event, the vast majority of interviewees (>90%) described the event as “devastating” or “major” (**Figure 5.1; Table 5.3**). These results may be biased by the areas that have been covered in the LEK assessment to date (all South of Clearwater), as the 2014 event is known to have occurred north of the Clearwater area with particularly severe effects in the Middle Grounds. However, the overall severity designations for all bloom events do not differ based on the county of residence of the interviewee, and there do not appear to be regional trends in the rankings of severity across time (**Figure 5.2**).

Given the lack of quantitative data on the severity of the 2018 red tide event at the time of SEDAR61, but the suspected negative impact on the Red Grouper stock, we conducted projections across five potential levels of red tide mortality assuming the 2018 red tide event was:

1. Not severe (Red Tide Mortality = 0)
2. Half as severe as the 2014 red tide (Red Tide Mortality = 0.1285)
3. Similar in severity to the 2014 red tide (Red Tide Mortality = 0.257)
4. Similar in severity to the 2005 red tide (Red Tide Mortality = 0.339)
5. Twice as severe as the 2005 red tide (Red Tide Mortality = 0.678)

## 5.3 Stock Status

The harvest rate that results in a SPR of 30% in equilibrium was at 0.259, while the resulting SSB at 30% of SPR was 748,241 eggs with an MSST ( $0.5 * SSB_{SPR30\%}$ ) of 374,121 eggs (see **Table 5.4** for the relevant MSRA management reference points and benchmarks). The continuity value for MSST ( $[1 - M] * SSB_{SPR30\%}$ ) was equal to 640,494 eggs. All of the calculated MSRA benchmarks differ from the SEDAR42 Final Model. Virgin recruitment and unfished SSB were much lower in the SEDAR61 Base Model, which can be attributed to the issues with initial

conditions discussed previously (see **Section 3.3.3**). As a result, the SEDAR61 Base Model has a higher MFMT. The large differences in MSST benchmarks are due to the change in the fecundity vector for SEDAR61 (see **Section 2.2.5.3**).

The SEDAR61 Base Model indicates that the Gulf of Mexico Red Grouper stock, based on current definitions of MSST ( $0.5 * SSB_{SPR30\%}$ ) and MFMT, is not overfished and overfishing is not occurring ( $SSB_{2017} / MSST_{NEW} = 1.64$ ;  $F_{CURRENT} / MFMT = 0.784$ ; **Table 5.4**). An important caveat to this result is that under the previous definition of MSST ( $[1 - M] * SSB_{SPR30\%}$ ) the Red Grouper resource would be considered overfished in 2017 ( $SSB_{2017} / MSST_{OLD} = 0.96$ ). Based on the new definition for MSST ( $0.5 * SSB_{SPR30\%}$ ) the Red Grouper stock has not been overfished at any point in the time series. The stock was undergoing overfishing in the early portion of the time series (**Table 5.5**; **Figure 5.3**).

Projections aimed at achieving a SSB ratio of 30% in equilibrium suggest that the stock should increase until 2020 and then decline as Red Grouper from the relatively high 2013 recruitment event are fished out (**Figure 5.4**; see **Table 5.5** for a summary of projected stock status).

There are a number of important caveats for these projections. First, these calculations do not account for the highly variable nature of recruitment events nor the fundamental relation between adult spawners and subsequent recruits. Projections are completely deterministic and based on the assumption that future recruitment will remain constant at recent averages (i.e., steepness is approximately 1.0). Despite uncertainty about the nature of the spawner recruit relationship for Red Grouper, it should not be presumed that one does not exist. The assumptions utilized may not be adequate for short-term projections given concerns over the 2018 red tide event (see **Sections 5.4-5.5**). In addition, long-term equilibrium conditions are unlikely to hold for any resource and should only be utilized for general comparative purposes.

## 5.4 Overfishing Limits

The OFL is based on the median catches from the projections that achieve a SPR ratio of 30% in equilibrium. Catches based on the overfishing limit are expected to start at relatively high levels (8.53 million pounds) in 2020 before leveling off in 2038 (around 7.74 million pounds; **Table 5.6**). Near-term OFLs are substantially lower than predicted by the SEDAR42 Final Model projections (14.16 million pounds based on the average between 2016 and 2020), for reasons discussed in **Section 3.3.3**. However, OFLs predicted by the SEDAR61 Base Model are more in line with those predicted by the previous Red Grouper assessment (8.1 million pounds). Once the 2013 recruitment event has been fished out and the projections begin to rely on constant average recruitment levels, associated OFLs begin to decrease and level out around 7.74 million pounds (**Figure 5.4**). As expected, the assumed level of red tide mortality in 2018 has a large impact on the OFL (**Figure 5.5**). In the worst-case scenario, assuming the 2018 red tide event was twice as severe as the 2005 event, depletion is predicted to drop below the MSST ( $0.5 * SSB_{SPR30\%}$ ) between 2019 until 2024. As a result, OFLs under this scenario would be reduced considerably. The remaining scenarios of 2018 red tide severity do not show the same concerning drops below MSST, but do show reductions in OFLs commensurate with severity (i.e., larger reductions with more severe events).

The probability of overfishing was estimated in 2020 through 2024 for the Gulf of Mexico Red Grouper SEDAR61 Base Model by comparing the probability density functions (PDF) of the retained yield (millions of pounds; averaged between 2020-2024) between projection scenarios. The probability of overfishing was determined by summing up the area under each PDF curve of retained yield (millions of pounds) for each red tide scenario that exceeded the catch level for achieving an SPR of 30% in equilibrium, Optimum Yield, or maintaining 2017 catch levels. In the event of a low to highly severe red tide in 2018, the probability of overfishing is predicted to exceed 50% when the catch level is the median of the PDF for the projection that achieves an SPR ratio of 30% in equilibrium (**Table 5.7; Figure 5.6**).

### 5.5 Other Projection Runs

Trends in projected yields of the  $F_{OY}$  projections were not substantially different from the OFL projections. Initial catches were relatively lower than the SPR30% projection, leading to slightly higher SPR overall (**Figure 5.4**). Similar trends were noted across 2018 red tide scenarios, with the worst-case scenario resulting in predicted depletion below MSST ( $0.5 * SSB_{SPR30\%}$ ) starting in 2019 and lasting until 2023 as well as large reductions in projected yields (**Figure 5.7**). The other 2018 red tide scenarios do not predict large drops in yield starting in 2020. When compared to a catch level corresponding to  $F$  at Optimum Yield, the probability of overfishing is predicted to exceed 50% in the event of a moderate (e.g., 2014) to severe red tide in 2018 (**Table 5.7; Figure 5.6**).

The remaining scenarios,  $F = 0$  and landings fixed at 2017 levels, led to considerable reductions in yield compared to the other scenarios while building SPR to levels above 0.6 in the longer term (**Figure 5.4**). From 2017 landings levels, inclusion of 2018 red tide mortality would result in predicted depletion below MSST ( $0.5 * SSB_{SPR30\%}$ ) in the worst-case scenario from 2019 through 2025 (**Figure 5.8**). Smaller reductions in depletion are predicted for less severe red tide in 2018. When compared to a catch level corresponding to 2017 landings, the probability of overfishing is predicted to remain well below 50% in all 2018 red tide scenarios except the most severe scenario (**Table 5.7; Figure 5.6**).

## 6. DISCUSSION

Overall, the SEDAR61 Base Model appears to perform fairly well and improves upon some major deficiencies in data inputs and model settings from the SEDAR42 Final Model used to provide management advice (SEDAR42 2015; GMFMC SSC 2016). Significant changes were made to data inputs using new recommended methodologies for calculating: recreational data inputs using revised MRIP data (landings, discards, CPUE and age composition); observed discards for the commercial vertical line and longline fisheries after identifying the most appropriate metrics for fishing effort; an index of relative abundance and associated length composition for the Combined Video Survey using a habitat-based methodology to combine the three video surveys; and age and size composition sample sizes inputted as the square root of observed sample sizes rather than arbitrary caps. Additional data collection led to updates for data inputs including von Bertalanffy growth parameters, natural mortality, and the fecundity-at-age vector. New data inputs included an index of relative abundance and size composition from the FWRI Hook and Line Repetitive Time Drop Survey, which covers key Red Grouper habitat

and provides important information on size composition in recent years. All remaining data inputs, with the exception of the commercial CPUE indices for the vertical line and longline, were updated to reflect the new terminal year of 2017.

In addition to changes in data inputs, substantial changes were made to the assessment model configuration. The most significant change was the correction of initial conditions from the SEDAR42 Final Model, which had a large impact on model outcomes. Initial equilibrium catches are approximated from the average landings of Red Grouper in the first five years of the time series. Unfortunately, the number of requested changes to the SEDAR42 AW Model during the three-day Review Workshop (e.g., change in start year, consolidation of recreational fleets into a single fleet along with reprocessing of all necessary data inputs, etc.) precluded adequate error checking in model inputs and evaluation of model diagnostics. This time constraint contributed to an error in calculating the initial equilibrium catches in the SEDAR42 Final Model and caused the allowable catch advice to double, as was noted at the SEDAR42 Review Workshop. The evolution of the SEDAR process towards “Research Track” assessments, which will allow more time for model building and thorough evaluation by the Assessment Development Team (stock assessment analyst plus additional stock assessment experts), should greatly reduce the chances of presenting assessment models before performance and diagnostics are adequately evaluated.

Other major changes to the assessment model to help reduce overparametrization and improve model stability included: starting the model in 1986 to take advantage of the longest period of highly reliable landings; reconfiguring the red tide pseudo-fishing fleet to operate solely in years with severe events; using size-based selectivity for the fishing fleets rather than age-based selectivity, revising parameterization of retention, and implementing the Francis method for iterative reweighting of composition data.

These changes to data inputs and model configuration greatly improved fits to data inputs, most notably commercial discards and discard length compositions for the commercial longline and recreational fleets, which were key areas of poor fits discussed during the SEDAR42 Review Workshop. Model performance also improved considerably over the SEDAR42 Final Model, with less pronounced residual patterns for many data inputs, fewer moderate to high correlations between parameters, and fewer parameters with *CVs* exceeding 1. Model diagnostics were also much improved, particularly in the jitter analysis where the SEDAR42 Final Model revealed considerable model instability. Re-evaluating parametrizations of selectivity and retention in the SEDAR61 Base Model helped reduce the overparametrization of the SEDAR42 Final Model, which was initially configured to mimic the ASAP model in the SEDAR12 Update (SEDAR12 Update 2009). No major patterns were evident in the retrospective patterning, and both bootstrap and jack-knife analyses generally demonstrated that the model was able to obtain a similar solution for all runs. However, there were some minor issues with initial fishing mortality rates in the bootstrap analysis, with the parameter estimates from the SEDAR61 Base Model and bootstraps suggesting different values for the initial *F*s. Future assessments of Red Grouper should focus on refining approaches to calculate historical landings to unfished conditions. While considerable uncertainty exists and has been discussed in past assessments, annual estimates of uncertainty can accompany landings in Stock Synthesis version 3.3 (Methot et al. 2018). Using the full time series, while accurately reflecting uncertainties in removals, would

help alleviate the concerns over approximating initial conditions in both the SEDAR42 and current assessments.

A key uncertainty for the Gulf of Mexico Red Grouper stock assessment and most assessment models in general, is the stock-recruitment relationship. The SEDAR61 Base Model maintains the assumption of a steepness value of 0.99, which was recommended by the SEDAR42 Review Panel to allow projections assuming recent average recruitment. This Review Panel recommendation was based on an uninformative stock recruitment relationship, in addition to general consensus that the “estimated steepness of 0.8 was low compared to other comparable fish stocks (around 0.9 would be more in line with other similar stocks)” (SEDAR42 2015). Past Red Grouper assessments have used steepness values as low as 0.68 in the Gulf of Mexico, with estimates generally above 0.8 (**Table 6.1**). The constant recruitment approach for projections is not necessarily ideal because it eliminates the dependency of recruitment on spawners, which implies that recruitment never falters even at extremely low stock sizes (i.e., recruitment overfishing is not possible). The constant recruitment assumption is appropriate for short-term projections where SSB is not likely to decrease rapidly, which may be an issue for Red Grouper and other stocks that experience large declines due to red tides. In addition, the current configuration for projections can lead to inappropriate long-term or equilibrium projections. Therefore, the current projections must be interpreted very carefully due to the strong assumptions that were made, and should not be used for equilibrium calculations (i.e., catch limits should be updated regularly to account for changes in recruitment dynamics).

Stock assessments of protogynous stocks typically model reproductive potential in the form of combined male and female SSB (Shepherd et al. 2013). South Atlantic assessments of Red Grouper have followed this general approach. Brooks et al. (2008) explored via simulation, the various SSB approaches and stock assessment performance given uncertainties regarding loss of males and reduced fertility and concluded that SSB-combined is best when the potential for decreased fertility is moderate or unknown. While the percentage of males is relatively high for Red Grouper (range: 14-30%; SEDAR61-WP-04, -08) compared to other groupers (e.g., Gag Grouper, 3%; SEDAR33 2014), this decision should be revisited in Red Grouper future assessments. The SEDAR42 Review Panel recommended future research to explore how both protogyny and harem breeding would affect stock status and reproductive potential under conditions of (i) low population density, and (ii) disproportionate sex ratios. Such an analysis would be informative in assisting the assessment of such population properties as recovery times and would assist managers to understand changing uncertainties at low stock densities or unusual sex ratios for hermaphroditic stocks such as Red Grouper.

Another major source of uncertainty for the Gulf of Mexico Red Grouper stock assessment is how past red tides have impacted various age-classes and how future red tides will impact the population. While mortality due to past red tides has been accounted for in 2005 and 2014, major uncertainties remain regarding the response of Red Grouper (and other species) to these events (i.e., Do they move? Effect on age structure?). Presently, the red tides are assumed to affect all age classes including age-0s, with high mortality for age-0s supported by the ecosystem analysis provided in SEDAR61-WP06 for the 2005 event. Collections of fish during red tide events would allow for the size/age selectivity of mortality to be determined, and might also allow for some minimum estimates of total mortality, although obtaining samples is difficult due to human

hazards and rapid decomposition (Driggers et al. 2016). Additional research refining current ecosystem models could allow an ecosystem-level evaluation of how red tides affect the movement and population dynamics of Red Grouper, their prey base, and other species. In addition, an exploration of Vessel Monitoring System data could address whether fishing effort is shifting to unaffected regions during red tide events, and therefore potentially affecting catchability.

A major critique of the SEDAR42 assessment was the inclusion of too many indices of relative abundance which often showed conflicting trends or high variability. Following the recommendation of the SEDAR42 Review Panel, future Red Grouper assessments should take a more critical approach to the selection of abundance indices and set a higher quality threshold for inclusion. Including indices not actually indexing abundance or of poor quality could downgrade the model fit to some or all of the other datasets, including other genuine indices of abundance. The sensitivity run with the commercial CPUE indices removed demonstrated that these indices may no longer be necessary for the Red Grouper model, because their removal had very limited effect on model performance or estimated population trends. The removal of the recreational CPUE indices tended to result in some slight differences in SSB and recruitment, but had very little impact on recent trends. There are always concerns whether fishery CPUE can accurately reflect population trends (Maunder et al. 2006), but these issues can be enhanced when complex regulatory regimes exist that may impact or alter fishing dynamics (as is the case in the Gulf of Mexico; see **Figure 4.3**).

Overall, the SEDAR61 Base Model appears to demonstrate better model performance and diagnostics compared to the SEDAR42 Final Model. The Gulf of Mexico Red Grouper resource is not undergoing overfishing or being overfished based on the revised definition of MSST ( $0.5 * SSB_{SPR30\%}$ ). However, concerns over the severity of the 2018 red tide event are warranted as this event has a strong influence on projected stock dynamics for Red Grouper.

## 6.1 Research Recommendations

### Age and Growth

- Investigate methods to better collect age structure samples randomly and systematically from all fishing sectors, especially the recreational sector which is highly under represented
- Explore growth model alternatives that includes both the non-random sampling due to minimum size restrictions (Diaz et al. 2004) and non-random sampling due to biases in over/under sampling specific length bins (Chih 2014a, 2014b).
- Continue collaboration with ageing facilities throughout the Gulf of Mexico and South Atlantic. These efforts will include the annual reading of reference sets for Red Grouper and other reef fish, and annual meetings to review the interpretation of ageing structures and the timing of annual band deposition.
- Continue ongoing research evaluating the potential for aging errors (edge type definitions, quality control, seasonal trends, etc.) of Red Grouper (among other reef fish) discussed in SEDAR61-DW17 and SEDAR62-DW18 (posted for SEDAR62) to determine if and how age assignment problems could affect the estimation of both age frequency distributions and growth curves and whether alternative methods (e.g., using second season ALKs or length based assessment models) may be needed to address these potential issues.



- Explore the use of Fourier Transform Near-Infrared Spectroscopy (FT-NIRS) to derive ages for Red Grouper and other reef fish.
- Ensure robust communication between age reading laboratories and stock assessment scientists to assure a mutual understanding of the age advancement protocols for age readers and the age advancement protocols used in the assessment models. Concerns raised could be further explored during subsequent SEDAR assessments for those species.

**Discard Mortality**

- Continue data collection from observer programs

**Maturity/Sexual Transition**

- Explore changes in reproductive parameters over time and space (e.g., Moe [1969] vs now)
- Explore choice of criteria to assign maturity

**Fecundity**

- Explore appropriate measures of reproductive potential such as combined male/female SSB which has been more commonly applied for protogynous fishes (Shepherd et al. 2013)

**Landings**

- Re-evaluate historical landings in light of the new MRIP estimates of catch and effort and revise as necessary
- Assign annual uncertainty estimates (e.g., SE) to historic and recent commercial and recreational landings by fishery, which would allow the assessment to include all available landings data while accounting for greater uncertainty in the historic period

**Discards**

- Obtain consistent funding source to ensure continuation of sampling of discard length composition for Red Grouper and other species

**Commercial CPUE indices**

- Additional research is needed to better understand the influence of the IFQ program on fisher behavior and investigate alternative analyses

**Recreational CPUE indices**

- Additional research is needed to investigate if assumptions are appropriate across full time series (e.g., targeting, trip length, effects of various regulations, red snapper)

**Surveys**

- Use of fishery-independent data, such as from the Combined Video Survey, to explore the spatial overlap of red tide with Red Grouper (and other reef fishes)

**MRIP size data**

- Conduct a simulation study to evaluate whether different imputation processes (e.g., different imputation methods, algorithms, validity of assumptions, etc.) actually produce benefits that outweigh the uncertainties of adding imputed data to the observed data

- Determine the feasibility of developing weighting factors for data sources other than MRIP or how to determine effective sample sizes when combining various data sources

### **Composition data**

- Consider using the number of stations or trips from which the compositions came as input sample sizes for composition data, rather than the number of fish to more appropriately weight the composition data relative to other data inputs
- Convert all composition data to conditional age-at-length to avoid a mixing of length compositions and age compositions being fit to. Using conditional age-at-length contains more detailed information about the relationship between size and age and provides a stronger ability to estimate growth parameters, especially the variance of size-at-age

### **Red Tide**

- Enable rapid response sampling following severe events to quantify numbers, sizes and species composition of fish in fish kills
- Continue red tide index modeling efforts, specifically by ironing out issues with products derived from MODIS (e.g., de-band)
- Cooperative research with fishermen to track red tide blooms offshore and provide information on species composition, numbers and sizes in fish kills
- Evaluate impacts of red tides on food web dynamics and investigate recovery lags when forage base is impacted
- Conduct tagging studies to investigate response of Red Grouper and other species to red tide events, including fish movement and avoidance
- Use Vessel Monitoring System data to test hypotheses provided by stakeholders that vessels are shifting their distribution in response to fish moving during red tides
- Simulation test the various approaches for incorporating red tide mortality into the assessment model to determine the trade-offs associated with each approach

### **Projections**

- Evaluate current approach used for setting up and conducting projections and consider conducting a meta-analysis of steepness to assist in set-up of projections

## **7. ACKNOWLEDGEMENTS**

The SEDAR61 assessment would not have been possible without the efforts of the numerous SEFSC, SERO, and GMFMC staff along with the many academic and research partners involved throughout the Gulf of Mexico. In particular, those who helped compile the documents and input datasets including: Julie Neer (SEDAR Coordinator); Ryan Rindone (Management History); Emily Muehlstein (summary of results from GMFMC online voluntary data collection tool); Refik Orhun and Beth Wrege (Commercial Catch); Vivian Matter and Kelly Fitzpatrick (Recreational Catch and Discards); Allison Shideler, Steve Smith, and Kevin McCarthy (Commercial Discards); Brett Pierce (Commercial Discard Length Frequency); Jeff Pulver (Commercial Discard Mortality); Adyan Rios (Recreational CPUE, Red Tide Interviews); Gary Fitzhugh, Linda Lombardi-Carlson, and Susan Lowerre-Barbieri (Life History); Chris Gardner, Kate Overly, Adam Pollack, David Hanisko, Walter Ingram Jr., Kevin Thompson, Theodore

Switzer, Mary Christman, Sean Keenan, Matt Campbell, Heather Christiansen, Brent Winner (Fishery Independent Indices); Dave Chagaris, Dylan Sinnickson, John Walter III (Red Tide Indices); , Mandy Karnauskas, Matt McPherson, Michael Jepson, Amanda Stoltz, and Suzana Blake (Red Tide Interviews); Ching-Ping Chih (Size and Age Data); Dominique Lazarre, Beverly Sauls (Recreational Discard Length Frequency). Additional thanks are extended to Rick Methot and Nathan Vaughan for assistance with projections and modeling issues with SS3.3.

## 8. REFERENCES

- Brooks, E.N., K.W. Shertzer, T. Gedamke, and D.S. Vaughan. 2008. Stock assessment of protogynous fish: evaluating measures of spawning biomass used to estimate biological reference points. *Fishery Bulletin* 106:12-28.
- Chih, C-P. 2014a. Length and age frequency distributions for red groupers collected in the Gulf of Mexico from 1984 to 2013. SEDAR42-DW-18. SEDAR, North Charleston, SC. 42 pp.
- Chih, C-P. 2014b. Variations in length frequency distributions and age length keys for red groupers collected in the Gulf of Mexico. SEDAR42-DW-12. SEDAR, North Charleston, SC. 26 pp.
- Diaz, G.A., C.E. Porch, and M. Ortiz. 2004. Growth models for red snapper in U.S. Gulf of Mexico waters estimated from landings with minimum size limit restrictions. NMFS/SEFSC/SFD 2004-038, 13 p.
- Driggers, W.B., M.D. Campbell, A.J. Debose, K.M. Hannan, M.D. Hendon, T.L. Martin and C.C. Nichols. 2016. Environmental conditions and catch rates of predatory fishes associated with a mass mortality on the West Florida Shelf. *Estuarine Coastal and Shelf Science* 168:40-49.
- Francis, R.I.C.C. 2011. Data weighting in statistical fisheries stock assessment models. *Canadian Journal of Fisheries and Aquatic Sciences*. 68:1124-1138.
- GMFMC SSC (Gulf of Mexico Fishery Management Council Scientific and Statistical Committee). 2016. Stock Assessment Review Summary: SEDAR42 – Gulf Red Grouper. 5 pp. Available at: <http://sedarweb.org/report-gulf-mexico-ssc-review-sedar-42-red-grouper-assessment>.
- Hulson, P.-J., D. Hanselman, and T. Quinn. 2012. Determining effective sample size in integrated age-structured assessment models. *ICES Journal of Marine Science*, 69:281-292.
- Karnauskas, M. M. McPherson, S. Sagarese, A. Rios, M. Jepson, A. Stoltz and S. Blake. 2019. Timeline of severe red tide events on the West Florida Shelf: insights from oral histories. SEDAR61-WP20, SEDAR, North Charleston, SC. 16 pp.
- Lorenzen, K. 2005. Population dynamics and potential of fisheries stock enhancement: practical theory for assessment and policy analysis. *Philosophical Transactions of the Royal*

Society of London. Biological Sciences. 360:171-189.

Maunder, M.N., and A.E. Punt. 2013. A review of integrated analysis in fisheries stock assessment. *Fisheries Research* 142:61-74.

Maunder, M.N., J.R. Sibert, A. Fonteneau, J. Hampton, P. Kleiber and S.J. Harley. 2006. Interpreting catch per unit effort data to assess the status of individual stocks and communities. *ICES Journal of Marine Science* 63(8):1373-1385.

Methot, R.D. and I.G. Taylor. 2011. Adjusting for bias due to variability of estimated recruitments in fishery assessment models. *Canadian Journal of Fisheries and Aquatic Sciences*, 68(10):1744-1760.

Methot, R.D., C.R. Wetzel and I.G. Taylor. 2018. Stock Synthesis User Manual Version 3.30.12. NOAA Fisheries, Seattle, WA. 235 pp.

Methot, R.D., and C.R. Wetzel. 2013. Stock synthesis: a biological and statistical framework for fish stock assessment and fishery management. *Fisheries Research* 142:86–99.

Moe, M. A., Jr. 1969. Biology of the red grouper *Epinephelus morio* (Valenciennes) from the eastern Gulf of Mexico. Florida Department of Natural Resources Marine Resources Laboratory Professional Paper No. 10, 95 p.

RFSAP (Gulf of Mexico Fishery Management Council's Reef Fish Stock Assessment Panel). 2000. December 2000 report of the Reef Fish Stock Assessment Panel. Gulf of Mexico Fishery Management Council. 3018 U.S. Highway 301 North, Suite 1000. Tampa, FL 33619. 22 pp.

Rose, K.A., J.H. Cowan, K.O. Winemiller, R.A. Myers, and R. Hilborn. 2001. Compensatory density dependence in fish populations: importance, controversy, understanding and prognosis. *Fish and Fisheries* 2(4):293-327.

Schirripa, M. J., C. M. Legault, and M. Ortiz. 1999. The red grouper fishery of the Gulf of Mexico: assessment 3.0. Southeast Fisheries Science Center, Miami, FL. Sustainable Fisheries Division Contribution SFD 98/99-56. 57 pp.

SEFSC (Southeast Fisheries Science Center). 2002. Draft status of red grouper in United States waters of the Gulf of Mexico during 1986 - 2001. Southeast Fisheries Science Center, Miami, FL. Sustainable Fisheries Division contribution SFD 01/02-175rev.

SEDAR (Southeast Data Assessment and Review). 2006. SEDAR12: Gulf of Mexico Red Grouper Stock Assessment Report. SEDAR, North Charleston, SC. 358 p. Available at: <http://sedarweb.org/sedar-12>.

SEDAR (Southeast Data Assessment and Review). 2009. SEDAR12 Update: Gulf of Mexico Red Grouper Stock Assessment Report. SEDAR, North Charleston, SC. 143 p. Available at: <http://sedarweb.org/sedar-12>.

SEDAR (Southeast Data Assessment and Review). 2010. SEDAR19: South Atlantic Red Grouper Stock Assessment Report. SEDAR, North Charleston, SC. 612 p. Available at: <http://sedarweb.org/sedar-19>.

SEDAR (Southeast Data Assessment and Review). 2014. SEDAR33: Gulf of Mexico Gag Grouper Stock Assessment Report. SEDAR, North Charleston, SC. 609 p. Available at: <http://sedarweb.org/sedar-33>.

SEDAR (Southeast Data Assessment and Review). 2015. SEDAR42: Gulf of Mexico Red Grouper Stock Assessment Report. SEDAR, North Charleston, SC. 612 p. Available at: <http://sedarweb.org/sedar-42>.

SEDAR (Southeast Data Assessment and Review). 2017. SEDAR53: South Atlantic Red Grouper Stock Assessment Report. SEDAR, North Charleston, SC. 159 p. Available at: <http://sedarweb.org/sedar-53>.

Shepherd, G., K. Shertzer, J. Coakley and M. Caldwell (Eds.). 2013. Modeling protogynous hermaphrodite fishes workshop. SEDAR33-RD-19. SEDAR, North Charleston, SC. 35 pp.

Shertzer, K.W. and P.B. Conn. 2012. Spawner-recruit relationships of demersal marine fishes: prior distribution of steepness. *Bulletin of Marine Science*, 88(1):39-50.

Walter, J., M.C. Christman, J.H. Landsberg, B. Linton., K. Steidinger, R. Stumpf, and J. Tustison. 2013. Satellite derived indices of red tide severity for input for Gulf of Mexico Gag grouper stock assessment. SEDAR33-DW08, SEDAR, North Charleston, SC. 43 p.

## 9. TABLES

**Table 4.1.** List of Stock Synthesis parameters for Gulf of Mexico Red Grouper. The list includes predicted parameter values and their associated standard deviations, lower and upper bounds of the parameters, the prior densities assigned to the parameters as applicable, and phases (negative identifies parameters that were fixed). Parameters designated as fixed were held at their initial values and have no associated range or *SD*.

Label	Value	Range	<i>SD</i>	<i>CV</i>	Prior	Phase
L_at_Amin_Fem_GP_1	5.016	(1, 40)	0.685	0.137		3
L_at_Amax_Fem_GP_1	79.995					-3
VonBert_K_Fem_GP_1	0.121	(0.05, 0.3)	0.002	0.017		3
CV_young_Fem_GP_1	0.142					-3
CV_old_Fem_GP_1	0.164					-3
Wtlen_1_Fem_GP_1	5.99E-06					-3
Wtlen_2_Fem_GP_1	3.25					-3
Mat50%_Fem_GP_1	2.8					-3
Mat_slope_Fem_GP_1	-1.15					-3
Eggs_scalar_Fem_GP_1	4.47E-08					-3
Eggs_exp_len_Fem_GP_1	5.48					-3
CohortGrowDev	1					-1
FracFemale_GP_1	1					-99
SR_LN(R0)	9.925	(1, 40)	0.035	0.004		1
SR_BH_steep	0.99					-1
SR_sigmaR	0.815	(0, 2)	0.111	0.136		5
SR_regime	0					-1
SR_autocorr	0					-99
Early_InitAge_6	0					
Early_InitAge_5	0					
Early_InitAge_4	0					
Early_InitAge_3	0					
Early_InitAge_2	0					
Early_InitAge_1	0					
Early_RecrDev_1986	0					
Early_RecrDev_1987	0					
Early_RecrDev_1988	0					
Early_RecrDev_1989	0					
Early_RecrDev_1990	0					
Early_RecrDev_1991	0					
Early_RecrDev_1992	0					
Main_RecrDev_1993	0.315	(-5, 5)	0.195	0.619		4
Main_RecrDev_1994	-0.444	(-5, 5)	0.401	0.903		4
Main_RecrDev_1995	0.937	(-5, 5)	0.147	0.157		4
Main_RecrDev_1996	-0.592	(-5, 5)	0.361	0.610		4
Main_RecrDev_1997	-1.087	(-5, 5)	0.483	0.444		4
Main_RecrDev_1998	1.674	(-5, 5)	0.118	0.070		4
Main_RecrDev_1999	-0.543	(-5, 5)	0.476	0.877		4
Main_RecrDev_2000	-0.686	(-5, 5)	0.488	0.711		4
Main_RecrDev_2001	1.175	(-5, 5)	0.170	0.145		4
Main_RecrDev_2002	-0.84	(-5, 5)	0.519	0.618		4
Main_RecrDev_2003	0.202	(-5, 5)	0.245	1.213		4
Main_RecrDev_2004	-0.97	(-5, 5)	0.519	0.535		4
Main_RecrDev_2005	2.047	(-5, 5)	0.138	0.067		4

**Table 4.1. Continued** List of Stock Synthesis parameters for Gulf of Mexico Red Grouper.

Label	Value	Range	SD	CV	Prior	Phase
Main_RecrDev_2006	0.734	(-5, 5)	0.185	0.252		4
Main_RecrDev_2007	-0.934	(-5, 5)	0.480	0.514		4
Main_RecrDev_2008	-0.271	(-5, 5)	0.266	0.982		4
Main_RecrDev_2009	0.071	(-5, 5)	0.216	3.042		4
Main_RecrDev_2010	-0.610	(-5, 5)	0.333	0.546		4
Main_RecrDev_2011	-0.135	(-5, 5)	0.260	1.926		4
Main_RecrDev_2012	-0.147	(-5, 5)	0.324	2.204		4
Main_RecrDev_2013	1.092	(-5, 5)	0.223	0.204		4
Main_RecrDev_2014	0.252	(-5, 5)	0.422	1.675		4
Main_RecrDev_2015	-0.410	(-5, 5)	0.569	1.388		4
Main_RecrDev_2016	-0.476	(-5, 5)	0.725	1.523		4
Main_RecrDev_2017	-0.354	(-5, 5)	0.779	2.201		4
InitF_seas_1flt_1commHL	0.129	(0, 1)	0.024	0.186		1
InitF_seas_1flt_2commLL	0.090	(0, 1)	0.018	0.200		1
InitF_seas_1flt_3commTrap	0.019	(0, 1)	0.004	0.211		1
InitF_seas_1flt_4Rec	0.245	(0, 1)	0.050	0.204		1
F_fleet_1_YR_1986_s_1	0.163	(0, 8)	0.018	0.110		1
F_fleet_1_YR_1987_s_1	0.140	(0, 8)	0.026	0.186		1
F_fleet_1_YR_1988_s_1	0.114	(0, 8)	0.021	0.184		1
F_fleet_1_YR_1989_s_1	0.242	(0, 8)	0.042	0.174		1
F_fleet_1_YR_1990_s_1	0.265	(0, 8)	0.048	0.181		1
F_fleet_1_YR_1991_s_1	0.226	(0, 8)	0.041	0.181		1
F_fleet_1_YR_1992_s_1	0.154	(0, 8)	0.028	0.182		1
F_fleet_1_YR_1993_s_1	0.107	(0, 8)	0.017	0.159		1
F_fleet_1_YR_1994_s_1	0.107	(0, 8)	0.017	0.159		1
F_fleet_1_YR_1995_s_1	0.083	(0, 8)	0.014	0.169		1
F_fleet_1_YR_1996_s_1	0.076	(0, 8)	0.012	0.158		1
F_fleet_1_YR_1997_s_1	0.077	(0, 8)	0.012	0.156		1
F_fleet_1_YR_1998_s_1	0.057	(0, 8)	0.009	0.158		1
F_fleet_1_YR_1999_s_1	0.082	(0, 8)	0.013	0.159		1
F_fleet_1_YR_2000_s_1	0.110	(0, 8)	0.017	0.155		1
F_fleet_1_YR_2001_s_1	0.103	(0, 8)	0.016	0.155		1
F_fleet_1_YR_2002_s_1	0.104	(0, 8)	0.017	0.163		1
F_fleet_1_YR_2003_s_1	0.073	(0, 8)	0.012	0.164		1
F_fleet_1_YR_2004_s_1	0.075	(0, 8)	0.013	0.173		1
F_fleet_1_YR_2005_s_1	0.078	(0, 8)	0.013	0.167		1
F_fleet_1_YR_2006_s_1	0.091	(0, 8)	0.014	0.154		1
F_fleet_1_YR_2007_s_1	0.099	(0, 8)	0.016	0.162		1
F_fleet_1_YR_2008_s_1	0.109	(0, 8)	0.017	0.156		1
F_fleet_1_YR_2009_s_1	0.151	(0, 8)	0.024	0.159		1
F_fleet_1_YR_2010_s_1	0.081	(0, 8)	0.013	0.160		1
F_fleet_1_YR_2011_s_1	0.085	(0, 8)	0.014	0.165		1
F_fleet_1_YR_2012_s_1	0.086	(0, 8)	0.014	0.163		1
F_fleet_1_YR_2013_s_1	0.059	(0, 8)	0.010	0.169		1
F_fleet_1_YR_2014_s_1	0.082	(0, 8)	0.013	0.159		1
F_fleet_1_YR_2015_s_1	0.127	(0, 8)	0.021	0.165		1
F_fleet_1_YR_2016_s_1	0.113	(0, 8)	0.020	0.177		1
F_fleet_1_YR_2017_s_1	0.095	(0, 8)	0.018	0.189		1
F_fleet_2_YR_1986_s_1	0.093	(0, 8)	0.012	0.129		1
F_fleet_2_YR_1987_s_1	0.148	(0, 8)	0.028	0.189		1
F_fleet_2_YR_1988_s_1	0.087	(0, 8)	0.016	0.184		1

F\_fleet\_2\_YR\_1989\_s\_1      0.140      (0, 8)      0.025      0.179      1

**Table 4.1. Continued** List of Stock Synthesis parameters for Gulf of Mexico Red Grouper.

Label	Value	Range	SD	CV	Prior	Phase
F_fleet_2_YR_1990_s_1	0.157	(0, 8)	0.030	0.191		1
F_fleet_2_YR_1991_s_1	0.208	(0, 8)	0.038	0.183		1
F_fleet_2_YR_1992_s_1	0.196	(0, 8)	0.035	0.179		1
F_fleet_2_YR_1993_s_1	0.312	(0, 8)	0.049	0.157		1
F_fleet_2_YR_1994_s_1	0.240	(0, 8)	0.038	0.158		1
F_fleet_2_YR_1995_s_1	0.178	(0, 8)	0.029	0.163		1
F_fleet_2_YR_1996_s_1	0.235	(0, 8)	0.037	0.157		1
F_fleet_2_YR_1997_s_1	0.226	(0, 8)	0.035	0.155		1
F_fleet_2_YR_1998_s_1	0.173	(0, 8)	0.026	0.150		1
F_fleet_2_YR_1999_s_1	0.217	(0, 8)	0.032	0.147		1
F_fleet_2_YR_2000_s_1	0.172	(0, 8)	0.026	0.151		1
F_fleet_2_YR_2001_s_1	0.192	(0, 8)	0.029	0.151		1
F_fleet_2_YR_2002_s_1	0.170	(0, 8)	0.027	0.159		1
F_fleet_2_YR_2003_s_1	0.153	(0, 8)	0.025	0.163		1
F_fleet_2_YR_2004_s_1	0.152	(0, 8)	0.026	0.171		1
F_fleet_2_YR_2005_s_1	0.149	(0, 8)	0.025	0.168		1
F_fleet_2_YR_2006_s_1	0.171	(0, 8)	0.027	0.158		1
F_fleet_2_YR_2007_s_1	0.112	(0, 8)	0.018	0.161		1
F_fleet_2_YR_2008_s_1	0.148	(0, 8)	0.023	0.155		1
F_fleet_2_YR_2009_s_1	0.053	(0, 8)	0.009	0.170		1
F_fleet_2_YR_2010_s_1	0.052	(0, 8)	0.009	0.173		1
F_fleet_2_YR_2011_s_1	0.098	(0, 8)	0.016	0.163		1
F_fleet_2_YR_2012_s_1	0.093	(0, 8)	0.015	0.161		1
F_fleet_2_YR_2013_s_1	0.086	(0, 8)	0.015	0.174		1
F_fleet_2_YR_2014_s_1	0.139	(0, 8)	0.023	0.165		1
F_fleet_2_YR_2015_s_1	0.144	(0, 8)	0.024	0.167		1
F_fleet_2_YR_2016_s_1	0.191	(0, 8)	0.034	0.178		1
F_fleet_2_YR_2017_s_1	0.149	(0, 8)	0.029	0.195		1
F_fleet_3_YR_1986_s_1	0.028	(0, 8)	0.004	0.143		1
F_fleet_3_YR_1987_s_1	0.019	(0, 8)	0.004	0.211		1
F_fleet_3_YR_1988_s_1	0.023	(0, 8)	0.005	0.217		1
F_fleet_3_YR_1989_s_1	0.028	(0, 8)	0.006	0.214		1
F_fleet_3_YR_1990_s_1	0.029	(0, 8)	0.006	0.207		1
F_fleet_3_YR_1991_s_1	0.036	(0, 8)	0.007	0.194		1
F_fleet_3_YR_1992_s_1	0.047	(0, 8)	0.009	0.191		1
F_fleet_3_YR_1993_s_1	0.063	(0, 8)	0.011	0.175		1
F_fleet_3_YR_1994_s_1	0.056	(0, 8)	0.010	0.179		1
F_fleet_3_YR_1995_s_1	0.075	(0, 8)	0.013	0.173		1
F_fleet_3_YR_1996_s_1	0.064	(0, 8)	0.011	0.172		1
F_fleet_3_YR_1997_s_1	0.066	(0, 8)	0.011	0.167		1
F_fleet_3_YR_1998_s_1	0.018	(0, 8)	0.003	0.167		1
F_fleet_3_YR_1999_s_1	0.041	(0, 8)	0.007	0.171		1
F_fleet_3_YR_2000_s_1	0.064	(0, 8)	0.011	0.172		1
F_fleet_3_YR_2001_s_1	0.046	(0, 8)	0.008	0.174		1
F_fleet_3_YR_2002_s_1	0.052	(0, 8)	0.010	0.192		1
F_fleet_3_YR_2003_s_1	0.037	(0, 8)	0.007	0.189		1
F_fleet_3_YR_2004_s_1	0.031	(0, 8)	0.006	0.194		1
F_fleet_3_YR_2005_s_1	0.031	(0, 8)	0.006	0.194		1
F_fleet_3_YR_2006_s_1	0.036	(0, 8)	0.006	0.167		1
F_fleet_3_YR_2007_s_1	0.001	(0, 8)	0			1
F_fleet_3_YR_2011_s_1	3.9E-07	(0, 8)	0			1



F\_fleet\_4\_YR\_1986\_s\_1                    0.488                    (0, 8)                    0.049                    0.100                    1  
**Table 4.1. Continued** List of Stock Synthesis parameters for Gulf of Mexico Red Grouper.

Label	Value	Range	SD	CV	Prior	Phase
F_fleet_4_YR_1987_s_1	0.173	(0, 8)	0.042	0.243		1
F_fleet_4_YR_1988_s_1	0.385	(0, 8)	0.088	0.229		1
F_fleet_4_YR_1989_s_1	0.863	(0, 8)	0.168	0.195		1
F_fleet_4_YR_1990_s_1	0.586	(0, 8)	0.128	0.218		1
F_fleet_4_YR_1991_s_1	0.648	(0, 8)	0.139	0.215		1
F_fleet_4_YR_1992_s_1	0.766	(0, 8)	0.165	0.215		1
F_fleet_4_YR_1993_s_1	0.558	(0, 8)	0.129	0.231		1
F_fleet_4_YR_1994_s_1	0.559	(0, 8)	0.131	0.234		1
F_fleet_4_YR_1995_s_1	0.638	(0, 8)	0.149	0.234		1
F_fleet_4_YR_1996_s_1	0.172	(0, 8)	0.040	0.233		1
F_fleet_4_YR_1997_s_1	0.220	(0, 8)	0.051	0.232		1
F_fleet_4_YR_1998_s_1	0.299	(0, 8)	0.068	0.227		1
F_fleet_4_YR_1999_s_1	0.579	(0, 8)	0.129	0.223		1
F_fleet_4_YR_2000_s_1	0.558	(0, 8)	0.124	0.222		1
F_fleet_4_YR_2001_s_1	0.359	(0, 8)	0.083	0.231		1
F_fleet_4_YR_2002_s_1	0.378	(0, 8)	0.089	0.235		1
F_fleet_4_YR_2003_s_1	0.307	(0, 8)	0.071	0.231		1
F_fleet_4_YR_2004_s_1	0.669	(0, 8)	0.158	0.236		1
F_fleet_4_YR_2005_s_1	0.325	(0, 8)	0.077	0.237		1
F_fleet_4_YR_2006_s_1	0.332	(0, 8)	0.075	0.226		1
F_fleet_4_YR_2007_s_1	0.254	(0, 8)	0.058	0.228		1
F_fleet_4_YR_2008_s_1	0.427	(0, 8)	0.095	0.222		1
F_fleet_4_YR_2009_s_1	0.346	(0, 8)	0.079	0.228		1
F_fleet_4_YR_2010_s_1	0.339	(0, 8)	0.077	0.227		1
F_fleet_4_YR_2011_s_1	0.292	(0, 8)	0.066	0.226		1
F_fleet_4_YR_2012_s_1	0.417	(0, 8)	0.096	0.230		1
F_fleet_4_YR_2013_s_1	0.622	(0, 8)	0.150	0.241		1
F_fleet_4_YR_2014_s_1	0.840	(0, 8)	0.199	0.237		1
F_fleet_4_YR_2015_s_1	0.723	(0, 8)	0.172	0.238		1
F_fleet_4_YR_2016_s_1	0.587	(0, 8)	0.149	0.254		1
F_fleet_4_YR_2017_s_1	0.410	(0, 8)	0.105	0.256		1
F_fleet_5_YR_2005_s_1	0.339	(0, 8)	0.105	0.310		1
F_fleet_5_YR_2014_s_1	0.257	(0, 8)	0.110	0.428		1
LnQ_base_commHL(1)	-8.763					-1
LnQ_base_commLL(2)	-8.976					-1
LnQ_base_Rec(4)	-7.132					-1
LnQ_base_SEAMAP_Vid(6)	-8.749					-1
LnQ_base_SEAMAP_GF(7)	-9.869					-1
LnQ_base_NMFS_BLL(8)	-8.644					-1
LnQ_base_CBT_PRSurv(9)	-9.234					-1
LnQ_base_FWRI_RTD(10)	-8.756					-1
Size_DblN_peak_commHL(1)	55.415	(10, 85)	0.346	0.006		2
Size_DblN_top_logit_commHL(1)	-12.059	(-15, 15)	1.999	0.166	Normal (-12.059, 2)	3
Size_DblN_ascend_se_commHL(1)	5					-3
Size_DblN_descend_se_commHL(1)	5					-3
Size_DblN_start_logit_commHL(1)	-999					-2
Size_DblN_end_logit_commHL(1)	-999					-4
Retain_L_infl_commHL(1)	0					-3
Retain_L_width_commHL(1)	0.25					-3
Retain_L_asymptote_logit_commHL(1)	10					-3

Retain\_L\_maleoffset\_commHL(1) 0 -4

**Table 4.1. Continued** List of Stock Synthesis parameters for Gulf of Mexico Red Grouper.

Label	Value	Range	SD	CV	Prior	Phase
DiscMort_L_infl_commHL(1)	-15					-2
DiscMort_L_width_commHL(1)	1					-4
DiscMort_L_level_old_commHL(1)	0.19					-2
DiscMort_L_male_offset_commHL(1)	0					-4
Size_DblN_peak_commLL(2)	52.461	(10, 85)	0.467	0.009		2
Size_DblN_top_logit_commLL(2)	-0.459	(-15, 15)	0.155	0.338	Normal (-0.349, 0.15)	3
Size_DblN_ascend_se_commLL(2)	5					-3
Size_DblN_descend_se_commLL(2)	5					-3
Size_DblN_start_logit_commLL(2)	-999					-2
Size_DblN_end_logit_commLL(2)	-999					-4
Retain_L_infl_commLL(2)	0					-3
Retain_L_width_commLL(2)	0.25					-3
Retain_L_asymptote_logit_commLL(2)	10					-3
Retain_L_maleoffset_commLL(2)	0					-4
DiscMort_L_infl_commLL(2)	-15					-2
DiscMort_L_width_commLL(2)	1					-4
DiscMort_L_level_old_commLL(2)	0.415					-2
DiscMort_L_male_offset_commLL(2)	0					-4
Size_DblN_peak_commTrap(3)	51.925	(10, 85)	0.882	0.017		2
Size_DblN_top_logit_commTrap(3)	-1.213	(-15, 15)	0.821	0.677	Normal (-0.9, 1)	3
Size_DblN_ascend_se_commTrap(3)	5					-3
Size_DblN_descend_se_commTrap(3)	5					-3
Size_DblN_start_logit_commTrap(3)	-999					-2
Size_DblN_end_logit_commTrap(3)	-999					-4
Retain_L_infl_commTrap(3)	0					-3
Retain_L_width_commTrap(3)	0.25					-3
Retain_L_asymptote_logit_commTrap(3)	10					-3
Retain_L_maleoffset_commTrap(3)	0					-4
DiscMort_L_infl_commTrap(3)	-15					-2
DiscMort_L_width_commTrap(3)	1					-4
DiscMort_L_level_old_commTrap(3)	0.1					-2
DiscMort_L_male_offset_commTrap(3)	0					-4
Size_DblN_peak_Rec(4)	41.268	(10, 85)	1.445	0.035	Normal (41.349, 2)	2
Size_DblN_top_logit_Rec(4)	-2.05	(-15, 15)	0.328	0.160	Normal (-1.836, 0.56)	3
Size_DblN_ascend_se_Rec(4)	5.01	(-15, 15)	0.173	0.035	Normal (5, 0.35)	3
Size_DblN_descend_se_Rec(4)	2.864	(-15, 15)	0.616	0.215	Normal (3, 0.89)	3
Size_DblN_start_logit_Rec(4)	-999					-2
Size_DblN_end_logit_Rec(4)	-999					-4
Retain_L_infl_Rec(4)	43.969					-3
Retain_L_width_Rec(4)	0.5					-3
Retain_L_asymptote_logit_Rec(4)	10					-3
Retain_L_maleoffset_Rec(4)	0					-4
DiscMort_L_infl_Rec(4)	-15					-2
DiscMort_L_width_Rec(4)	1					-4
DiscMort_L_level_old_Rec(4)	0.116					-2
DiscMort_L_male_offset_Rec(4)	0					-4
Size_inflection_SEAMAP_Vid(6)	43.075	(0, 85)	2.193	0.051	Normal (42.537, 3)	2
Size_95%width_SEAMAP_Vid(6)	18.676	(0, 20)	2.105	0.113		2
Size_DblN_peak_SEAMAP_GF(7)	24.971	(10, 30)	1.773	0.071	Normal (24.732, 2.56)	2
Size_DblN_top_logit_SEAMAP_GF(7)	-5.204	(-15, 15)	1.819	0.350	Normal (-5, 2)	3
Size_DblN_ascend_se_SEAMAP_GF(7)	4.571	(-15, 15)	0.276	0.060	Normal (5, 1)	3

Size\_DblN\_descend\_se\_SEAMAP\_GF(7) 7.026 (-15, 15) 0.307 0.044 Normal (6.986, 0.42) 3

**Table 4.1. Continued** List of Stock Synthesis parameters for Gulf of Mexico Red Grouper.

Label	Value	Range	SD	CV	Prior	Phase
Size_DblN_start_logit_SEAMAP_GF(7)	-999			0.009		-2
Size_DblN_end_logit_SEAMAP_GF(7)	-999					-2
Size_inflection_NMFS_BLL(8)	42.625	(20, 129)	0.753	0.018	Normal (42.044, 1.04)	2
Size_95%width_NMFS_BLL(8)	10.895	(0, 50)	0.867	0.080		2
Size_inflection_FWRI_RTD(10)	34.198	(20, 60)	1.029	0.030	Normal (33.853, 1.4)	2
Size_95%width_FWRI_RTD(10)	10.751	(0, 50)	1.406	0.131		2
minage@sel=1_RedTide(5)	0.1					-3
maxage@sel=1_RedTide(5)	21					-3
Retain_L_infl_commHL(1)_BLK2repl_1990	48.975					-3
Retain_L_infl_commHL(1)_BLK2repl_2009	43.969					-3
Retain_L_width_commHL(1)_BLK2repl_1990	1.157					-3
Retain_L_width_commHL(1)_BLK2repl_2009	1.355	(0, 20)	0.102	0.075		3
Retain_L_asymptote_logit_commHL(1) _BLK2repl_1990	10					-3
Retain_L_asymptote_logit_commHL(1) _BLK2repl_2009	10					-3
Retain_L_infl_commLL(2)_BLK2repl_1990	48.975					-3
Retain_L_infl_commLL(2)_BLK2repl_2009	43.969					-3
Retain_L_width_commLL(2)_BLK2repl_1990	0.742	(0, 20)	0.228	0.307		3
Retain_L_width_commLL(2)_BLK2repl_2009	1.941	(0, 20)	0.17	0.088		3
Retain_L_asymptote_logit_commLL(2) _BLK2repl_1990	10					-3
Retain_L_asymptote_logit_commLL(2) _BLK2repl_2009	10					-3
Retain_L_infl_commTrap(3)_BLK3repl_1990	48.975					-3
Retain_L_width_commTrap(3)_BLK3repl_1990	0.1					-3
Retain_L_asymptote_logit_commTrap(3) _BLK3repl_1990	10					-3
Retain_L_infl_Rec(4)_BLK1repl_1990	48.795					-3
Retain_L_width_Rec(4)_BLK1repl_1990	2.865					-3
Retain_L_asymptote_logit_Rec(4) _BLK1repl_1990	1.29	(-10, 10)	0.416	0.322		3

**Table 4.2.** Predicted biomass (metric tons), spawning stock biomass (SSB, relative number of eggs), abundance (1000s of fish), age-0 recruits (1000s of fish), and depletion (SSB/SSB<sub>0</sub>) for Gulf of Mexico Red Grouper from the SEDAR61 Base Model run.

Year	Biomass	SSB	Abundance	Recruits	SSB/SSB <sub>0</sub>
1984	85,562	2,494,130	75,880	0	1.000
1985	20,189	910,754	62,149	0	0.365
1986	20,189	910,754	62,059	20,354	0.365
1987	18,683	835,964	61,178	20,341	0.335
1988	18,629	837,880	61,320	20,342	0.336
1989	18,409	827,801	61,177	20,340	0.332
1990	15,208	672,617	59,406	20,304	0.270
1991	15,223	683,550	59,807	20,307	0.274
1992	15,077	686,942	59,912	20,308	0.275
1993	15,017	691,605	60,752	21,157	0.277
1994	14,921	695,003	50,059	9,907	0.279
1995	15,251	716,270	73,704	39,448	0.287
1996	15,554	737,900	55,722	8,545	0.296
1997	16,673	793,522	43,914	5,215	0.318
1998	17,617	839,235	113,850	82,510	0.336
1999	18,724	901,870	79,545	8,988	0.362
2000	18,626	874,888	61,882	7,794	0.351
2001	19,302	885,506	93,699	50,111	0.355
2002	20,690	963,264	67,636	6,686	0.386
2003	22,224	1,046,640	66,471	18,963	0.420
2004	24,250	1,155,830	51,973	5,878	0.463
2005	24,220	1,163,400	156,242	120,013	0.466
2006	17,549	848,362	100,172	32,230	0.340
2007	17,846	832,783	71,871	6,076	0.334
2008	19,990	897,208	63,062	11,801	0.360
2009	21,829	982,062	61,463	16,629	0.394
2010	24,360	1,129,040	51,602	8,420	0.453
2011	26,932	1,279,980	50,618	13,549	0.513
2012	27,873	1,342,310	48,560	13,397	0.538
2013	26,911	1,291,330	79,119	46,221	0.518
2014	24,799	1,165,080	70,062	20,312	0.467
2015	16,619	745,182	46,898	11,439	0.299
2016	15,092	647,213	43,408	11,718	0.259
2017	14,446	613,517	43,823	14,234	0.246

**Table 4.3.** Estimates of annual exploitation rate (total biomass killed / total biomass) combined across all fleets for Gulf of Mexico Red Grouper, which was used as the proxy for annual fishing mortality rate. For 2005 and 2014, the value in parantheses reflects the total mortality that is the sum of all fishing mortality plus red tide mortality.

Year	SEDAR61	SEDAR42
1986	0.262	-
1987	0.207	-
1988	0.214	-
1989	0.379	-
1990	0.244	-
1991	0.268	-
1992	0.268	-
1993	0.280	0.287
1994	0.253	0.221
1995	0.241	0.227
1996	0.196	0.191
1997	0.205	0.174
1998	0.169	0.130
1999	0.250	0.177
2000	0.237	0.159
2001	0.203	0.133
2002	0.191	0.152
2003	0.157	0.120
2004	0.227	0.142
2005	0.158 (0.453)	0.555
2006	0.205	0.158
2007	0.146	0.108
2008	0.178	0.117
2009	0.128	0.089
2010	0.104	0.070
2011	0.145	0.094
2012	0.182	0.114
2013	0.191	0.129
2014	0.216 (0.429)	-
2015	0.231	-
2016	0.218	-
2017	0.160	-

**Table 4.4.** Annual apical estimates of fishing mortality, overall and by fleet for Gulf of Mexico Red Grouper. Note that red tide mortality was only estimated in years with severe red tide events (2005 and 2014).

Year	Overall	Commercial Vertical Line	Commercial Longline	Commercial Trap	Recreational	Red Tide
1986	0.26	0.16	0.09	0.03	0.49	-
1987	0.21	0.14	0.15	0.02	0.17	-
1988	0.21	0.11	0.09	0.02	0.39	-
1989	0.38	0.24	0.14	0.03	0.86	-
1990	0.24	0.26	0.16	0.03	0.59	-
1991	0.27	0.23	0.21	0.04	0.65	-
1992	0.27	0.15	0.20	0.05	0.77	-
1993	0.28	0.11	0.31	0.06	0.56	-
1994	0.25	0.11	0.24	0.06	0.56	-
1995	0.24	0.08	0.18	0.08	0.64	-
1996	0.20	0.08	0.23	0.06	0.17	-
1997	0.20	0.08	0.23	0.07	0.22	-
1998	0.17	0.06	0.17	0.02	0.30	-
1999	0.25	0.08	0.22	0.04	0.58	-
2000	0.24	0.11	0.17	0.06	0.56	-
2001	0.20	0.10	0.19	0.05	0.36	-
2002	0.19	0.10	0.17	0.05	0.38	-
2003	0.16	0.07	0.15	0.04	0.31	-
2004	0.23	0.07	0.15	0.03	0.67	-
2005	0.45	0.08	0.15	0.03	0.33	0.34
2006	0.20	0.09	0.17	0.04	0.33	-
2007	0.15	0.10	0.11	0.00	0.25	-
2008	0.18	0.11	0.15	0.00	0.43	-
2009	0.13	0.15	0.05	0.00	0.35	-
2010	0.10	0.08	0.05	0.00	0.34	-
2011	0.15	0.09	0.10	0.00	0.29	-
2012	0.18	0.09	0.09	0.00	0.42	-
2013	0.19	0.06	0.09	0.00	0.62	-
2014	0.43	0.08	0.14	0.00	0.84	0.26
2015	0.23	0.13	0.14	0.00	0.72	-
2016	0.22	0.11	0.19	0.00	0.59	-
2017	0.16	0.09	0.15	0.00	0.41	-

**Table 4.5.** Summary of moderately correlated (correlation coefficient > 0.7) parameters for the Gulf of Mexico Red Grouper Base Model. No correlations exceeded 0.95.

Parameter 1	Parameter 2	Correlation
F_fleet_2_YR_1986_s_1	F_fleet_1_YR_1986_s_1	0.770
Main_RecrDev_2005	Main_RecrDev_2001	0.713
Size_95%width_SEAMAP_Vid(6)	Size_inflection_SEAMAP_Vid(6)	0.710
Size_DblN_ascend_se_Rec(4)	Size_DblN_peak_Rec(4)	0.805
Size_DblN_ascend_se_SEAMAP_GF(7)	Size_DblN_peak_SEAMAP_GF(7)	0.808
VonBert_K_Fem_GP_1	L_at_Amin_Fem_GP_1	-0.862

**Table 4.6.** Summary of key model building runs towards the SEDAR61 Base Model for Gulf of Mexico Red Grouper. Note that steps within each model progression are not shown due to the vast number of intermediate runs conducted.

Stage	Model	NLL	Gradient	Estimated Parameters (Bounded)	Corr > 0.7 (>0.95)	Parm CVs > 1	$\sigma_R$	$\ln(R_0)$	Virgin SSB	Virgin Recruitment (1000s)
-	SEDAR42 Final Model (post-Review Panel changes)	2257.93	0.0300	250 (7)	151 (140)	63	1.238	10.39	8,236,070	32,458
-	SEDAR42 AW Model (proposed to Review Panel)	2836.86	0.3000	331 (2)	722 (140)	70	0.965	9.67	4,017,750	15,834
1	SEDAR61 Continuity (SS version 3.24)	2561.46	0.0077	270 (5)	222 (216)	63	1.153	10.4	8,302,860	32,722
1	SEDAR61 Continuity (SS version 3.3)	2561.45	0.0006	270 (1)	222 (216)	64	1.154	10.4	8,306,510	32,736
1	SEDAR61 Initial Update <sup>1</sup>	2566.97	0.0006	270 (3)	219 (213)	65	0.787	9.955	5,341,230	21,050
2	Data Update <sup>2</sup>	2696.9	0.0072	270 (2)	219 (215)	66	0.78	9.923	2,489,270	20,403
2	New Data <sup>3</sup>	2767.61	0.0000	276 (2)	221 (217)	71	0.783	9.918	2,474,580	20,283
2	AW3 Progress to 1993 Base <sup>4</sup>	-25.475	0.0002	206 (1)	38 (3)	41	0.551	10.05	2,831,710	23,210
2	AW4 Progress to 1993 Base <sup>5</sup>	452.969	0.0001	179 (0)	23 (0)	21	0.693	9.882	2,387,130	19,566
3	AW4 Progress to 1986 Base <sup>5</sup>	499.687	0.0001	209 (2)	27 (1)	22	0.639	10.050	2,819,970	23,114
3	AW5 1986 Base <sup>6</sup>	537.486	0.0001	178 (0)	6 (0)	8	0.815	9.925	2,494,130	20,443

<sup>1</sup> = Corrected initial equilibrium catch to be average of first five years

<sup>2</sup> = Updated Combined Video Survey index of abundance and size composition, recreational age composition, growth and M, and fecundity vector

<sup>3</sup> = Included index of relative abundance and size composition from the FWRI Hook and Line Repetitive Time Drop Survey

<sup>4</sup> = Red tide fleet only operating in years with severe event (i.e., no zeros), attempted to estimate steepness, converted random walk-at-age selectivity to double normal, updated recruitment bias adjustment, used square root of sample sizes for age and length composition, implemented Francis iterative reweighting

<sup>5</sup> = Removed survey lambda, tuned selectivity and retention parameters, changed NMFS Bottom Longline size-selectivity to logistic (asymptotic), updated recruitment bias adjustment, Francis iterative reweighting

<sup>6</sup> = Revised estimation of early recruitment deviations and phases of estimation, removed regime block, fixed retention parameters where possible based on available information (e.g., size limits), converted age-based selectivity to length-based selectivity for fishing fleets, changed Combined Video & FWRI Hook and Line Repetitive Time Drop Survey size selectivity patterns to logistic (asymptotic), fine-tuned selectivity parameters (e.g., priors), updated recruitment bias adjustment, Francis iterative reweighting



**Table 4.7.** Summary of sensitivity runs conducted on the SEDAR61 Base Model for Gulf of Mexico Red Grouper.

Sensitivity Run	NLL	Estimated Parameters (Bounded)	Steepness	$\sigma_R$	$\ln(R_0)$	Virgin SSB	Virgin Recruitment (1000s)
SEDAR61 Base	537.486	178 (0)	0.99	0.815	9.925	2,494,130	20,443
<b>RED TIDE</b>							
Red Tide in 2005 only	539.966	177 (0)	0.99	0.895	9.907	2,448,130	20,066
Red Tides in 2005 and 2015	537.746	178 (0)	0.99	0.822	9.921	2,483,900	20,359
Red Tides in 2005, 2014 and 2015	537.354	179 (0)	0.99	0.813	9.925	2,494,330	20,445
<b>INDEX REMOVAL</b>							
No Commercial vertical line	550.97	178 (0)	0.99	0.826	9.931	2,509,330	20,568
No Commercial longline	555.645	178 (0)	0.99	0.811	9.926	2,495,780	20,457
No Recreational headboat	554.443	178 (0)	0.99	0.859	9.924	2,490,560	20,414
No Combined Video	556.174	178 (0)	0.99	0.805	9.926	2,494,570	20,447
No SEAMAP Summer Groundfish	545.695	178 (0)	0.99	0.812	9.925	2,494,130	20,443
No NMFS Bottom Longline	545.581	178 (0)	0.99	0.825	9.921	2,483,900	20,359
No Recreational charter/private	547.157	178 (0)	0.99	0.821	9.915	2,469,490	20,241
No FWRI Hook and Line Repetitive Time Drop	540.584	178 (0)	0.99	0.816	9.926	2,494,610	20,447
No Commercial indices	569.342	178 (0)	0.99	0.822	9.932	2,511,440	20,585
No Recreational indices	567.542	178 (0)	0.99	0.841	9.911	2,459,130	20,156
No fishery-dependent indices	597.888	178 (0)	0.99	0.888	9.923	2,487,710	20,390
No fishery-independent indices	576.454	178 (0)	0.99	0.809	9.921	2,484,310	20,363
<b>STEEPNESS</b>							
Estimate steepness, no prior	532.704	179 (0)	0.74	0.803	10.064	2,865,200	23,485
Estimate steepness with prior from Shertzer and Conn (2012) analysis	532.831	179 (0)	0.73	0.802	10.069	2,879,470	23,602

**Table 4.8.** Comparison of estimated red tide mortality (with *CV*) for sensitivity runs of the SEDAR61 Base Model for Gulf of Mexico Red Grouper. Scenarios considered include red tide mortality: in 2005 only, in 2005 and 2014 (the base model), in 2005 and 2015, and in 2005, 2014, and 2015.

Years with Red Tide	2005	2014	2015
2005 only	0.339 (0.320)	-	-
2005 and 2014	0.339 (0.309)	0.257 (0.429)	-
2005 and 2015	0.337 (0.313)	-	0.262 (0.459)
2005, 2014 and 2015	0.338 (0.310)	0.174 (1.126)	0.109 (1.939)

**Table 5.1.** Summary of projection settings and equations for Gulf of Mexico Red Grouper.

Derived quantity	Equation	Parameter values
Recruitment ( <i>R</i> )	$R_{Year} = \frac{4hR_0SSB_{Year}}{SSB_0(1-h) + SSB_{Year}(5h-1)}$	$h = 0.99,$ $R_0 = 20.4$ million fish
Growth Curve	$L(t) = L_{\infty} [1 - e^{-k(t-t_0)}]$	$L_{\infty} = 79.995\text{cm}, k = 0.131\text{yr}^{-1}, t_0 = -0.87,$ See <b>Figure 4.2</b>
Weight-Length Relationship	$Weight = aL^b$	$a = 5.99\text{e-}06, b = 3.25,$ See <b>Figure 4.2</b>
Fecundity-at-Age ( <i>Fec</i> )	Input	See <b>Figure 2.12</b>
Selectivity ( <i>S</i> )	Input	See <b>Figure 4.29</b>
Retention ( <i>Ret</i> )	Input	See <b>Figure 4.31-4.34</b>
Discard Mortality ( <i>DM</i> )	Input	See <b>Table 2.6</b>
Natural Mortality ( <i>M</i> )	Input	See <b>Table 2.4</b>
Directed Fishing Mortality ( <i>F<sub>Dir</sub></i> ) by Fleet	$F_{Dir, Age, Year}^{Fleet} = S_{Dir, Age}^{Fleet} F_{Dir, Mult, year}^{Fleet} Ret_{Dir, Age}^{Fleet}$	Directed Fleets are commercial VL, LL, Trap, and Recreational (Headboat, Private, and Charter)
Directed Discard Fishing Mortality ( <i>F<sub>Disc</sub></i> ) by Fleet	$F_{Disc, Age, Year}^{Fleet} = F_{Dir, Mult, year}^{Fleet} (1 - Ret_{Dir, Age}^{Fleet}) DM_{Dir}^{Fleet}$	Fishing mortality due to discards for a directed fleet
Total Directed Fishing Mortality ( <i>F<sub>Tot_Dir</sub></i> ) by Fleet	$F_{Tot\_Dir, Age, Year}^{Fleet} = F_{Dir, Age, Year}^{Fleet} + F_{Disc, Age, Year}^{Fleet}$	Total fishing mortality for a directed fleet
Discard Fishing Mortality ( <i>F<sub>RT</sub></i> ) by Red Tide	$F_{RT, Age, Year}^{Fleet} = S_{RT, Age}^{Fleet} F_{RT, Mult, year}^{Fleet}$	Discard Fleet is Red Tide
Total Fishing Mortality ( <i>F<sub>Tot</sub></i> )	$F_{Tot, Age, Year} = \sum_{Fleet} F_{Tot\_Dir, Age, Year}^{Fleet} + F_{RT, Age, Year}^{Fleet}$	Total Fishing Mortality Summed Across All Fleets
Total Mortality ( <i>Z</i> )	$Z_{Age, Year} = F_{Tot, Age, Year} + M_{Age}$	Total Mortality Summed Across All Fleets
Abundance-at-Age ( <i>N</i> )	$N_{Age+1, Year+1} = N_{Age, Year} e^{-Z_{Age, Year}}$	Total Abundance
Spawning Stock Biomass ( <i>SSB</i> )	$SSB_{Year} = \sum_{Age=0}^{20} (Fec_{Age} N_{Age, Year} e^{-Z_{Age, Year}})$	SSB a function of fecundity, numbers, and mortality
Retained Catch-at-Age ( <i>C</i> ) by Fleet	$C_{Dir, Age, Year}^{Fleet} = N_{Age, Year} (1 - e^{-Z_{Age, Year}}) \frac{F_{Dir, Age, Year}^{Fleet}}{Z_{Age, Year}}$	Retained Catch for a Directed Fleet
Retained Yield ( <i>Y</i> ) by Fleet	$Y_{Dir, Year}^{Fleet} = \sum_{Age=0}^{20} W_{Age}^{Fleet} C_{Dir, Age, Year}^{Fleet}$	See SS3 Manual (Methot et al. 2018) for a Complete Description of the Length Integrated Fleet-Specific Weight-at-Age ( <i>W</i> )
Spawning Potential Ratio ( <i>SPR</i> )	$SPR = \frac{\frac{SSB}{R}}{\frac{SSB_0}{R_0}}$	$SSB_0 = 2,494,130$ eggs (relative)

**Table 5.2.** Landings used in 2018 (final) and 2019 (assumed) for projections of stock status for Gulf of Mexico Red Grouper. Values in red are based on the assumptions discussed in the text.

Fleet	Landings	Landings (pounds)	ACL	Breakdown of landings using ratio
<b>2018</b>				
Commercial vertical line	296 (mt)	652,360	8,190,000	
Commercial longline	759 (mt)	1,673,305		
Recreational	210,613 (Number)	-		2,580,000
<b>2019</b>				
Commercial vertical line	430 (mt)		3,160,000	948,000
Commercial longline	1,003 (mt)			2,212,000
Recreational	210,613 (Number)		1,000,000	

**Table 5.3.** Descriptors included within the three-level scale categories for severity of red tide events used in Local Ecological Knowledge interviews with stakeholders conducted by the Southeast Fisheries Science Center from August 2018 through May 2019.

Category	Minor	Major	Devastating
Descriptors	3/10	bad	9.5/10
	fairly significant	extensive	10/10
	medium/minor	intense	devastating
	minor	major	
	minor - strong	miserable	
	normal	pretty bad	
	not bad	really bad	
	patchy	severe	
	significant	terrible	
	small	very bad	
small events	worst		

**Table 5.4.** Summary of MSRA benchmarks and reference points for the SEDAR61 Gulf of Mexico Red Grouper assessment. Stock status in 2017 is provided relative to both the current ( $0.5 \cdot SSB_{SPR30\%}$ ) and old ( $[1 - M] \cdot SSB_{SPR30\%}$ ) definitions of MSST. SSB is in relative number of eggs, whereas F is a harvest rate (total biomass killed / total biomass).

Criteria	Definition	SEDAR42	SEDAR61
Base M	Average M for Fully Selected Ages	0.144	0.144
Steepness	SR Parameter	0.99	0.99
Virgin Recruitment	SR Parameter (R0)	32,458	20,443
SSB Unfished		8,236,070	2,494,130
Generation Time	Fecundity-Weighted Mean Age	10.95	11.17
SPR Target		0.30	0.30
<b>Mortality rate criteria</b>			
F <sub>MSY</sub> or Proxy	F <sub>SPR30%</sub>	0.212	0.259
MFMT	F <sub>SPR30%</sub>	0.212	0.259
FOY	0.75 * Direct F at F <sub>SPR30%</sub>	0.159	0.194
F <sub>current (2017)</sub>	Average F over terminal 3 years	0.126	0.203
F <sub>current (2017)</sub> / MFMT		0.594	0.784
Overfishing Occurring in 2017			<b>No</b>
<b>Biomass criteria</b>			
SSB <sub>MSY</sub> or Proxy	SSB <sub>SPR30%</sub>	2,447,900	748,241
MSST <sub>OLD</sub>	$(1 - M) \cdot SSB_{SPR30\%}$	2,095,402	640,494
MSST <sub>NEW</sub> (Amendment 44)	$0.5 \cdot SSB_{SPR30\%}$	-	374,120
SSB <sub>0</sub>	Virgin SSB	8,236,070	2,494,130
SSB <sub>2017</sub>	Terminal Year SSB	2,905,630	613,517
SSB <sub>2017</sub> / SSB <sub>SPR30%</sub>		1.19	0.82
SSB <sub>2017</sub> / MSST <sub>OLD</sub>		1.39	0.96
Overfished by Old Criteria in 2017			<b>Yes</b>
SSB <sub>2017</sub> / MSST <sub>NEW</sub>		-	1.64
Overfished by New Criteria in 2017			<b>No</b>
SSB <sub>2017</sub> / SSB <sub>0</sub>		0.35	0.25

**Table 5.5.** Summary of annual stock status estimates for Gulf of Mexico Red Grouper ( $F_{MSY}$  proxy =  $F_{SPR30\%}$ ). SSB is in relative number of eggs whereas F is the harvest rate (total biomass killed / total biomass; note that values for 2005 and 2014 are solely for fishing effort [i.e., red tide mortality has been excluded]). Red text identifies years exceeding the thresholds.

Year	F	F/MFMT	SSB	SSB/SSB <sub>SPR30%</sub>	SSB/MSST <sub>OLD</sub>	SSB/MSST <sub>NEW</sub>	SSB/SSB <sub>0</sub>
1986	0.26	1.01	910,754	1.22	1.42	2.43	0.37
1987	0.21	0.80	835,964	1.12	1.31	2.23	0.34
1988	0.21	0.83	837,880	1.12	1.31	2.24	0.34
1989	0.38	1.46	827,801	1.11	1.29	2.21	0.33
1990	0.24	0.94	672,617	0.90	1.05	1.80	0.27
1991	0.27	1.04	683,550	0.91	1.07	1.83	0.27
1992	0.27	1.03	686,942	0.92	1.07	1.84	0.28
1993	0.28	1.08	691,605	0.92	1.08	1.85	0.28
1994	0.25	0.98	695,003	0.93	1.09	1.86	0.28
1995	0.24	0.93	716,270	0.96	1.12	1.91	0.29
1996	0.20	0.76	737,900	0.99	1.15	1.97	0.30
1997	0.20	0.79	793,522	1.06	1.24	2.12	0.32
1998	0.17	0.65	839,235	1.12	1.31	2.24	0.34
1999	0.25	0.96	901,870	1.21	1.41	2.41	0.36
2000	0.24	0.91	874,888	1.17	1.37	2.34	0.35
2001	0.20	0.78	885,506	1.18	1.38	2.37	0.36
2002	0.19	0.74	963,264	1.29	1.50	2.57	0.39
2003	0.16	0.61	1,046,640	1.40	1.63	2.80	0.42
2004	0.23	0.88	1,155,830	1.54	1.80	3.09	0.46
2005	0.16	0.61	1,163,400	1.55	1.82	3.11	0.47
2006	0.20	0.79	848,362	1.13	1.32	2.27	0.34
2007	0.15	0.57	832,783	1.11	1.30	2.23	0.33
2008	0.18	0.69	897,208	1.20	1.40	2.40	0.36
2009	0.13	0.49	982,062	1.31	1.53	2.62	0.39
2010	0.10	0.40	1,129,040	1.51	1.76	3.02	0.45
2011	0.15	0.56	1,279,980	1.71	2.00	3.42	0.51
2012	0.18	0.70	1,342,310	1.79	2.10	3.59	0.54
2013	0.19	0.74	1,291,330	1.73	2.02	3.45	0.52
2014	0.22	0.83	1,165,080	1.56	1.82	3.11	0.47
2015	0.23	0.89	745,182	1.00	1.16	1.99	0.30
2016	0.22	0.84	647,213	0.86	1.01	1.73	0.26
2017	0.16	0.62	613,517	0.82	0.96	1.64	0.25

**Table 5.6.** Results of projections that achieve an SPR of 30% in equilibrium for Gulf of Mexico Red Grouper. Recruitment is in thousands of age-0 fish, F is the harvest rate (total biomass killed / total biomass), SSB is in relative number of eggs, and OFL is the overfishing limit in millions of pounds. Reference points are provided in **Table 5.4**. SSB ratios are shown for both MSST<sub>OLD</sub> ( $[1 - M] * SSB_{SPR30\%}$ .) and MSST<sub>NEW</sub> ( $0.5 * SSB_{SPR30\%}$ ).

Year	Recruitment	F	F/MFMT	SSB	SSB / SSB <sub>SPR30%</sub>	SSB / MSST <sub>OLD</sub>	SSB / MSST <sub>NEW</sub>	SSB / SSB <sub>0</sub>	OFL
2018	20,297	0.123	0.48	648,869	0.87	1.01	1.73	0.26	3.31
2019	20,315	0.136	0.52	712,318	0.95	1.11	1.90	0.29	4.13
2020	20,326	0.259	1.00	761,786	1.02	1.19	2.04	0.31	8.53
2021	20,314	0.259	1.00	709,129	0.95	1.11	1.90	0.28	8.00
2022	20,302	0.259	1.00	665,209	0.89	1.04	1.78	0.27	7.42
2023	20,295	0.259	1.00	639,864	0.86	1.00	1.71	0.26	6.97
2024	20,293	0.259	1.00	636,403	0.85	0.99	1.70	0.26	6.81
2025	20,297	0.259	1.00	649,057	0.87	1.01	1.73	0.26	6.88
2026	20,303	0.259	1.00	668,601	0.89	1.04	1.79	0.27	7.02
2027	20,309	0.259	1.00	688,299	0.92	1.07	1.84	0.28	7.17
2028	20,313	0.259	1.00	705,305	0.94	1.10	1.89	0.28	7.31
2029	20,316	0.259	1.00	718,863	0.96	1.12	1.92	0.29	7.42
2030	20,319	0.259	1.00	729,090	0.97	1.14	1.95	0.29	7.51
2031	20,321	0.259	1.00	736,445	0.98	1.15	1.97	0.30	7.58
2032	20,322	0.259	1.00	741,516	0.99	1.16	1.98	0.30	7.64
2033	20,323	0.259	1.00	744,855	1.00	1.16	1.99	0.30	7.67
2034	20,323	0.259	1.00	746,964	1.00	1.17	2.00	0.30	7.70
2035	20,323	0.259	1.00	748,185	1.00	1.17	2.00	0.30	7.72
2036	20,323	0.259	1.00	748,815	1.00	1.17	2.00	0.30	7.73
2037	20,324	0.259	1.00	749,075	1.00	1.17	2.00	0.30	7.73
2038	20,324	0.259	1.00	749,119	1.00	1.17	2.00	0.30	7.74
2039	20,324	0.259	1.00	749,053	1.00	1.17	2.00	0.30	7.74
2040	20,323	0.259	1.00	748,936	1.00	1.17	2.00	0.30	7.74
2041	20,323	0.259	1.00	748,803	1.00	1.17	2.00	0.30	7.74
2042	20,323	0.259	1.00	748,676	1.00	1.17	2.00	0.30	7.74
2043	20,323	0.259	1.00	748,566	1.00	1.17	2.00	0.30	7.74
2044	20,323	0.259	1.00	748,475	1.00	1.17	2.00	0.30	7.74
2045	20,323	0.259	1.00	748,403	1.00	1.17	2.00	0.30	7.74
2046	20,323	0.259	1.00	748,349	1.00	1.17	2.00	0.30	7.74
2047	20,323	0.259	1.00	748,310	1.00	1.17	2.00	0.30	7.74
2048	20,323	0.259	1.00	748,283	1.00	1.17	2.00	0.30	7.74
2049	20,323	0.259	1.00	748,264	1.00	1.17	2.00	0.30	7.74
2050	20,323	0.259	1.00	748,252	1.00	1.17	2.00	0.30	7.74

**Table 5.6. Continued** Results of projections that achieve an SPR of 30% in equilibrium for Gulf of Mexico Red Grouper. “...” identifies years between 2065 and 2116 which show identical results.

Year	Recruit- ment	F	F/MFMT	SSB	SSB / SSB <sub>SPR30%</sub>	SSB / MSST <sub>OLD</sub>	SSB / MSST <sub>NEW</sub>	SSB / SSB <sub>0</sub>	OFL
2051	20,323	0.259	1.00	748,245	1.00	1.17	2.00	0.30	7.74
2052	20,323	0.259	1.00	748,240	1.00	1.17	2.00	0.30	7.74
2053	20,323	0.259	1.00	748,238	1.00	1.17	2.00	0.30	7.74
2054	20,323	0.259	1.00	748,237	1.00	1.17	2.00	0.30	7.74
2055	20,323	0.259	1.00	748,237	1.00	1.17	2.00	0.30	7.74
2056	20,323	0.259	1.00	748,238	1.00	1.17	2.00	0.30	7.74
2057	20,323	0.259	1.00	748,238	1.00	1.17	2.00	0.30	7.74
2058	20,323	0.259	1.00	748,239	1.00	1.17	2.00	0.30	7.74
2059	20,323	0.259	1.00	748,239	1.00	1.17	2.00	0.30	7.74
2060	20,323	0.259	1.00	748,240	1.00	1.17	2.00	0.30	7.74
2061	20,323	0.259	1.00	748,240	1.00	1.17	2.00	0.30	7.74
2062	20,323	0.259	1.00	748,240	1.00	1.17	2.00	0.30	7.74
2063	20,323	0.259	1.00	748,240	1.00	1.17	2.00	0.30	7.74
2064	20,323	0.259	1.00	748,241	1.00	1.17	2.00	0.30	7.74
...	...	...	...	...	...	...	...	...	...
2117	20,323	0.259	1.00	748,241	1.00	1.17	2.00	0.30	7.74



**Table 5.7.** Estimated probability of overfishing in 2020 through 2024 for the Gulf of Mexico Red Grouper SEDAR61 Base Model under projections that achieve an SPR of 30% in equilibrium, Optimum Yield, and maintain 2017 catch levels. The probability of overfishing was determined by summing up the area under each probability density function (PDF) curve of retained yield (millions of pounds) for each red tide scenario that exceeded the catch level for  $F_{SPR30\%}$ ,  $F_{OY}$  and 2017 landings (column 2; see **Figure 5.6**). The five 2018 red tide scenarios considered: (1) no red tide mortality in 2018; (2) half of 2014 (0.1285); (3) same as 2014 (0.257), (4) same as 2005 (0.339), and (5) double 2005 (0.678).

Scenario	2020-2024 Mean Catch (Pounds)	No 2018 Red Tide	Half 2014	2014	2005	Double 2005
Equilibrium yield at $F_{MSY}$ proxy ( $F_{SPR30\%}$ )	7,643,329	0.50	0.82	0.98	1.00	1.00
F at Optimum Yield ( $F_{OY} = 75\% F_{SPR30\%}$ )	6,423,319	0.15	0.40	0.74	0.90	1.00
Landings fixed at 2017 target	4,305,711	0.00	0.01	0.05	0.11	0.83

**Table 6.1.** Review of steepness parameterization and evaluation in past Red Grouper stock assessments.

Reference	Steepness		Notes
	Fixed	Estimated	
<b>Gulf of Mexico</b>			
SEDAR42 (2015)	0.99	0.802 (CV=0.16)	Estimated in the AW Model using a symmetrical beta prior (0.83, SD = 1) taken from the SEDAR update assessment and in line with Shertzer and Conn (2012). The model estimated a steepness of 0.99 when the prior was removed. Likelihood profile showed most likely solution near 0.8. Sensitivity runs were conducted for 0.65 and 0.98. Model with steepness fixed at 0.99 used for management
SEDAR 12 Update (2009)		0.84 (SD=0.05)	Steepness was estimated using a triangular prior (as recommended by the 2002 RFSAP [Reef Fish Stock Assessment Panel]) with a maximum probability at 0.7, and zero probability of steepness < 0.3 or >0.9.
SEDAR 12 (2006)		0.84	Steepness was estimated using a triangular prior (as recommended by the 2002 Reef Fish Stock Assessment Panel) with a maximum probability at 0.7, and zero probability of steepness < 0.3 or >0.9. The assessment panel reviewed this prior, and agreed with the 2002 RFSAP that steepness values greater than 0.9 are not likely to be realistic for Red Grouper. Steepness values of 0.7 and 0.8 were used to develop a range for management parameter estimates, with a caveat that the 0.8 value was well above both the estimated value (0.68) and expected values for species of similar life history. Sensitivity runs for 0.6 and 0.9.
SEFSC (2002)	0.7, 0.8		Insufficient contrast to allow steepness to be reliably estimated, although the model favored higher steepness. The RFSAP continues to believe that while there is uncertainty in the steepness values, a value of 0.7 is more realistic than 0.8. While a steepness value of 0.8 is not out of the question, it is on the high end of the range for species with life history characteristics similar to those of Red Grouper (Rose et al. 2001), and higher than the best fit to the limited spawner-recruit data (steepness = 0.68) currently available for this species (Schirripa et al. 1999). Moreover, because Red Grouper life history is made additionally complex by hermaphroditism, which has unknown consequences with respect to spawner-recruit relationships, some caution is recommended when biological benchmarks are hovering around threshold levels.
RFSAP (2000)	0.68		Additional analyses requested after 1999 assessment. A steepness of 0.7 was used in the short time series simulations to match the estimated steepness in the long time series. The steepness was estimated by the model to be 1.0, a highly unrealistic steepness value. Based on these analyses additional analyses and the ensuing discussion, NMFS repeated these runs using a fixed steepness of 0.68.
Schirripa et al. 1999	0.4, 0.5, 0.6, 0.7, 0.8		Preliminary analyses determined that the stock-recruitment relationship could not be well estimated for the short time series. As a result, steepness was fixed at five different levels (0.4, 0.5, 0.6, 0.7, and 0.8) based on work done for Pacific stocks (see report for details).
<b>South Atlantic</b>			
SEDAR 53 (2017)	0.87		Steepness was not estimable (hit the upper bound of 0.99), even when applying a prior distribution to inform the estimation (Shertzer and Conn 2012). Likelihood profiles suggest steepness is likely greater than 0.75, but the profile was relatively flat between 0.75 and 0.99. For the base run, the Panel fixed steepness at the midpoint steepness = 0.87 of that range. Sensitivity runs at 0.75 and 0.99.
SEDAR 19 (2010)		0.92	Steepness was estimated in the AW Model using a normal prior (0.72; SEDAR19-DW06). Review Panel agreed steepness could be estimated, but suggested model calculated values were high, implying that recruitment can be high at low stock sizes. The two-way trip in biomass provided information to estimate steepness. Likelihood profiles suggest steepness between 0.76 and 0.97

10. FIGURES

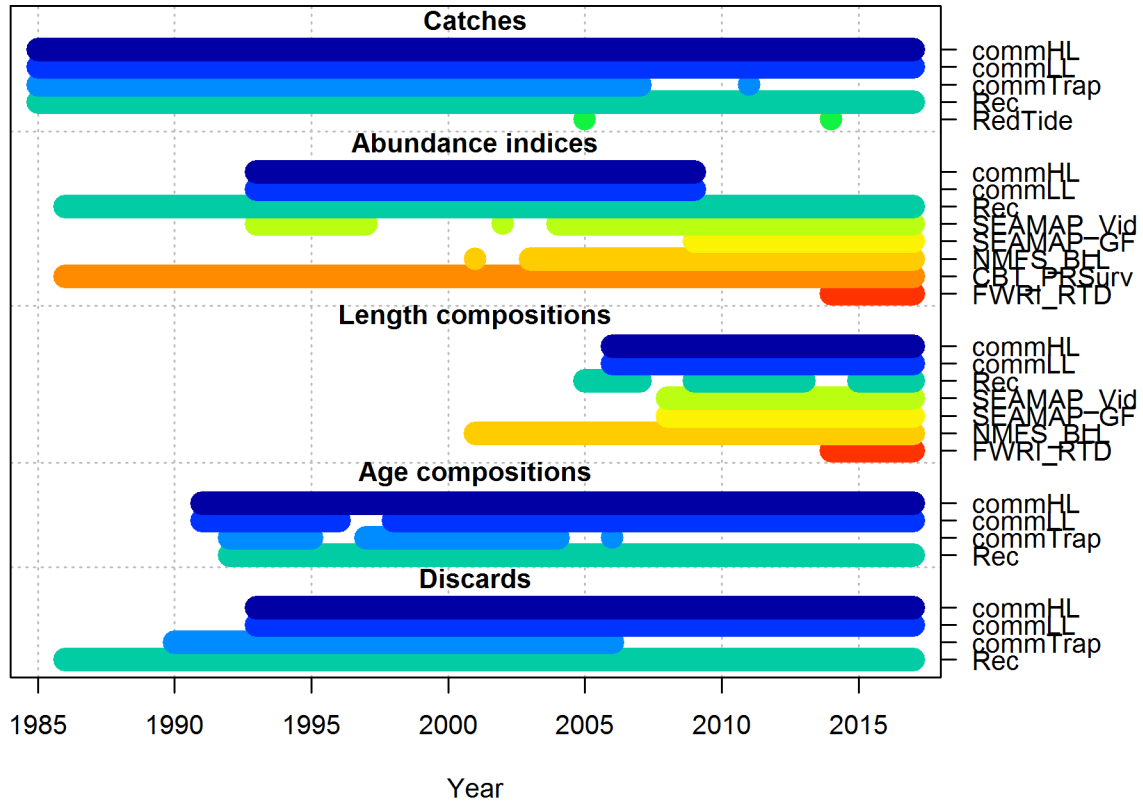
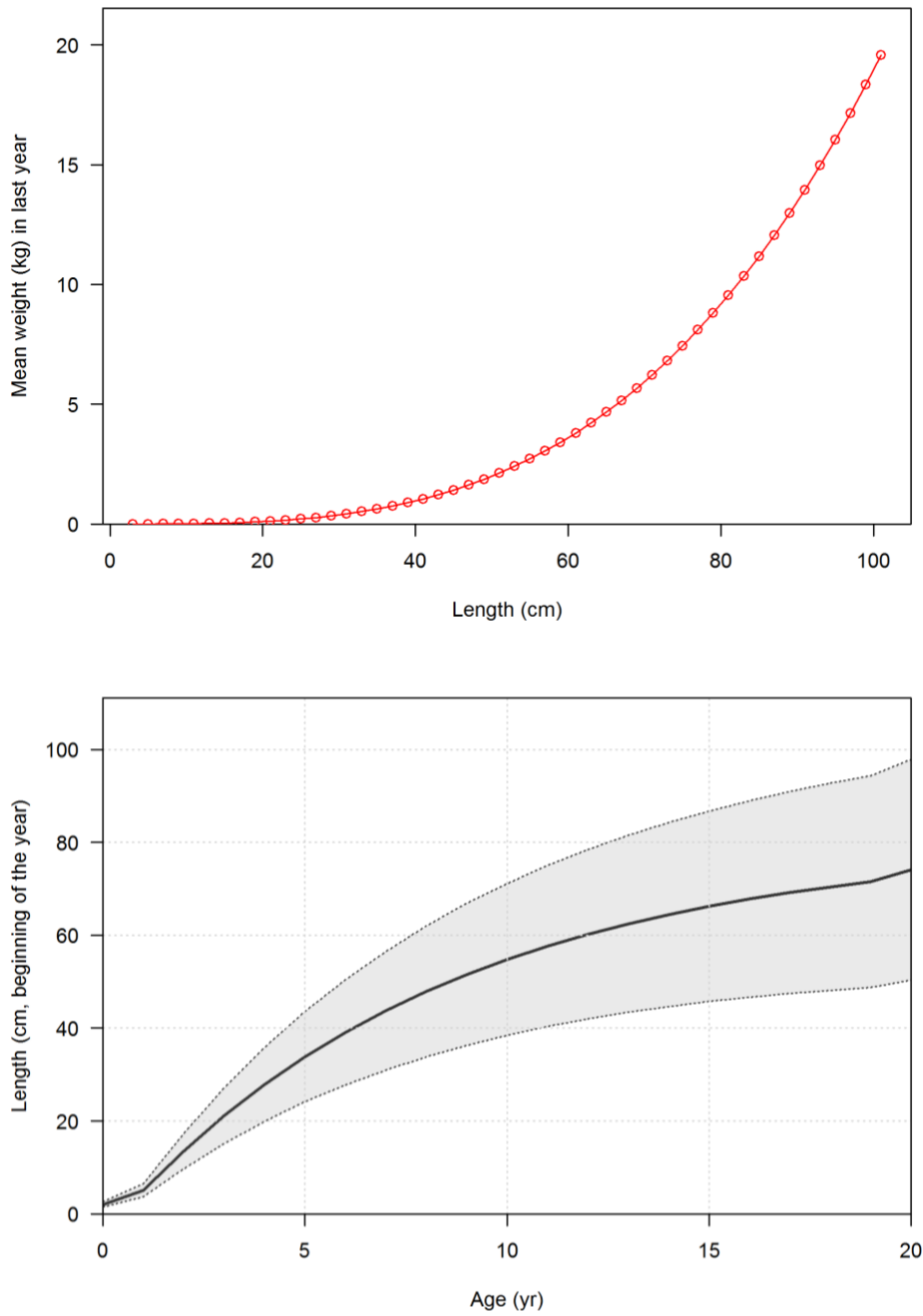
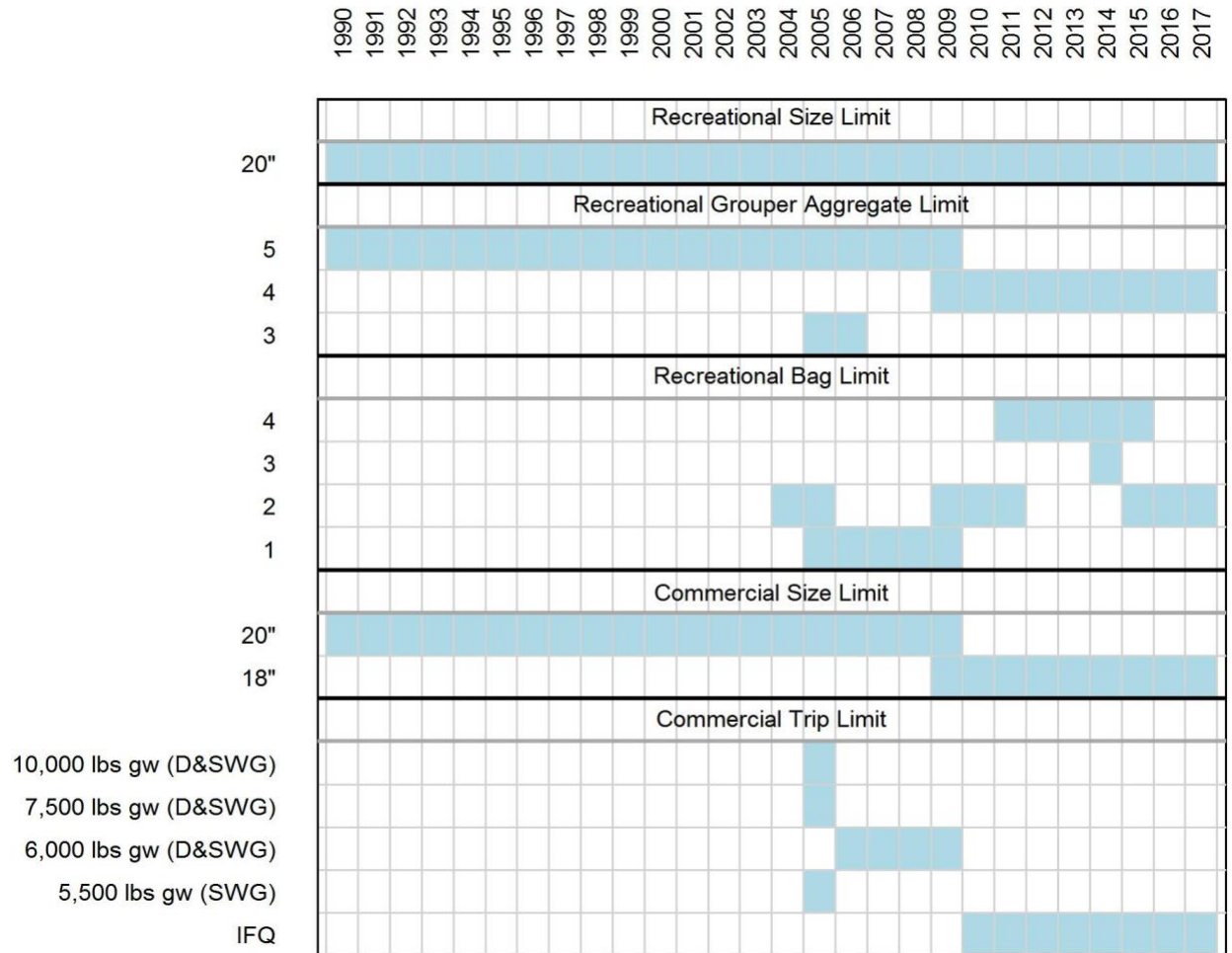


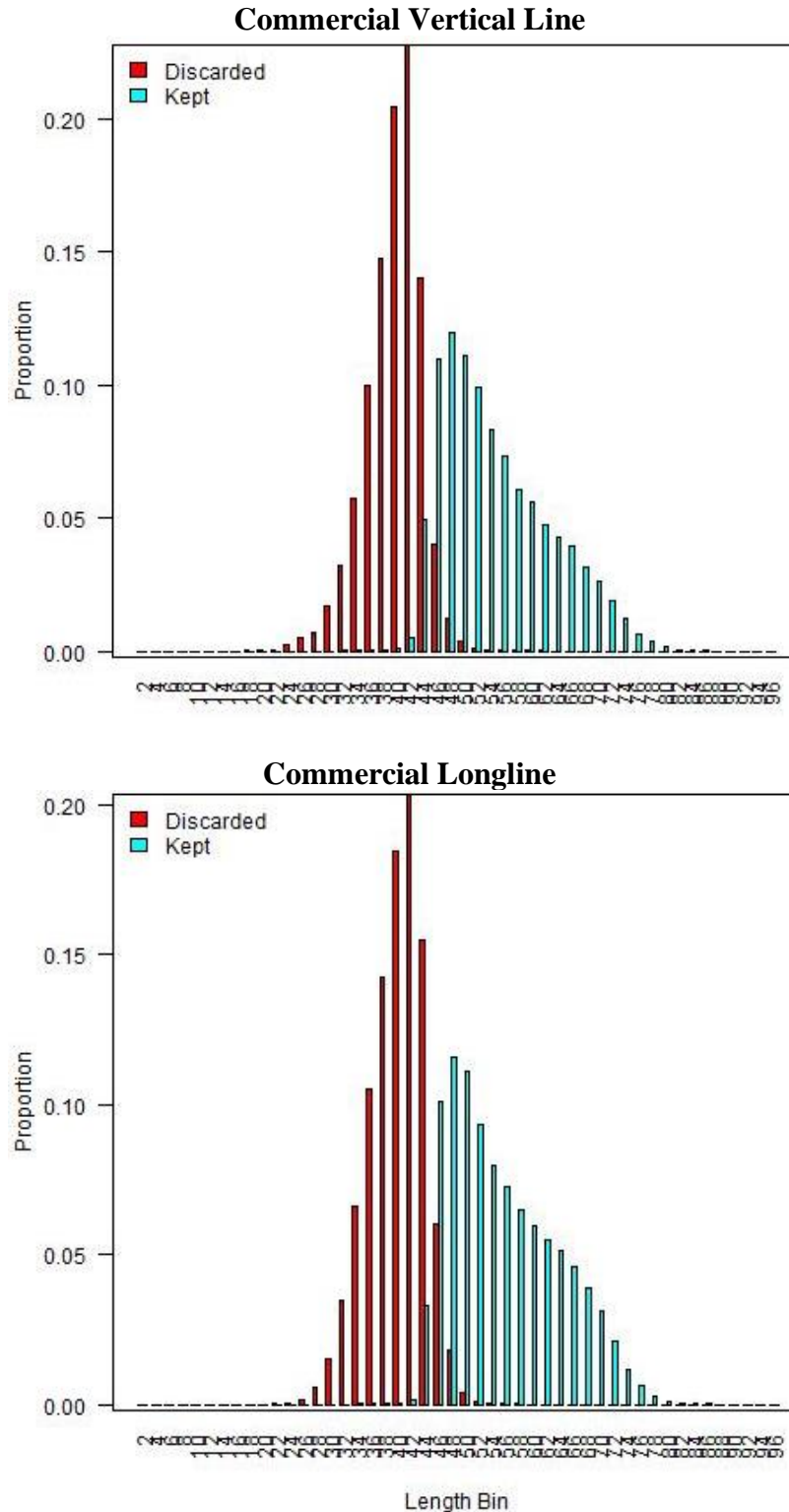
Figure 4.1. Data streams used in the SEDAR61 stock assessment model for Gulf of Mexico Red Grouper.



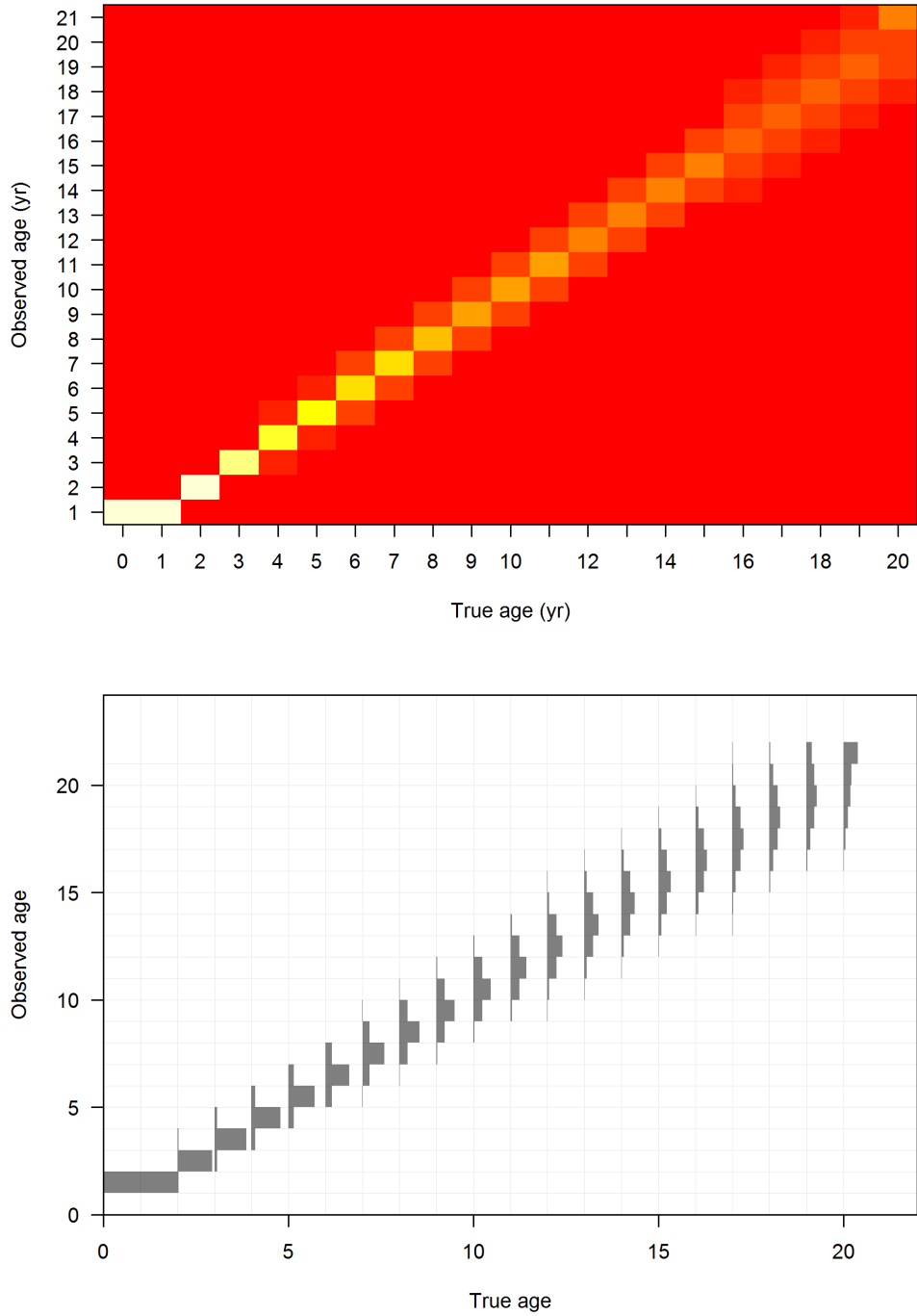
**Figure 4.2.** Mean weight at-length (Lower Panel) and the estimated growth curve (with 95% confidence intervals; top panel) for Gulf of Mexico Red Grouper.



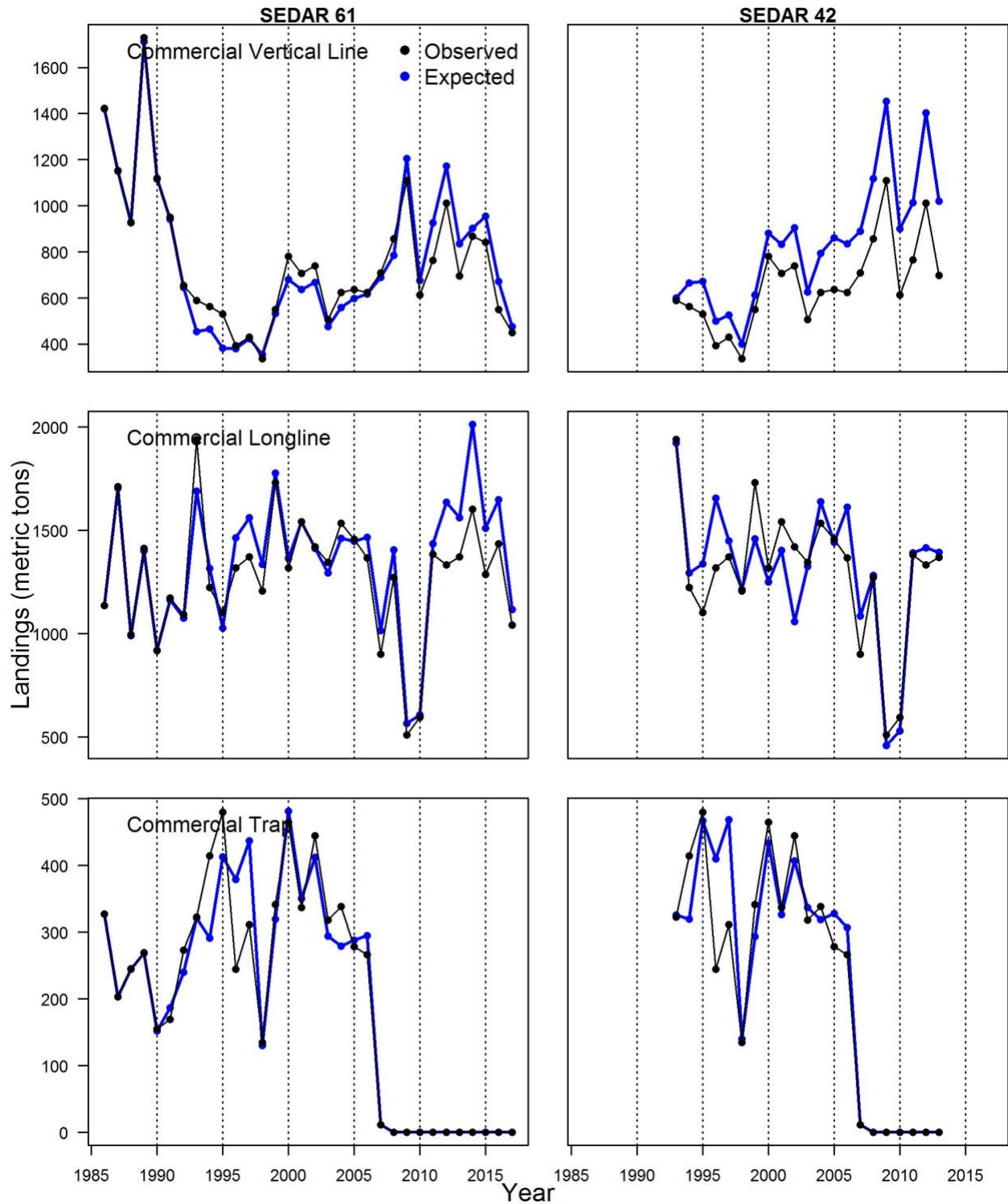
**Figure 4.3.** Summary of federal management regulations for Gulf of Mexico Red Grouper. Size limits are in inches Total Length and trip limits are in pounds gutted weight (lbs gw) for the Shallow-water Grouper complex (SWG) and Deep- and SWG complex (D&SWG). IFQ = Individual Fishing Quota.



**Figure 4.4.** The proportion of Gulf of Mexico Red Grouper discarded and kept between 2010 (implementation of IFQ) and 2017 for the Commercial Vertical Line (top panel) and Commercial Longline Fisheries (bottom panel). The size limit for 2009-2017 is 18 inches TL (43.969 cm FL).

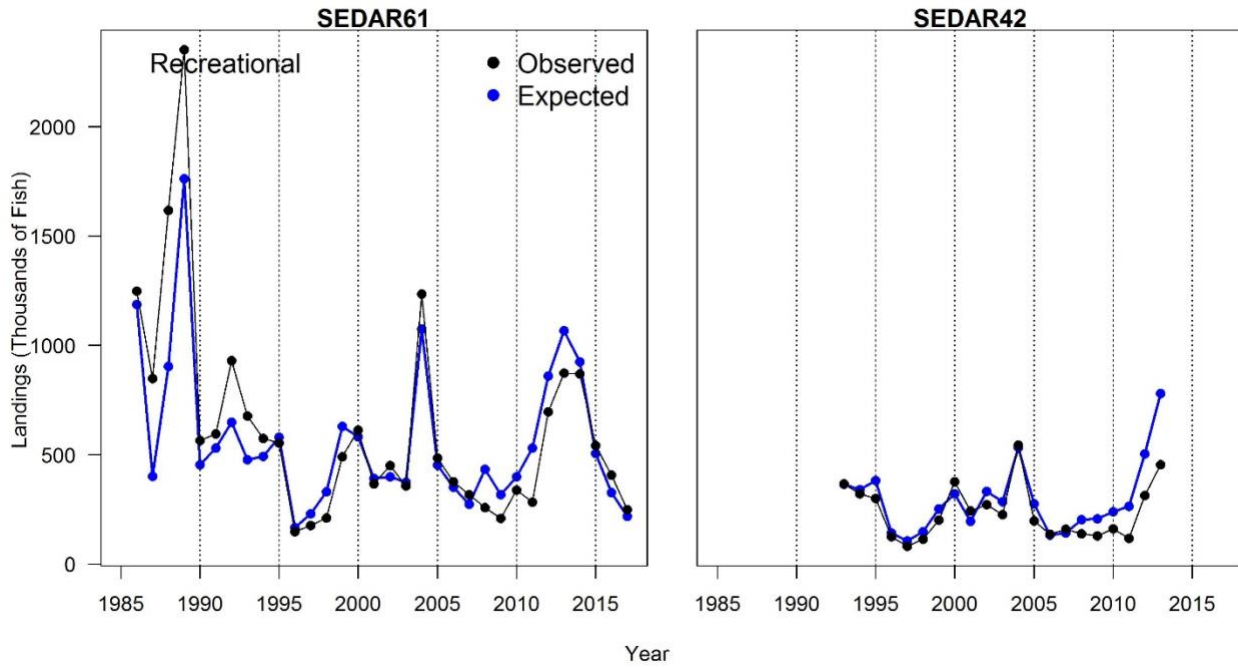


**Figure 4.5.** Aging imprecision matrix (Upper Panel) and resulting distribution of observed age at true age for Gulf of Mexico Red Grouper. Values in the aging imprecision matrix range from 0 (red) to 1 (white).

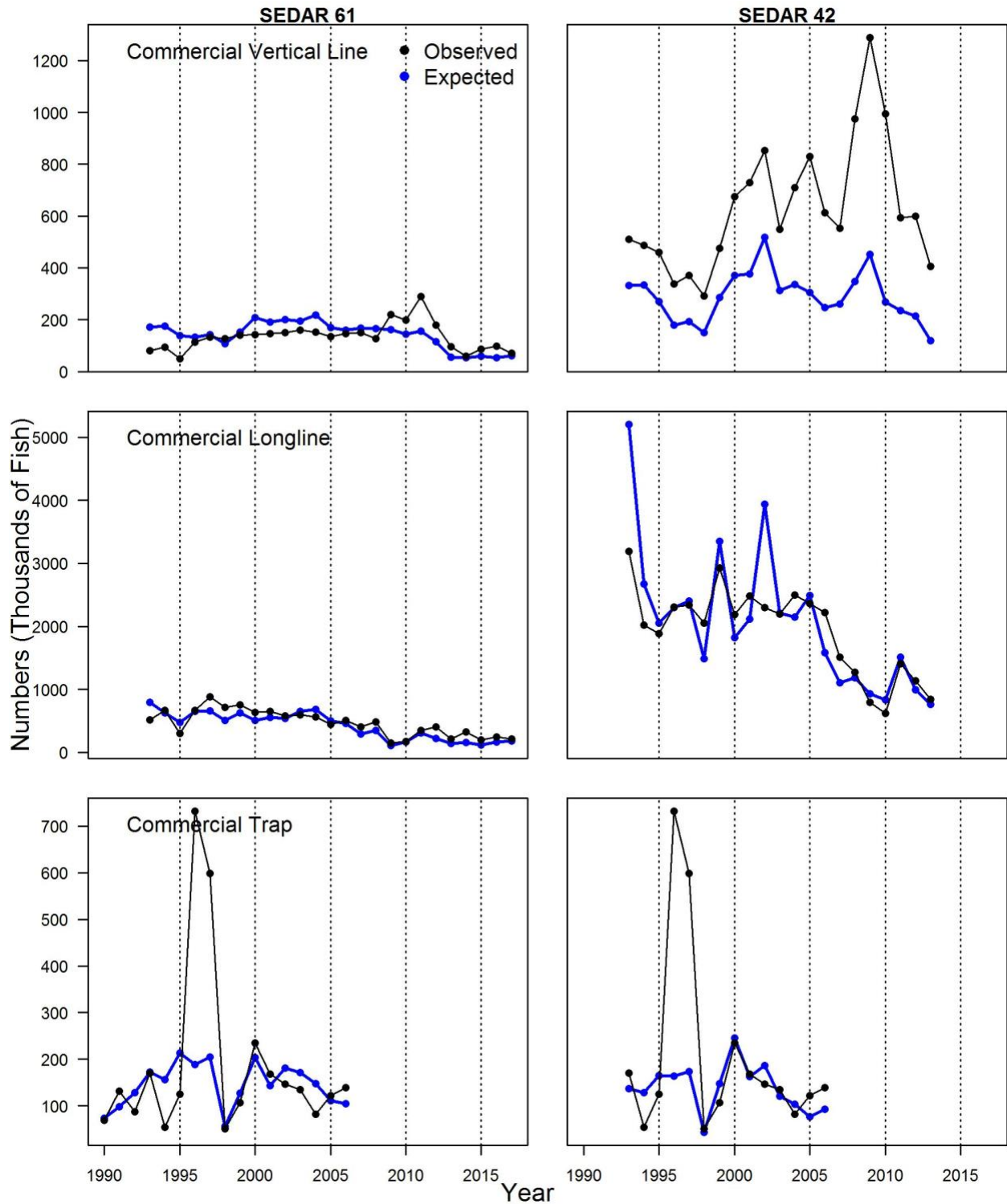


**Figure 4.6.** Gulf of Mexico Red Grouper observed and expected commercial landings by commercial fleet in metric tons for SEDAR61 (left panels) and SEDAR42 (right panels). Dashed vertical lines identify five year intervals starting in 1990.

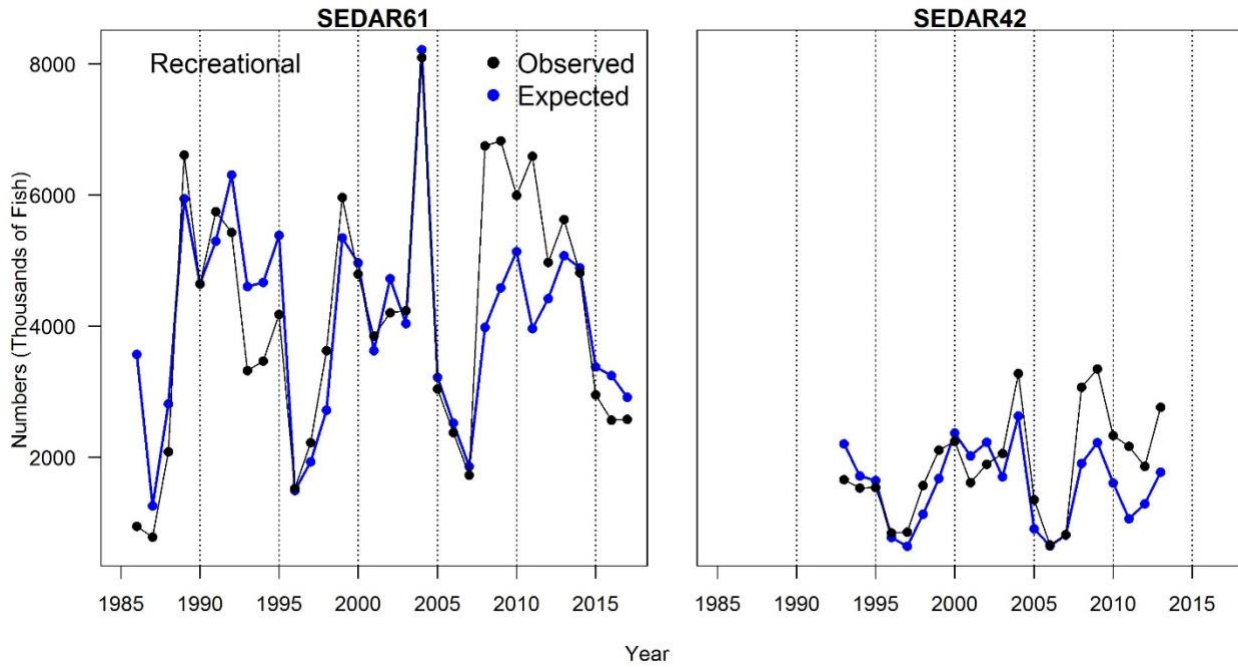




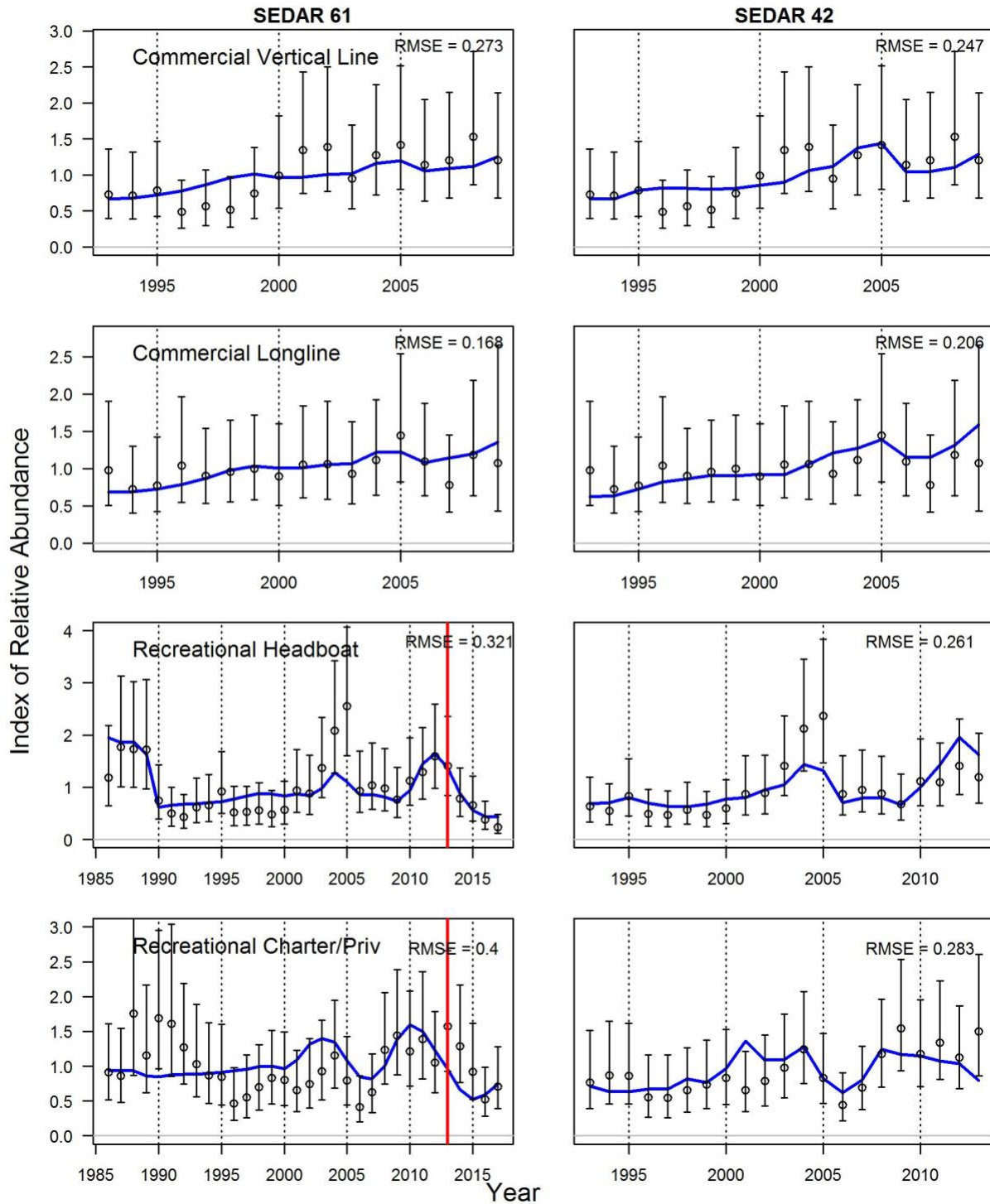
**Figure 4.7.** Gulf of Mexico Red Grouper observed and expected recreational landings for the recreational fleet in thousands of fish for SEDAR61 (left panel) and SEDAR42 (right panel). Dashed vertical lines identify five year intervals starting in 1990.



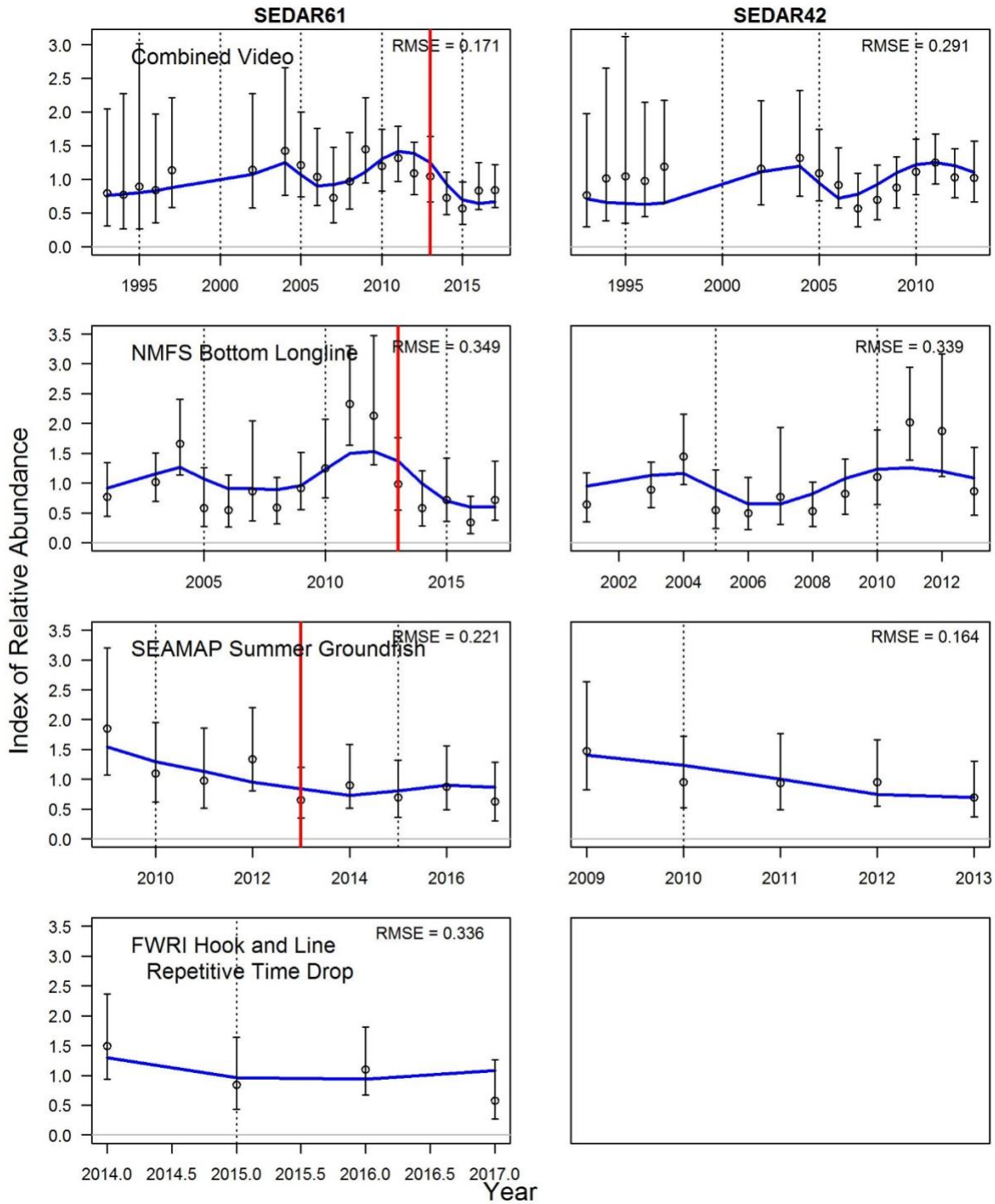
**Figure 4.8.** Gulf of Mexico Red Grouper observed and expected total commercial discards (i.e., before applying the discard mortality rate for each fleet) by commercial fleet in 1000s of Red Grouper for SEDAR61 (left panels) and SEDAR42 (right panels). Dashed vertical lines identify five year intervals starting in 1995.



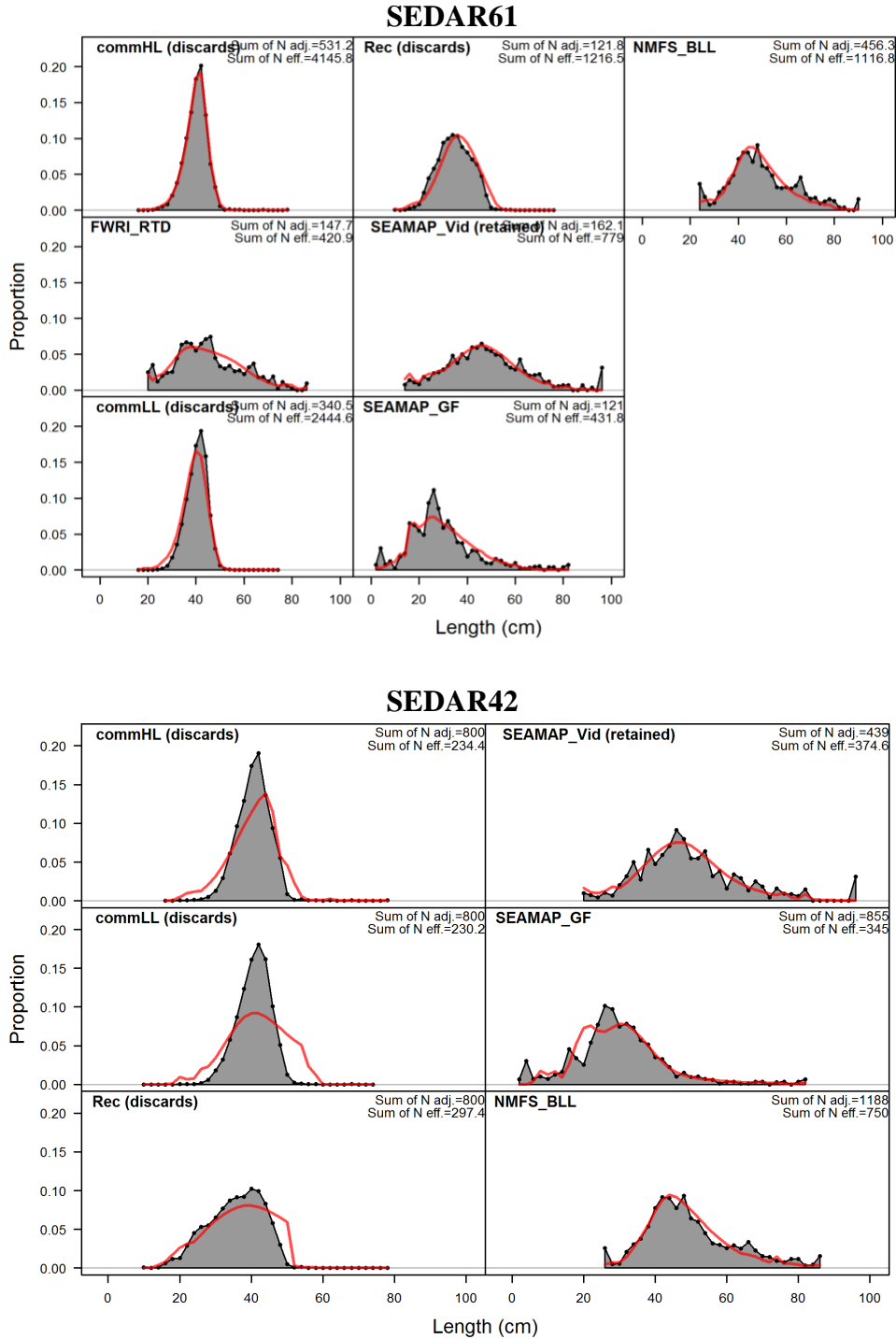
**Figure 4.9.** Gulf of Mexico Red Grouper observed and expected total recreational discards (i.e., before applying the discard mortality rate for each fleet) for the recreational fleet in 1000s of Red Grouper for SEDAR61 (left panel) and SEDAR42 (right panel). Dashed vertical lines identify five year intervals starting in 1990.



**Figure 4.10.** Gulf of Mexico Red Grouper observed (dots with 95% confidence intervals) and predicted (blue line) commercial CPUE indices of relative abundance by fleet for SEDAR61 (left panels) and SEDAR42 (right panels). The red line is used to identify the more recent time period of data available for SEDAR61, whereas dashed vertical lines identify five year intervals. The root mean squared error (RMSE) is also provided.

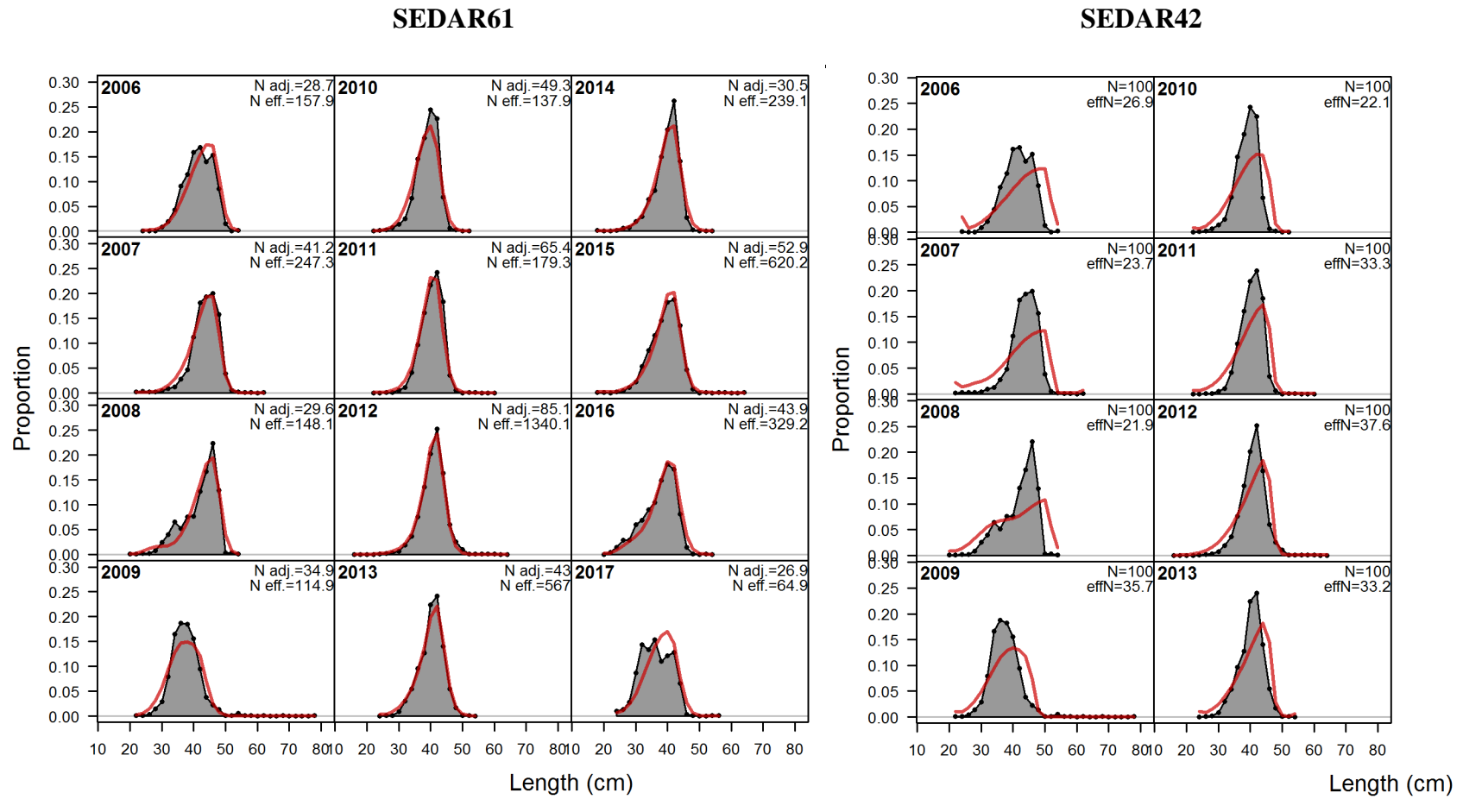


**Figure 4.11.** Gulf of Mexico Red Grouper observed (dots with 95% confidence intervals) and predicted (blue line) fishery-independent indices of relative abundance by fleet for SEDAR61 (left panels) and SEDAR42 (right panels). The red line is used to identify the more recent time period of data available for SEDAR61, whereas dashed vertical lines identify five year intervals. The root mean squared error (RMSE) is also provided.

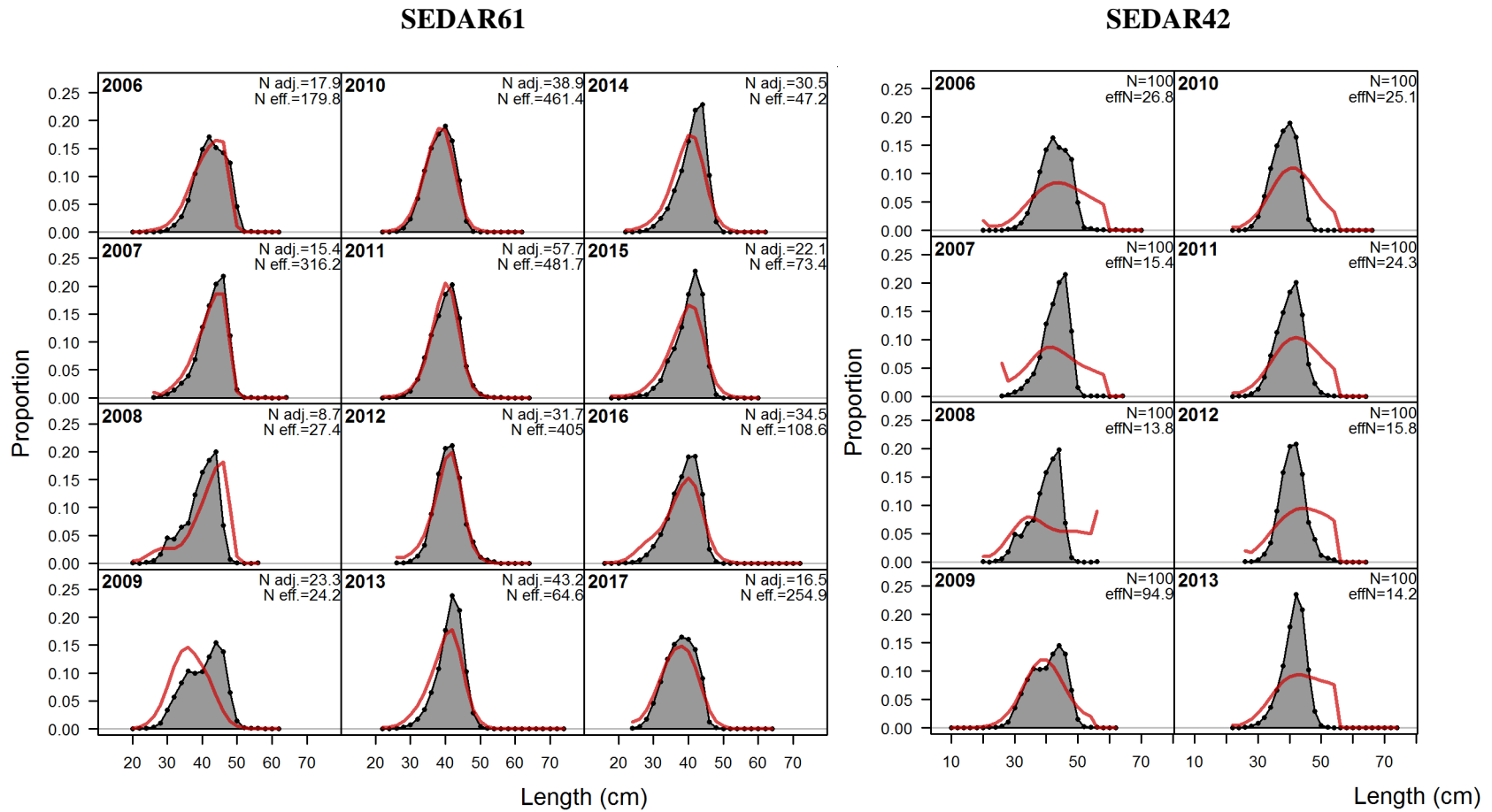


**Figure 4.12.** Model fits to the length composition of discarded or caught catch aggregated across years within a given fleet or survey for Gulf of Mexico Red Grouper. Red lines represent predicted length compositions, while grey shaded regions represent observed length compositions. The effective sample size used to weight the yearly length composition data is provided by N adj for SEDAR61 (Upper Panel) and N eff for SEDAR42 (Lower Panel) and shown in the upper right corner of each panel.



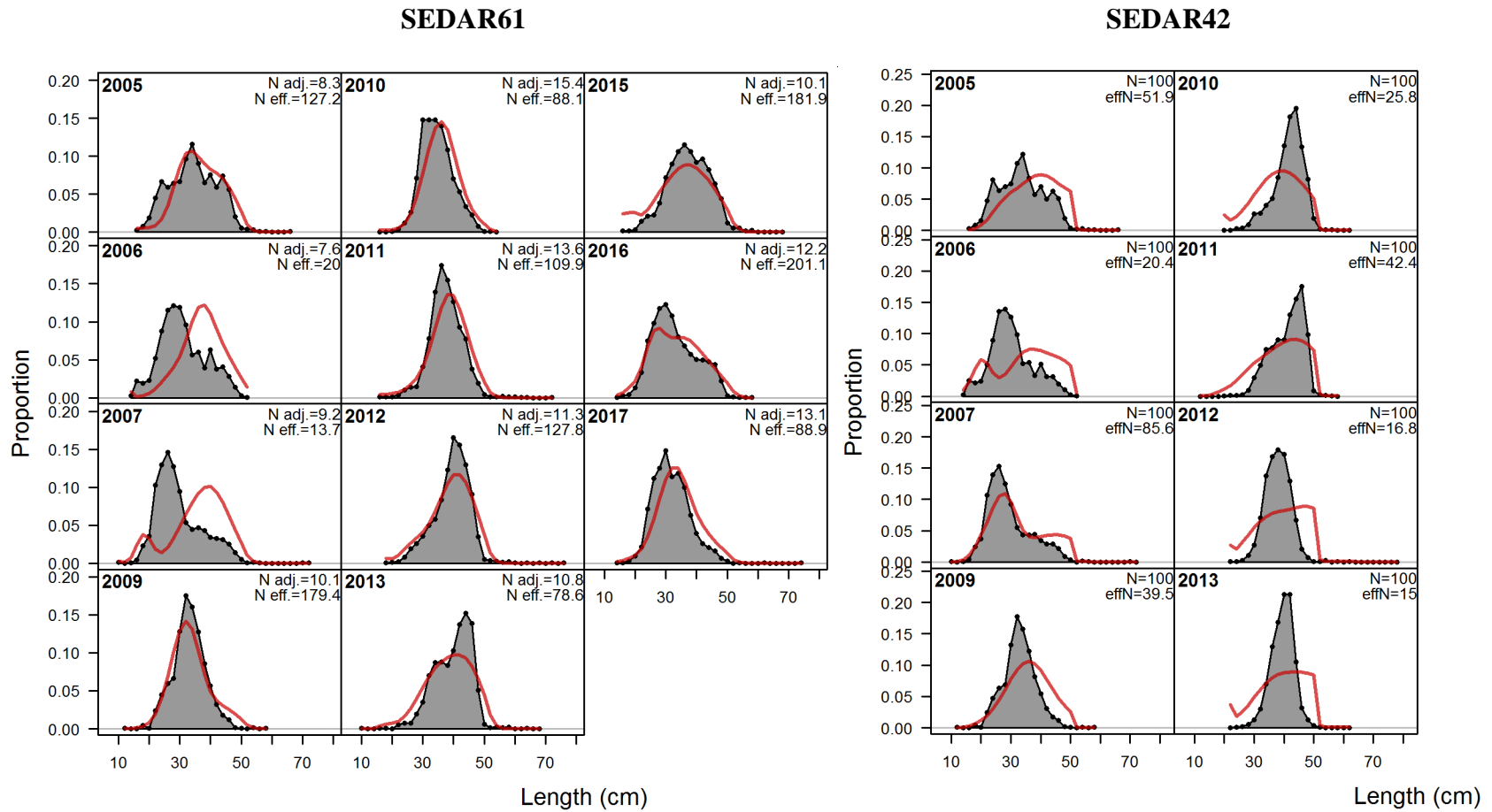


**Figure 4.13.** Model fits to the length composition of discarded catch by the commercial vertical line fleet for Gulf of Mexico Red Grouper. Red lines represent predicted length compositions, while grey shaded regions represent observed length compositions. The effective sample size used to weight the yearly length composition data is provided by N adj for SEDAR61 (left panel) and effN for SEDAR42 (right panel) and shown in the upper right corner of each panel.

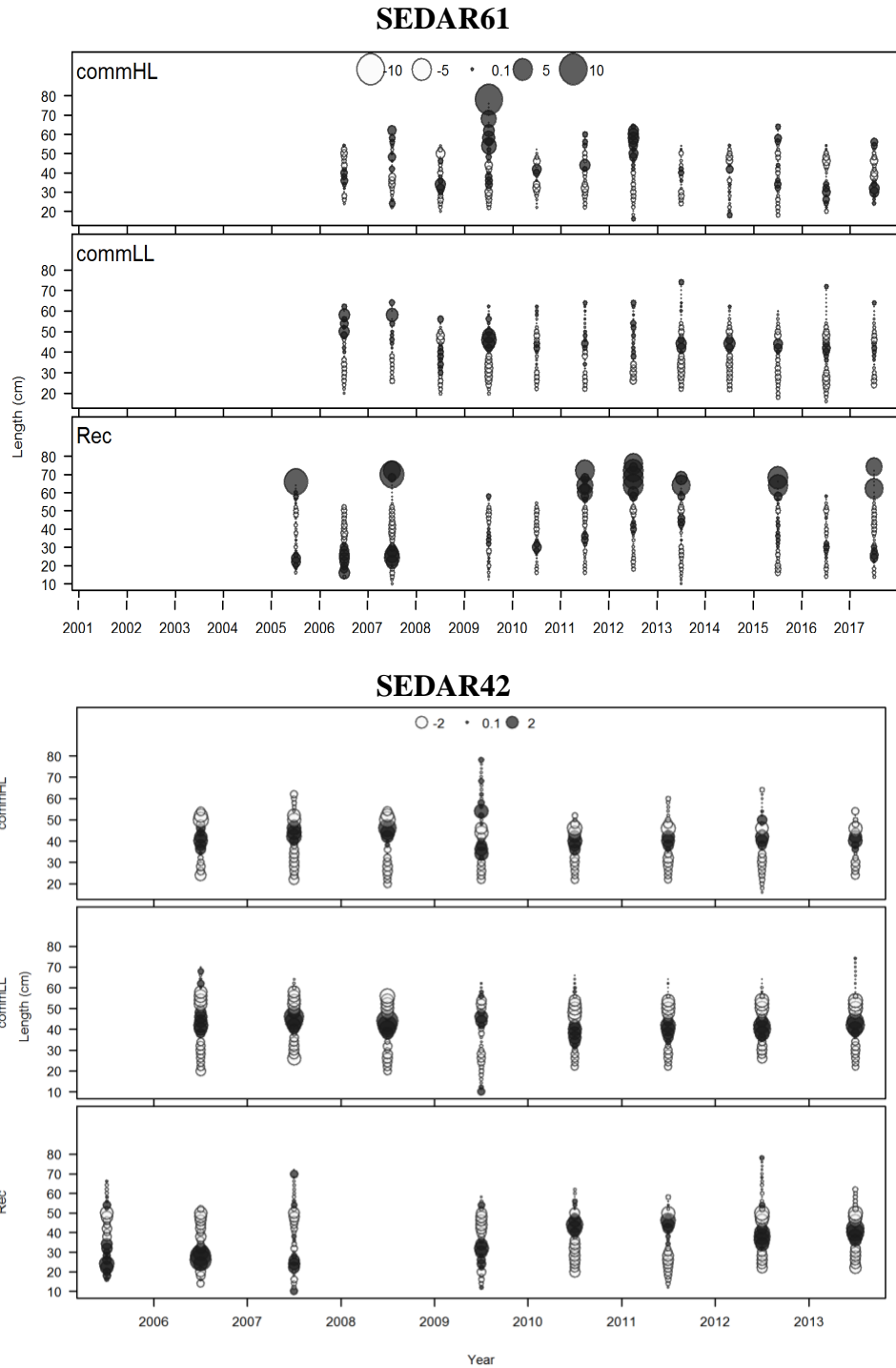


**Figure 4.14.** Model fits to the length composition of discarded catch by the commercial longline fleet for Gulf of Mexico Red Grouper. Red lines represent predicted length compositions, while grey shaded regions represent observed length compositions. The effective sample size used to weight the yearly length composition data is provided by N adj for SEDAR61 (left panel) and effN for SEDAR42 (right panel) and shown in the upper right corner of each panel.

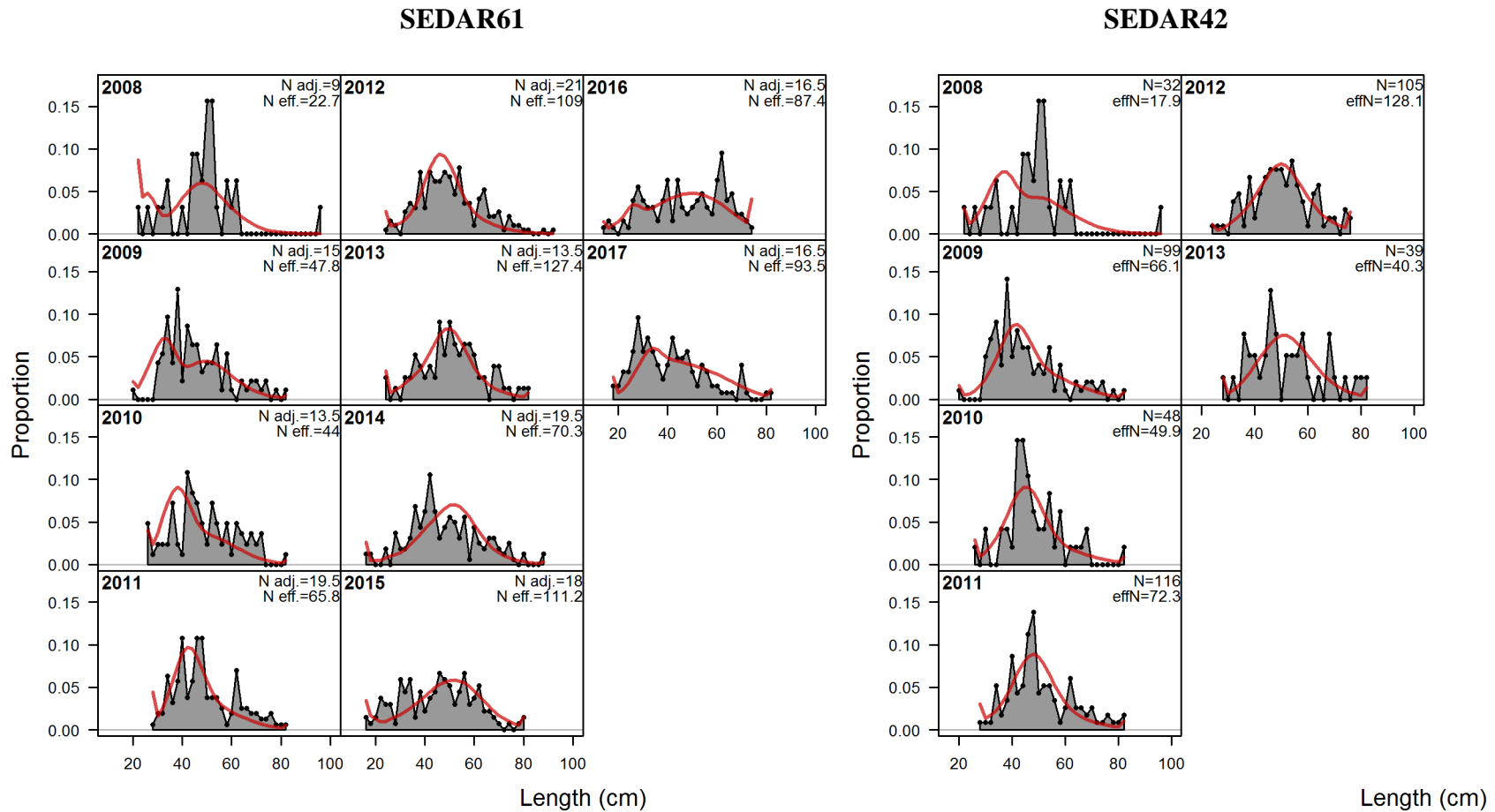




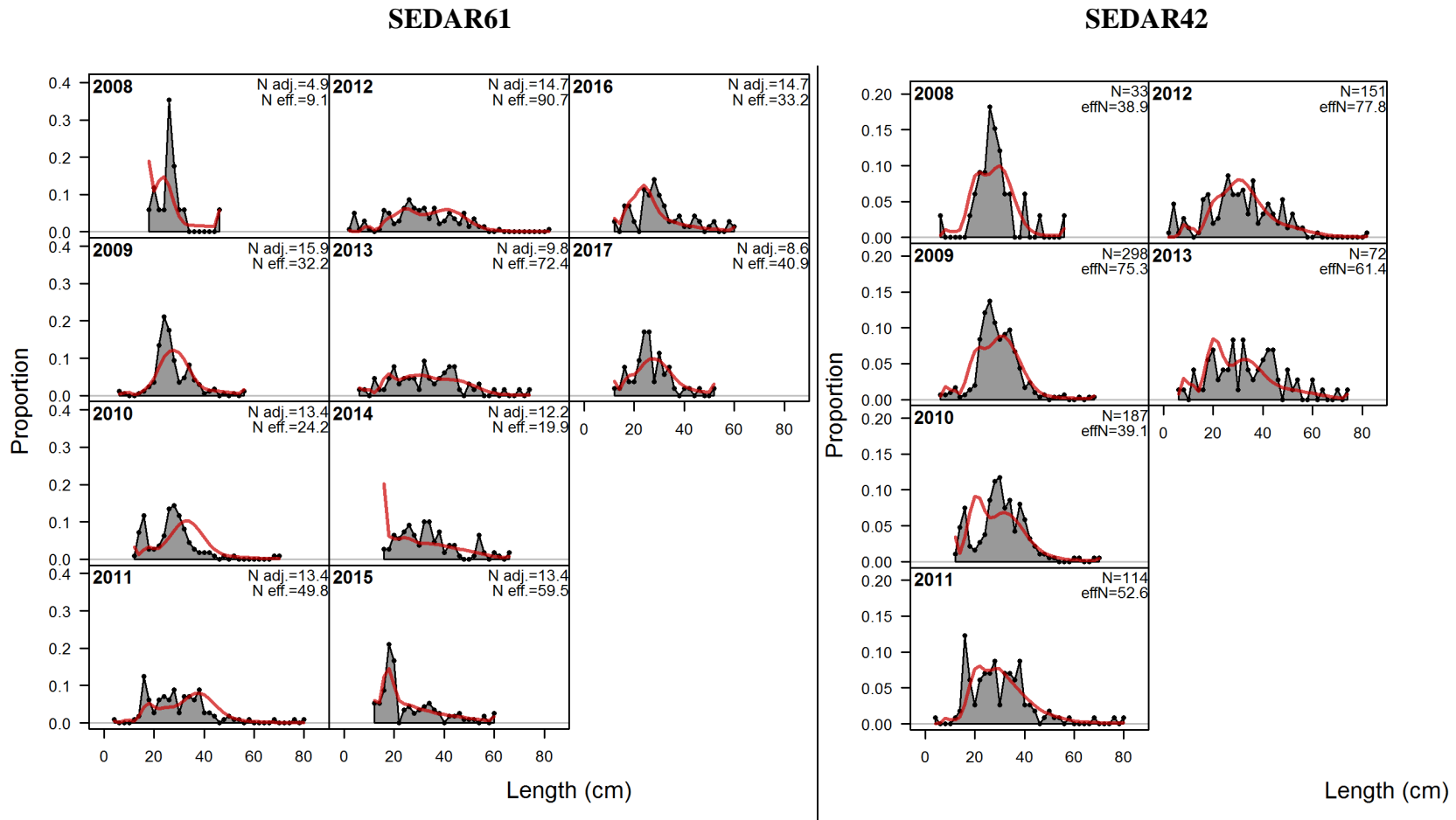
**Figure 4.15.** Model fits to the length composition of discarded catch by the recreational fleet for Gulf of Mexico Red Grouper. Red lines represent predicted length compositions, while grey shaded regions represent observed length compositions. The effective sample size used to weight the yearly length composition data is provided by N adj for SEDAR61 (left panel) and effN for SEDAR42 (right panel) and shown in the upper right corner of each panel.



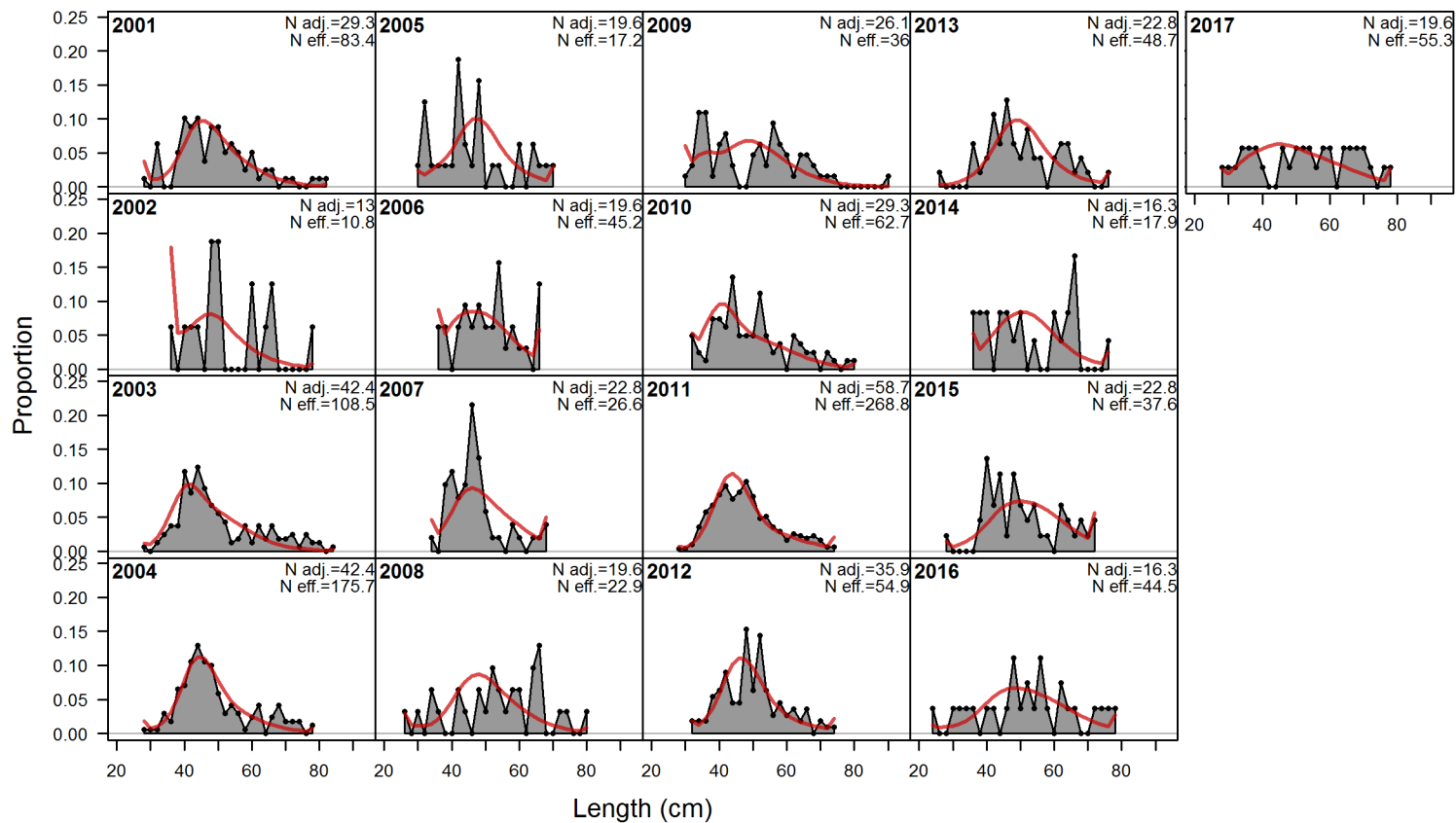
**Figure 4.16.** Pearson residuals for discard length composition data by year compared across fleets for Gulf of Mexico Red Grouper. Closed bubbles are positive residuals (observed > expected) and open bubbles are negative residuals (observed < expected). Results for SEDAR61 are in the Upper Panel and SEDAR42 results are in the Lower Panel.



**Figure 4.17.** Model fits to the length composition of catch by the Combined Video Survey for Gulf of Mexico Red Grouper. Red lines represent predicted length compositions, while grey shaded regions represent observed length compositions. The effective sample size used to weight the yearly length composition data is provided by N adj for SEDAR61 (left panel) and effN for SEDAR42 (right panel) and shown in the upper right corner of each panel.

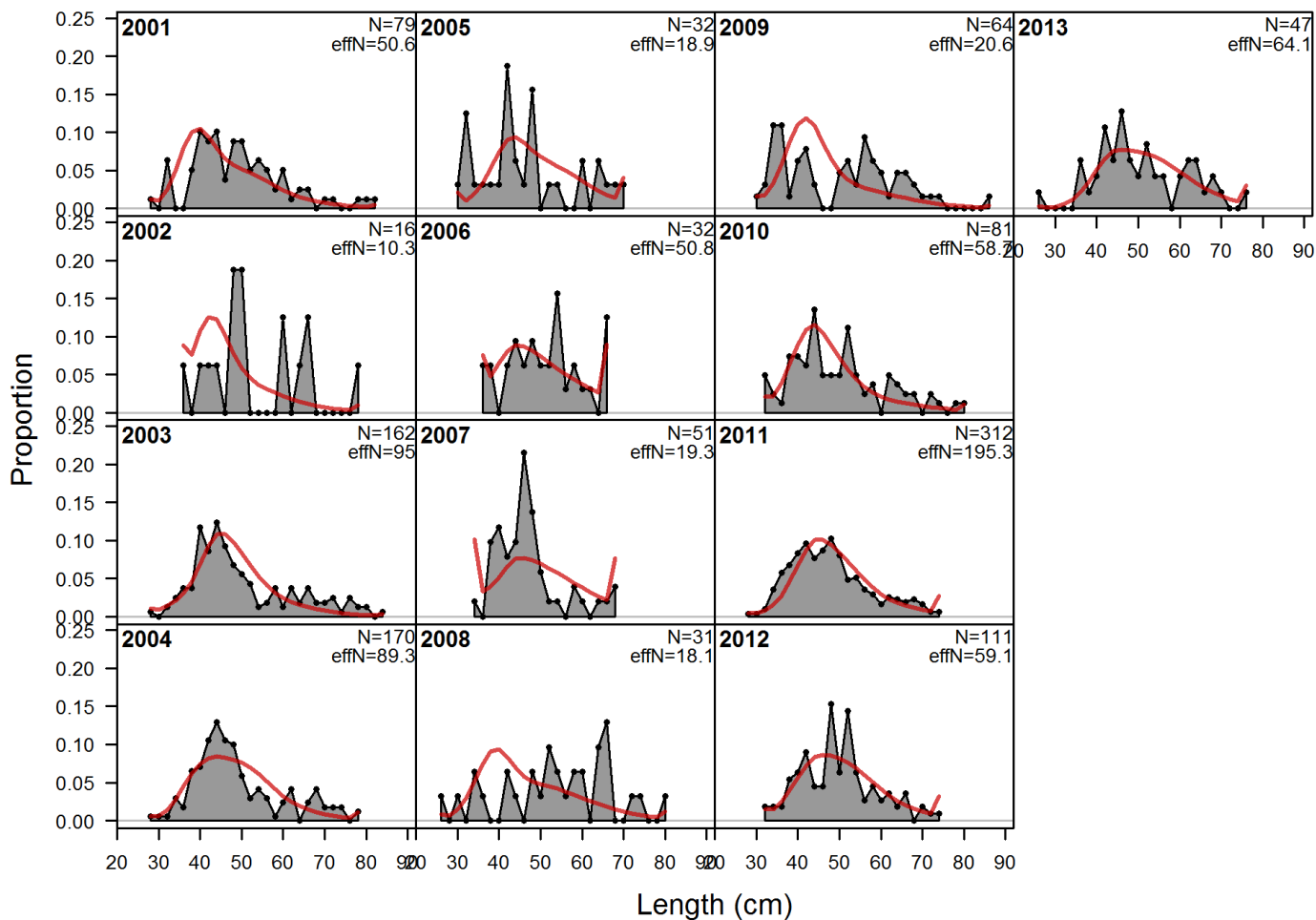


**Figure 4.18.** Model fits to the length composition of survey catch by the SEAMAP Summer Groundfish Survey for Gulf of Mexico Red Grouper. Red lines represent predicted length compositions, while grey shaded regions represent observed length compositions. The effective sample size used to weight the yearly length composition data is provided by N adj for SEDAR61 (left panel) and effN for SEDAR42 (right panel) and shown in the upper right corner of each panel.



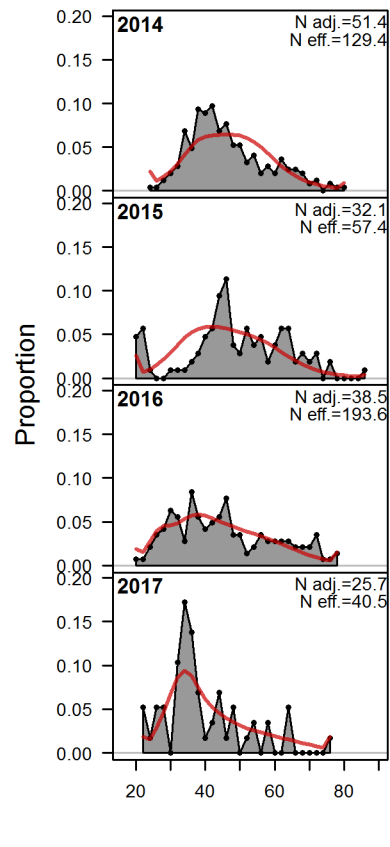
**Figure 4.19.** Model fits to the length composition of survey catch by the NMFS Bottom Longline Survey for Gulf of Mexico Red Grouper. Red lines represent predicted length compositions, while grey shaded regions represent observed length compositions. The effective sample size used to weight the yearly length composition data is provided by N adj for SEDAR61 and effN for SEDAR42 (next page) and shown in the upper right corner of each panel.

**SEDAR42**

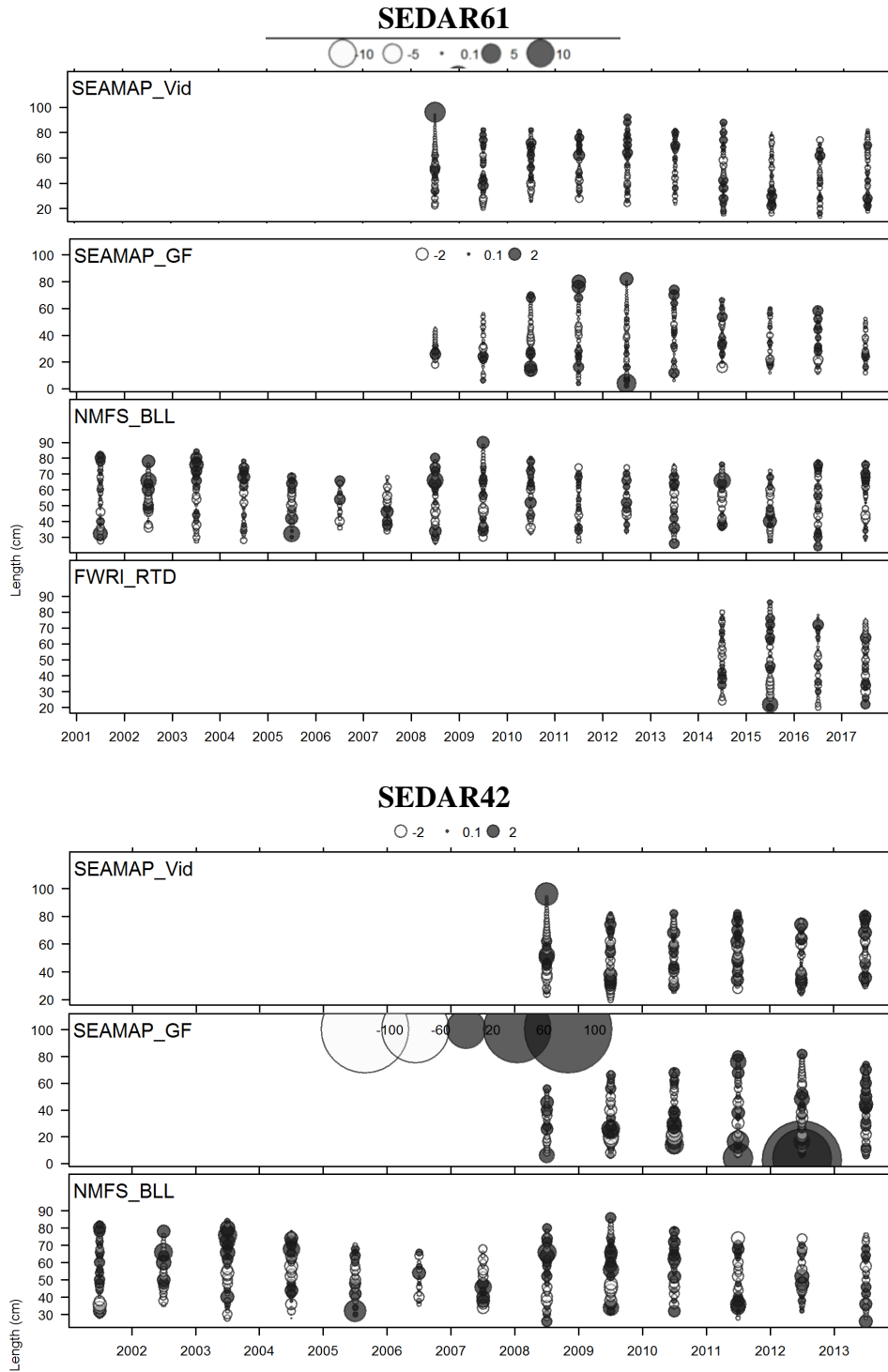


**Figure 4.19. Continued** Model fits to the length composition of survey catch by the NMFS Bottom Longline Survey for Gulf of Mexico Red Grouper.

**SEDAR61**

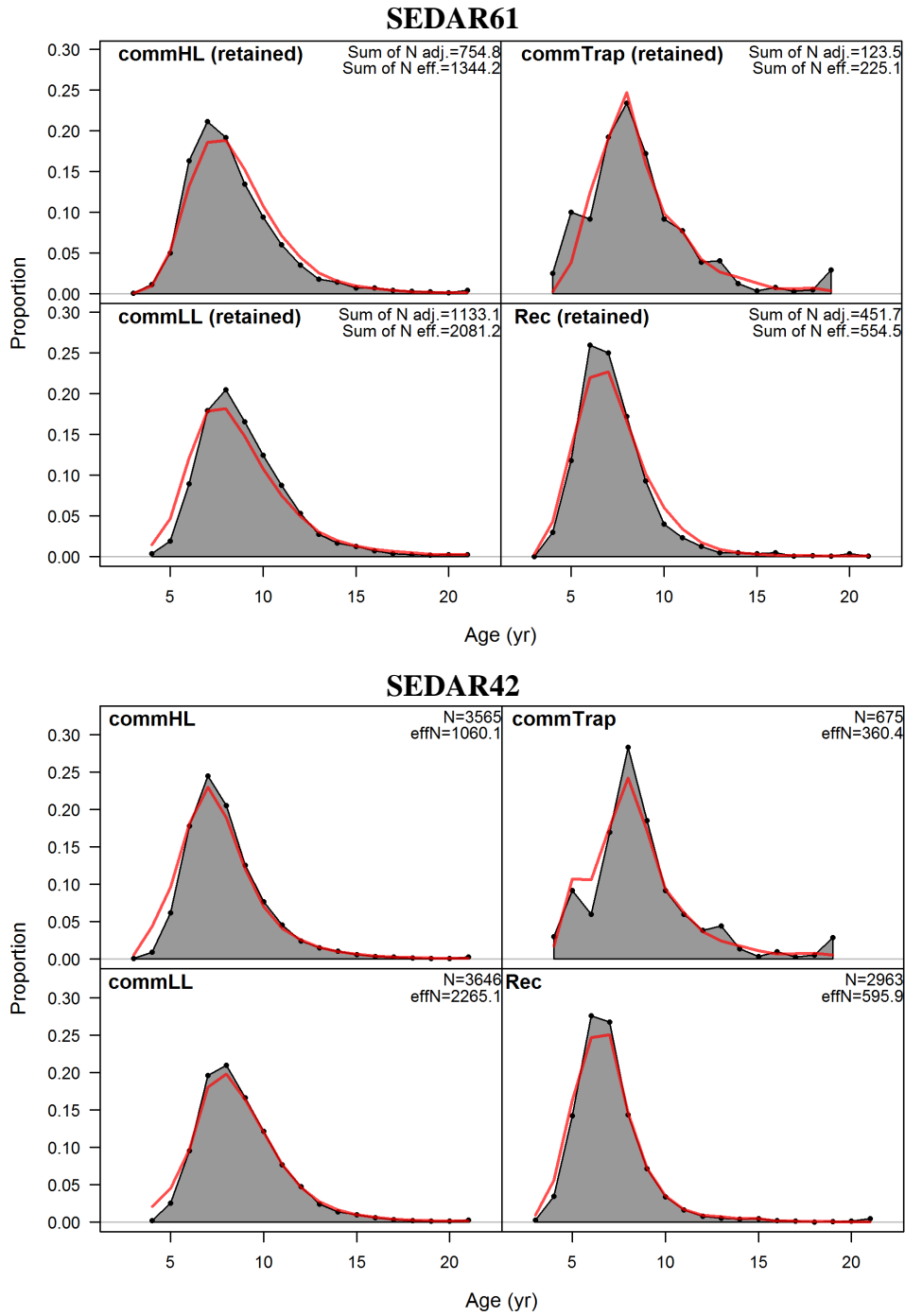


**Figure 4.20.** Model fits to the length composition of survey catch by the FWRI Hook and Line Repetitive Time Drop Survey for Gulf of Mexico Red Grouper. Red lines represent predicted length compositions, while grey shaded regions represent observed length compositions. The effective sample size used to weight the yearly length composition data is provided by the N adj for SEDAR61 and shown in the upper right corner of each panel. This data stream was not available for SEDAR42.

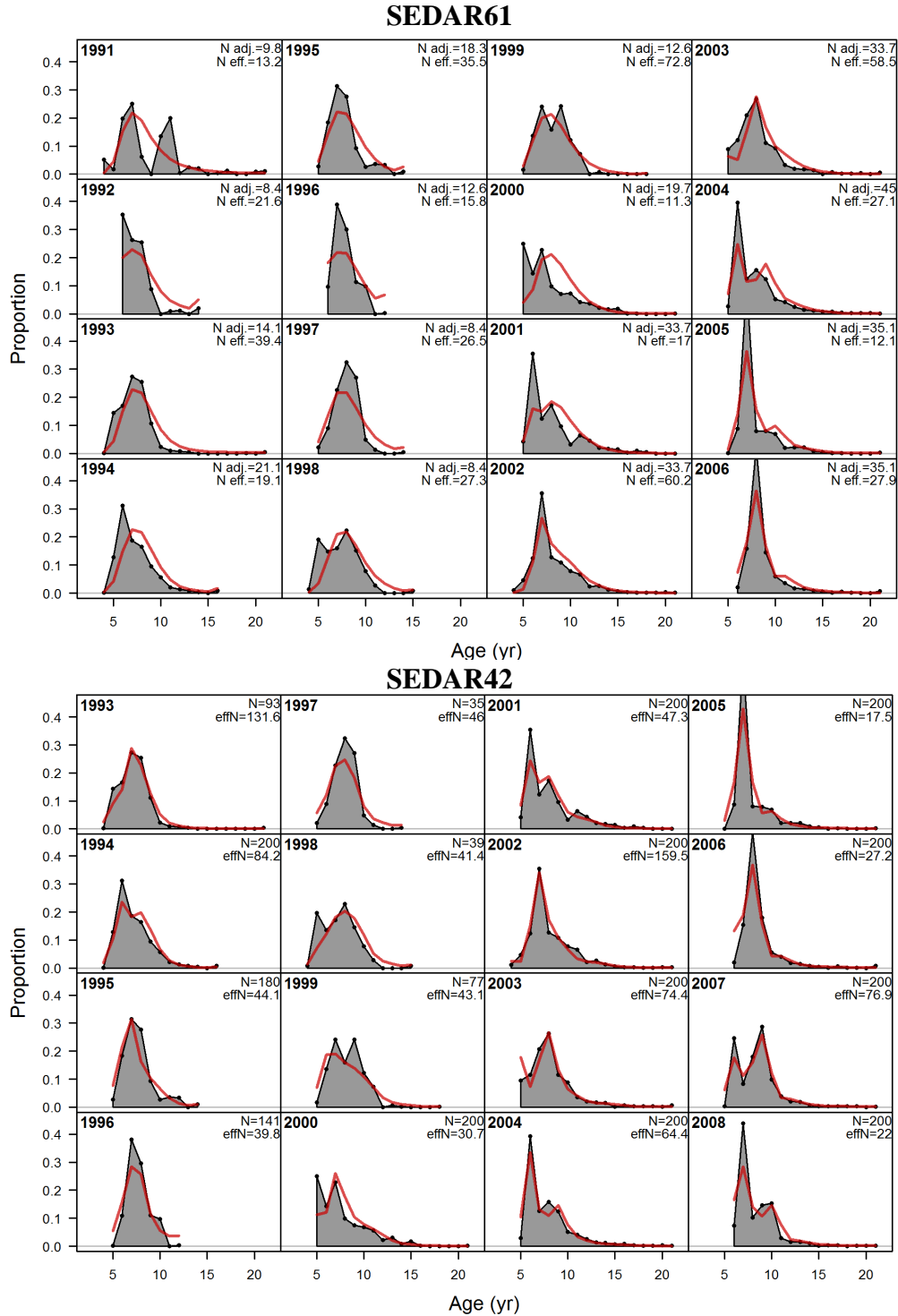


**Figure 4.21.** Pearson residuals for survey length composition data by year compared across surveys for Gulf of Mexico Red Grouper. Closed bubbles are positive residuals (observed > expected) and open bubbles are negative residuals (observed < expected). Results for SEDAR61 are in the Upper Panel and SEDAR42 results are in the Lower Panel.

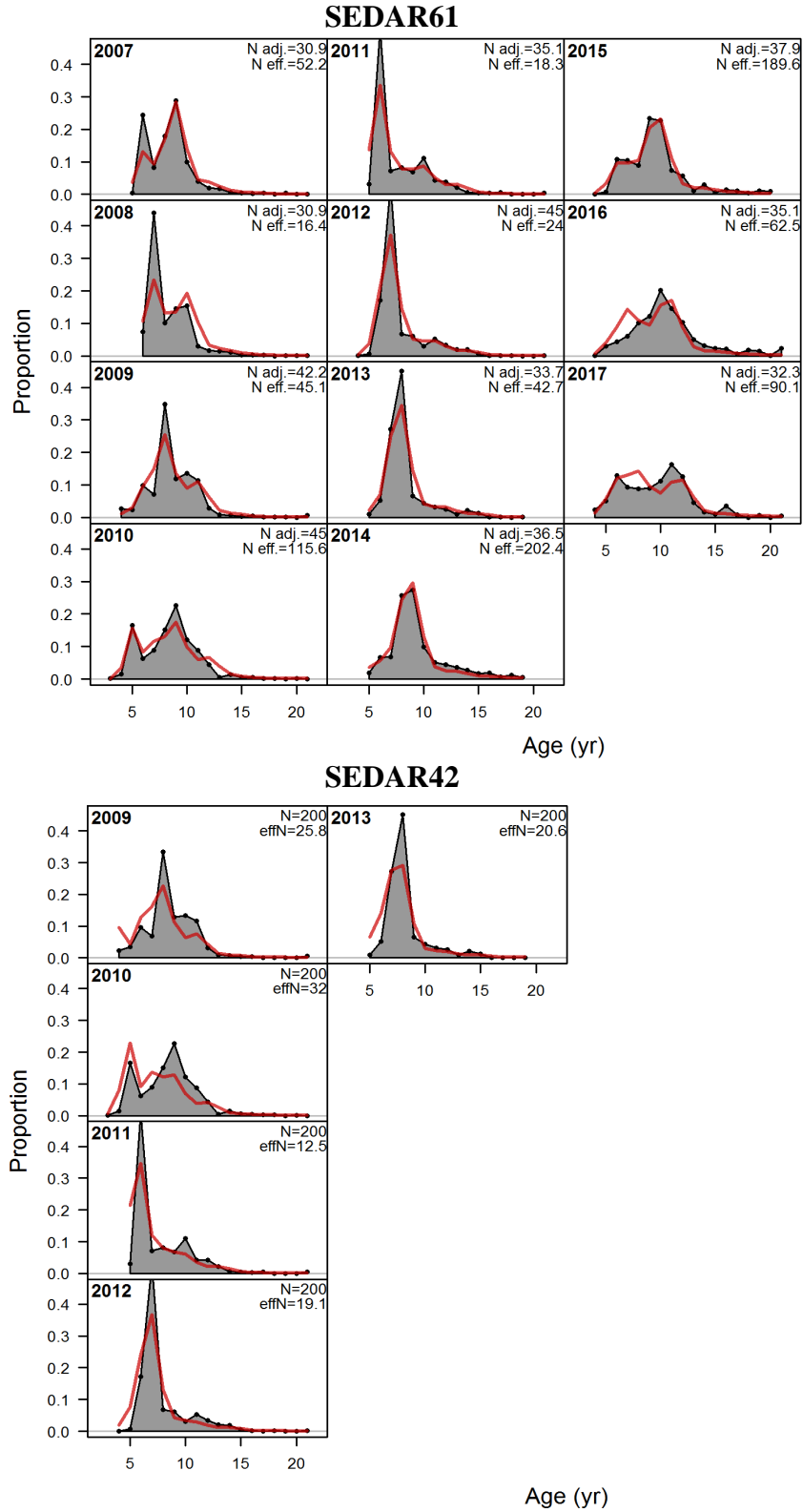




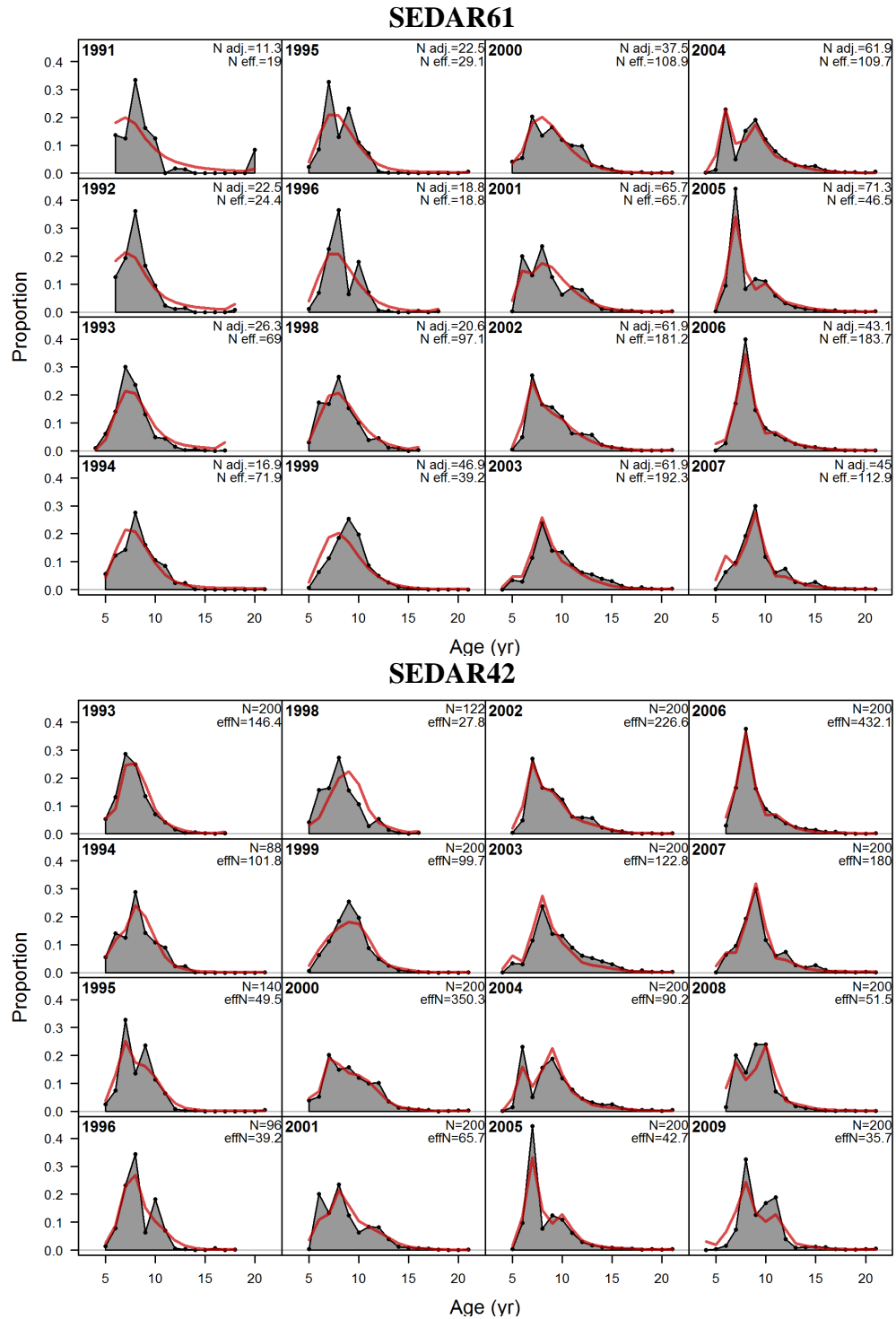
**Figure 4.22.** Model fits to the age composition of retained catch aggregated across years within a given fleet for Gulf of Mexico Red Grouper. Red lines represent predicted age compositions, while grey shaded regions represent observed age compositions. The effective sample size used to weight the yearly age composition data is provided by N adj for SEDAR61 (Upper Panel) and effN for SEDAR42 (Lower Panel) and shown in the upper right corner of each panel.



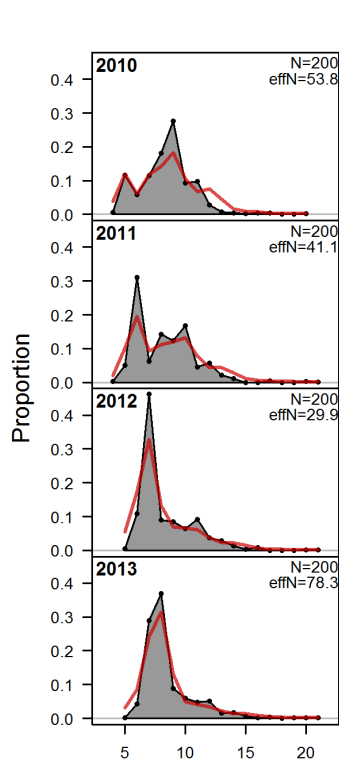
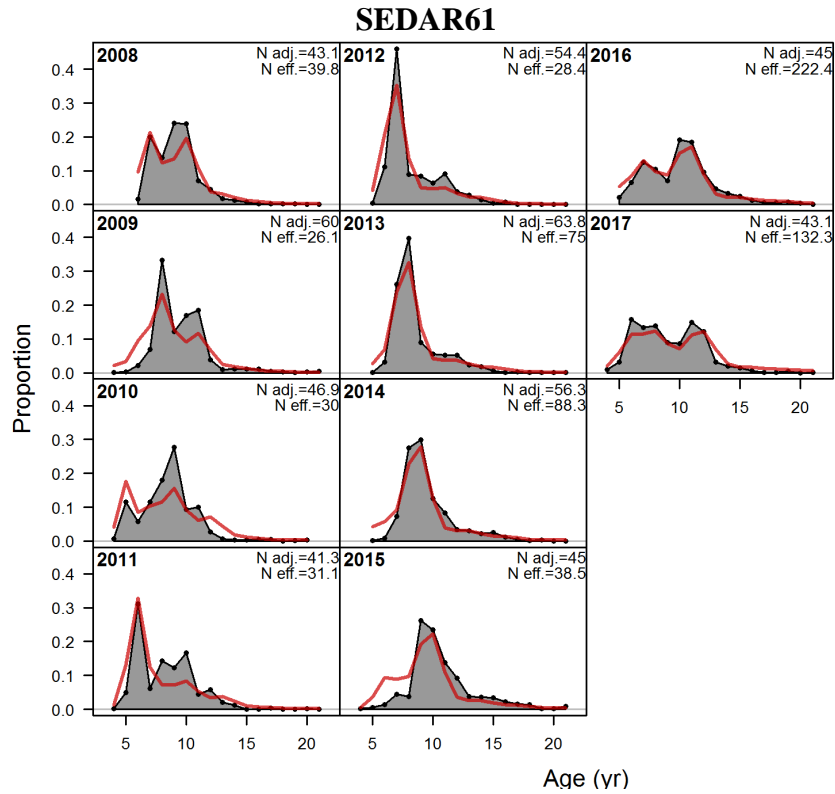
**Figure 4.23.** Model fits to the age composition of retained catch by the commercial vertical line fleet for Gulf of Mexico Red Grouper. Red lines represent predicted age compositions, while grey shaded regions represent observed age compositions. The effective sample size used to weight the yearly age composition data is provided by N adj for SEDAR61 (Upper Panel) and effN for SEDAR42 (Lower Panel) and shown in the upper right corner of each panel.



**Figure 4.23. Continued.** Model fits to the age composition of retained catch by the commercial vertical line fleet for Gulf of Mexico Red Grouper.

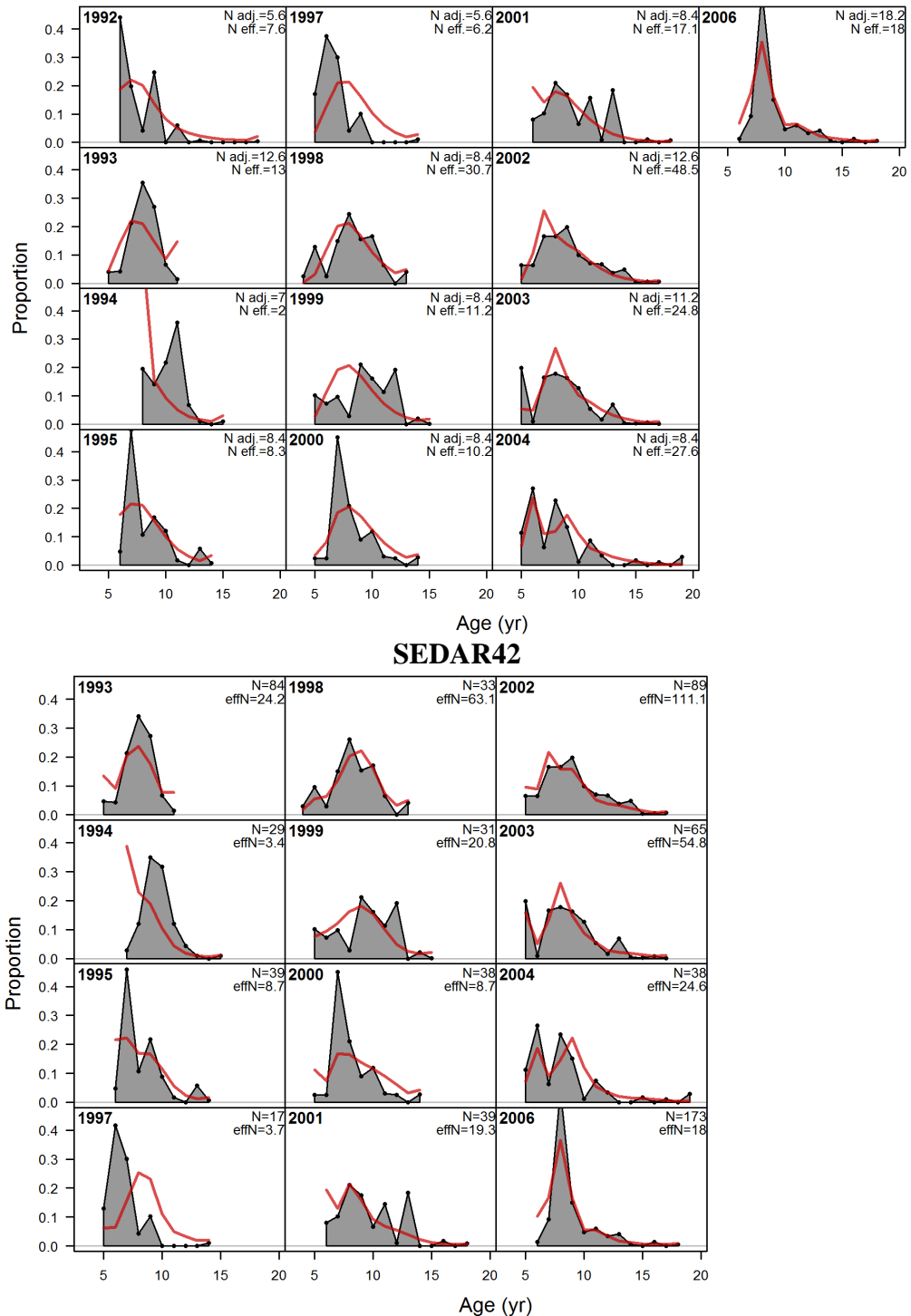


**Figure 4.24.** Model fits to the age composition of retained catch by the commercial longline fleet for Gulf of Mexico Red Grouper. Red lines represent predicted age compositions, while grey shaded regions represent observed age compositions. The effective sample size used to weight the yearly age composition data is provided by N adj for SEDAR61 (Upper Panel) and effN for SEDAR42 (Lower Panel) and shown in the upper right corner of each panel.



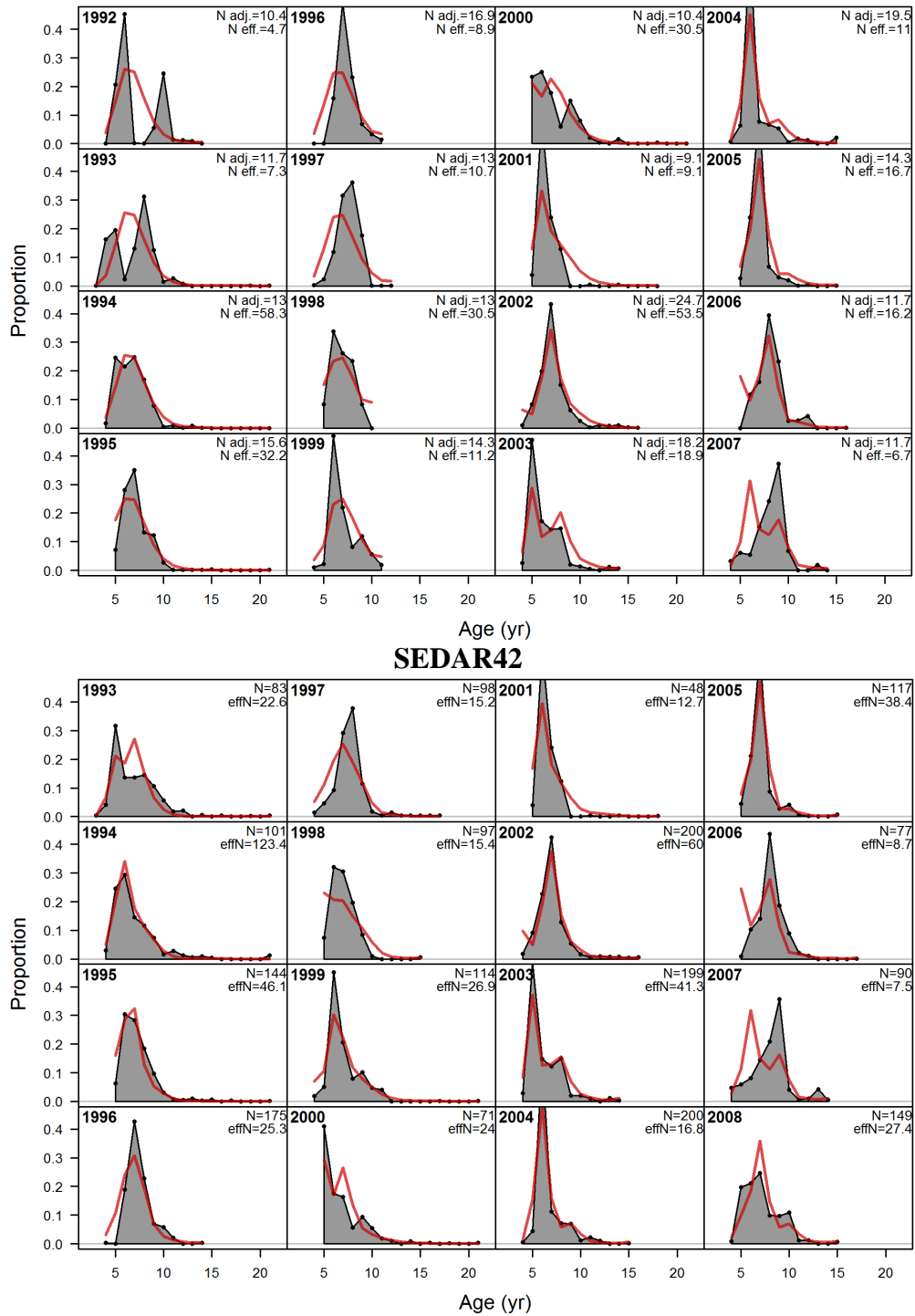
**Figure 4.24. Continued** Model fits to the age composition of retained catch by the commercial longline fleet for Gulf of Mexico Red Grouper.

**SEDAR61**

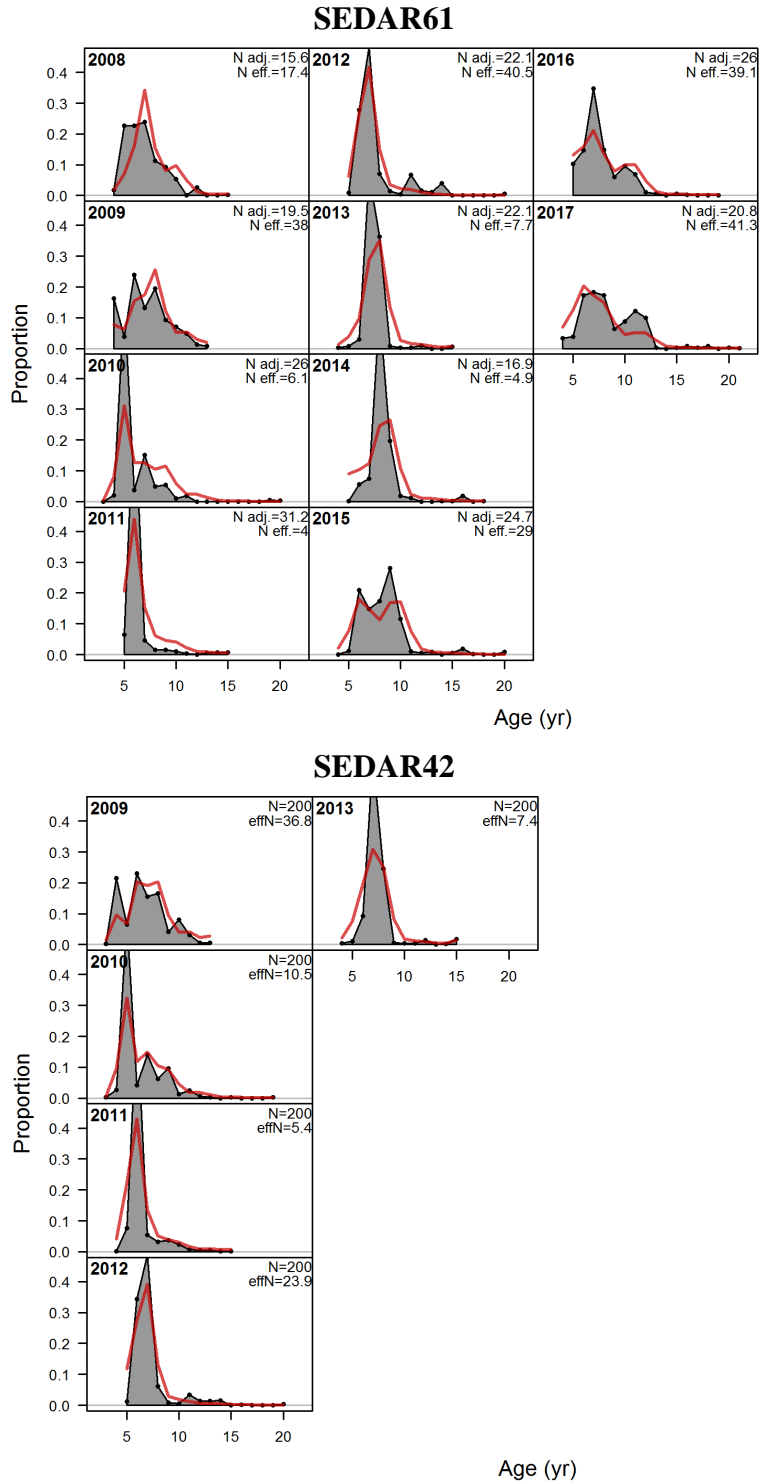


**Figure 4.25.** Model fits to the age composition of retained catch by the commercial trap fleet for Gulf of Mexico Red Grouper. Red lines represent predicted age compositions, while grey shaded regions represent observed age compositions. The effective sample size used to weight the yearly age composition data is provided by N adj for SEDAR61 (Upper Panel) and effN for SEDAR42 (Lower Panel) and shown in the upper right corner of each panel.

**SEDAR61**

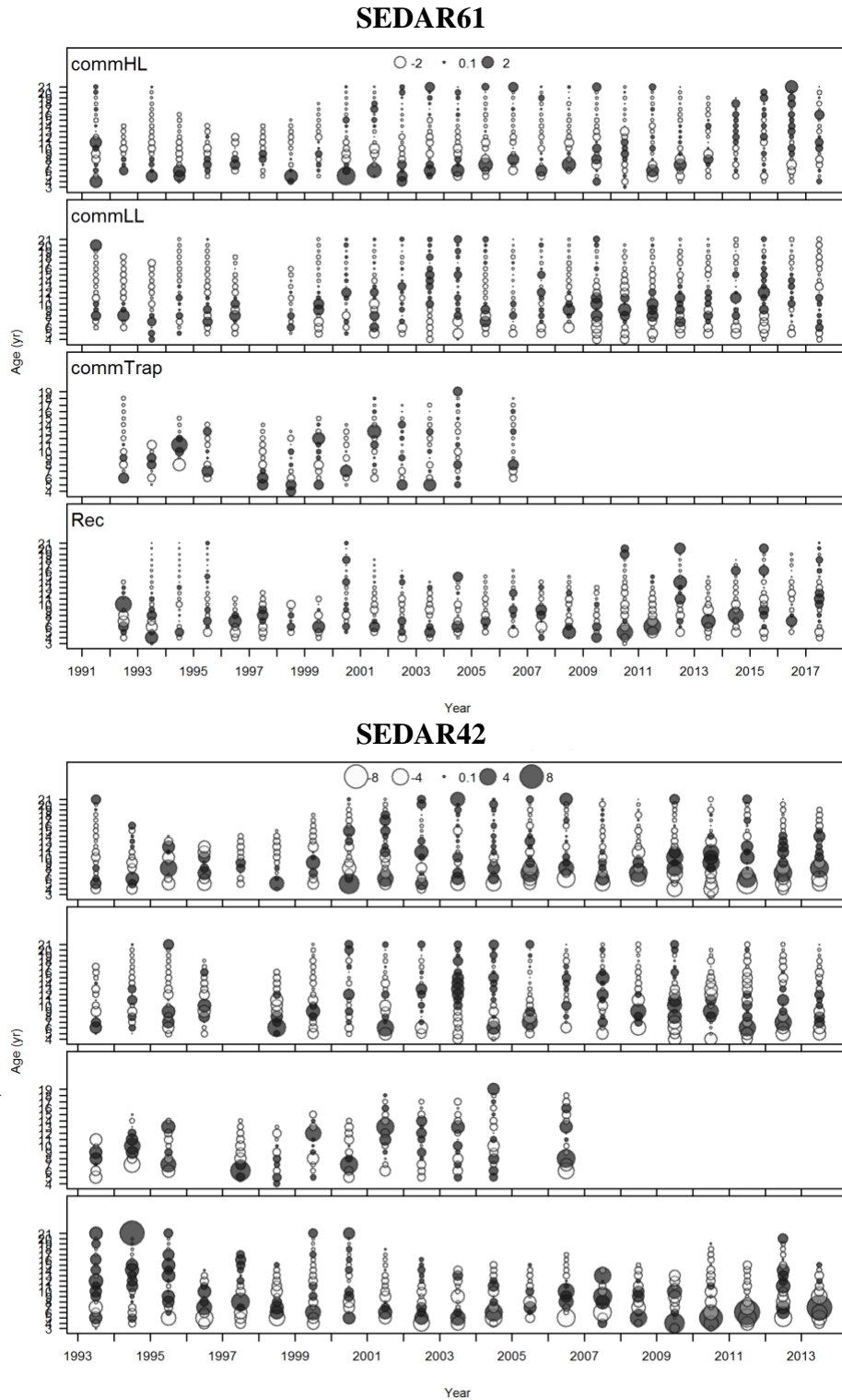


**Figure 4.26.** Model fits to the age composition of retained catch by the recreational fleet for Gulf of Mexico Red Grouper. Red lines represent predicted age compositions, while grey shaded regions represent observed age compositions. The effective sample size used to weight the yearly age composition data is provided by N adj for SEDAR61 (Upper Panel) and effN for SEDAR42 (Lower Panel) and shown in the upper right corner of each panel.

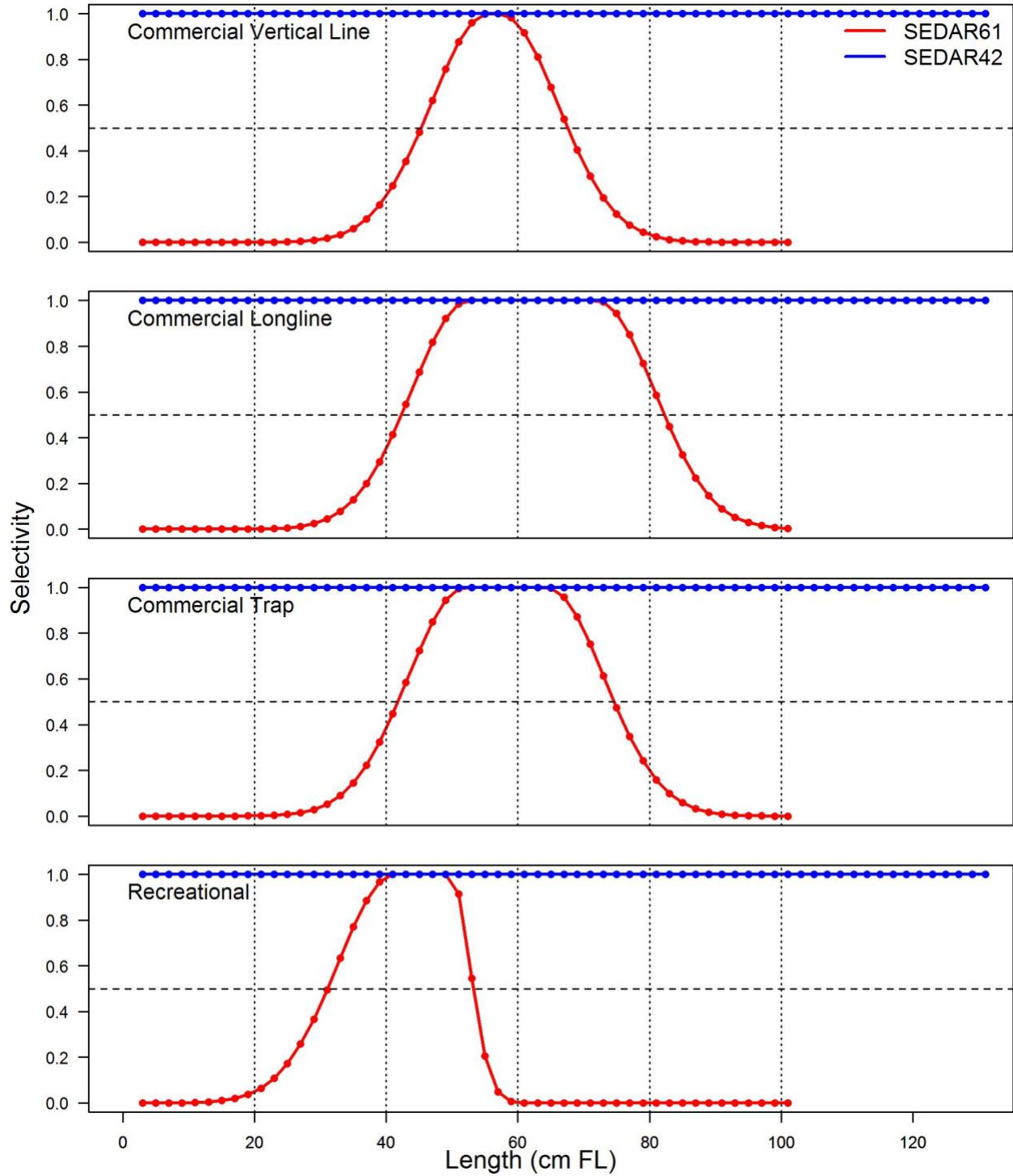


**Figure 4.26. Continued Model fits to the age composition of retained catch by the recreational fleet for Gulf of Mexico Red Grouper.**

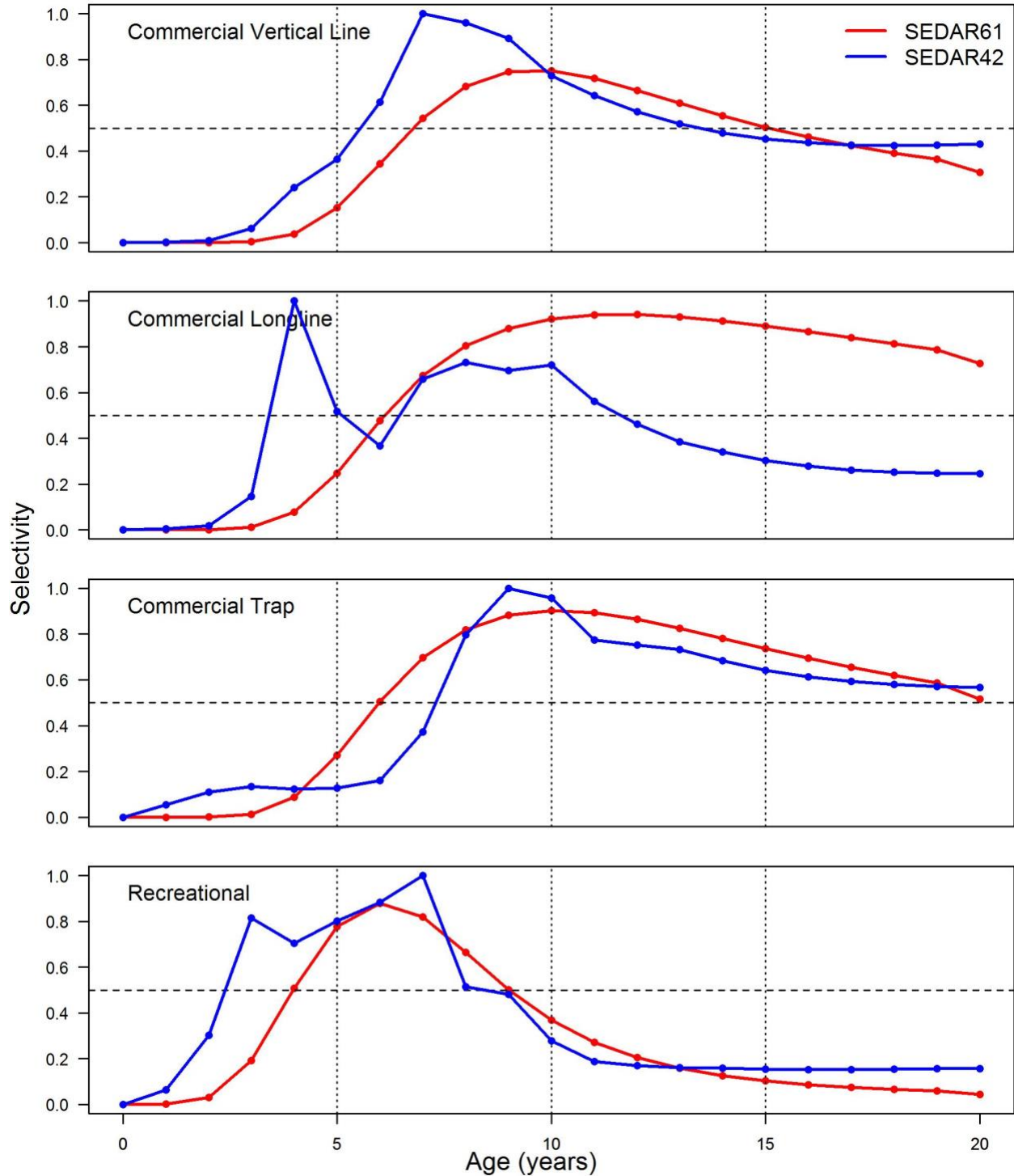




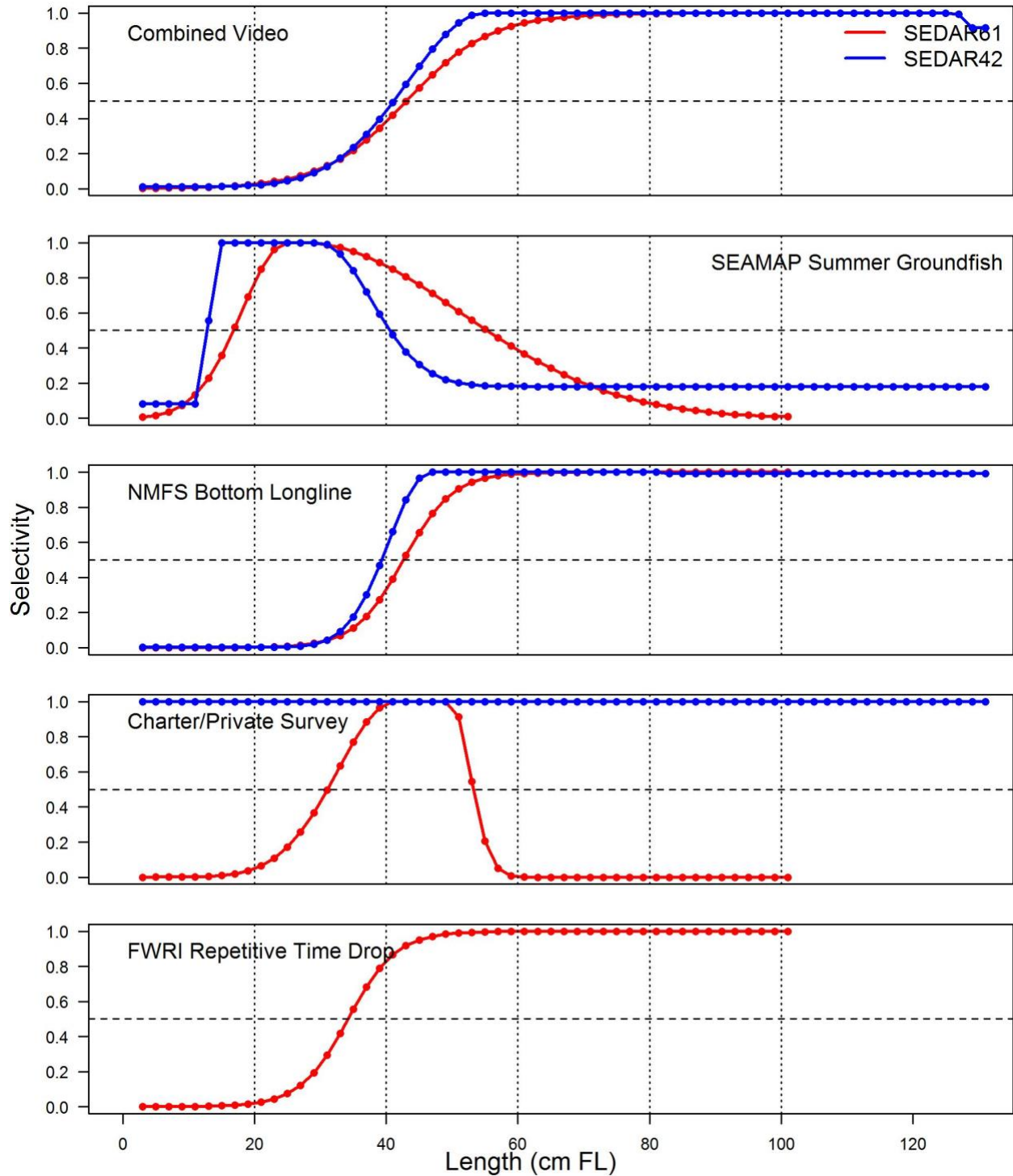
**Figure 4.27.** Pearson residuals for age composition data by year compared across fleets for Gulf of Mexico Red Grouper. Closed bubbles are positive residuals (observed > expected) and open bubbles are negative residuals (observed < expected). Results for SEDAR61 are in the Upper Panel and SEDAR42 results are in the Lower Panel.



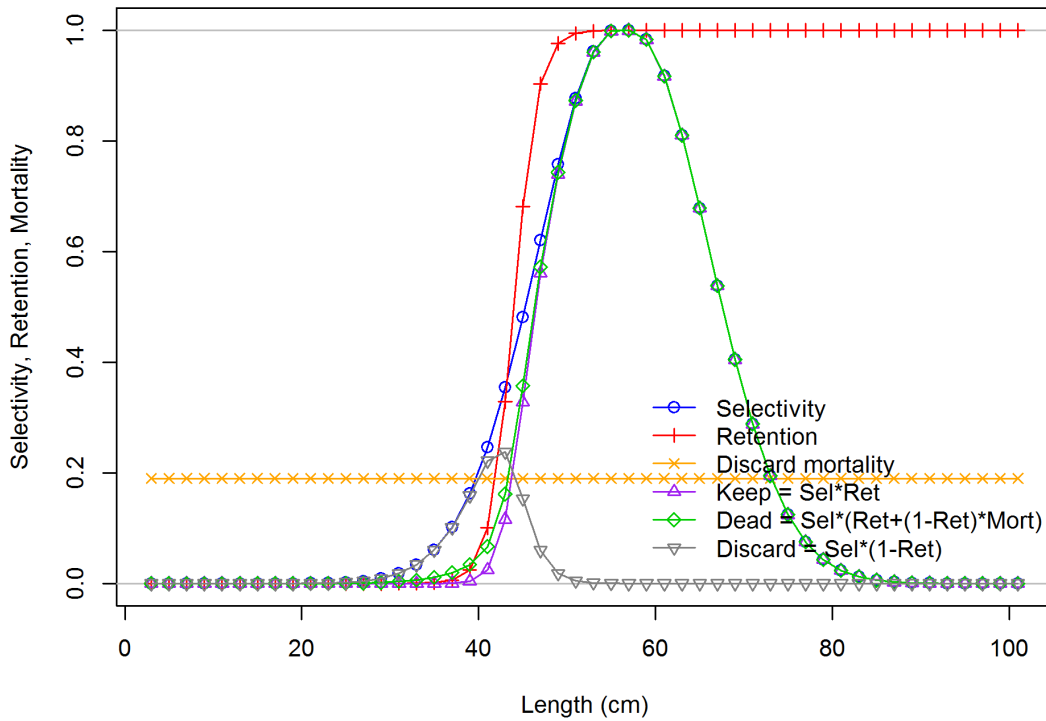
**Figure 4.28.** Terminal year (2017) length-based selectivity for each fleet for Gulf of Mexico Red Grouper. Dashed horizontal line indicates 50%, whereas the dashed vertical lines identify lengths in 20 cm FL intervals starting at 20 cm FL. Note that SEDAR42 set selectivity = 1 for all sizes.



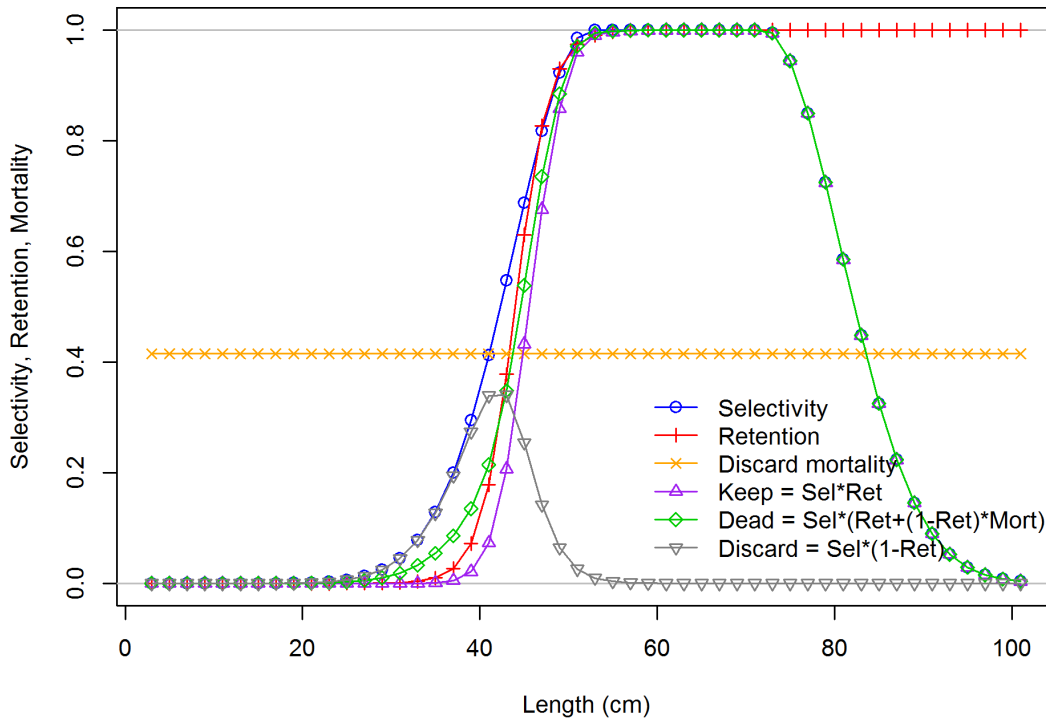
**Figure 4.29.** Terminal year (2017; 2006 for commercial trap) derived age-based selectivity for each fleet for Gulf of Mexico Red Grouper. Dashed horizontal line indicates 50%, whereas the dashed vertical lines identify ages of 5, 10, and 15 years.



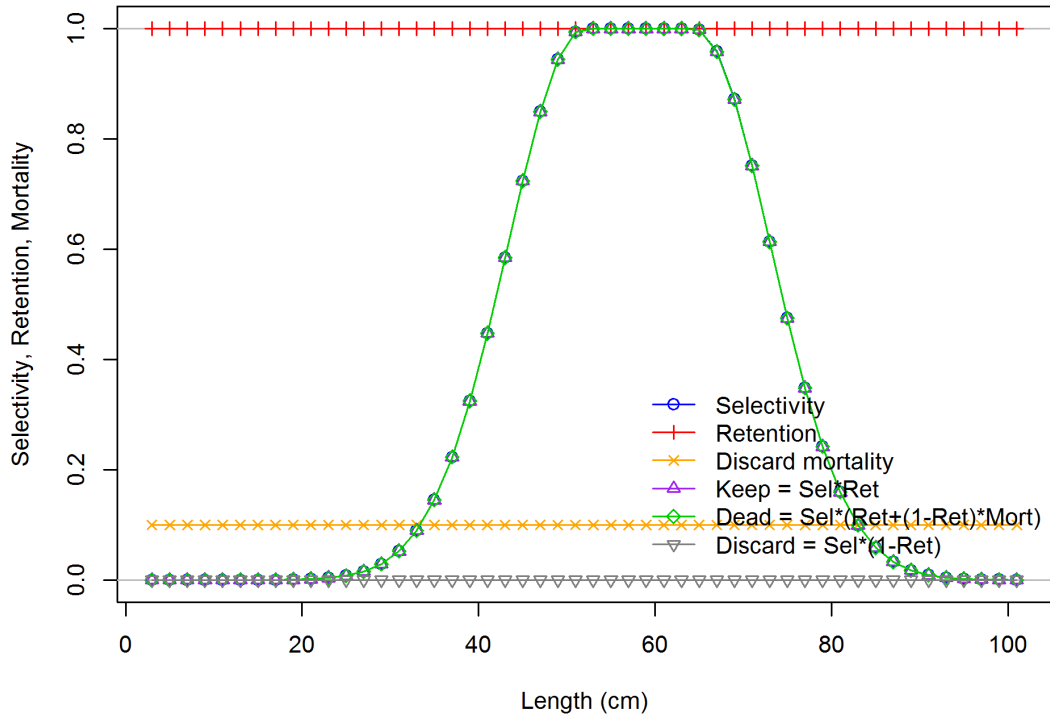
**Figure 4.30.** Terminal year (2017) length-based selectivity for each survey for Gulf of Mexico Red Grouper. Dashed horizontal line indicates 50%, whereas the dashed vertical lines identify lengths in 20 cm FL intervals starting at 20 cm FL.



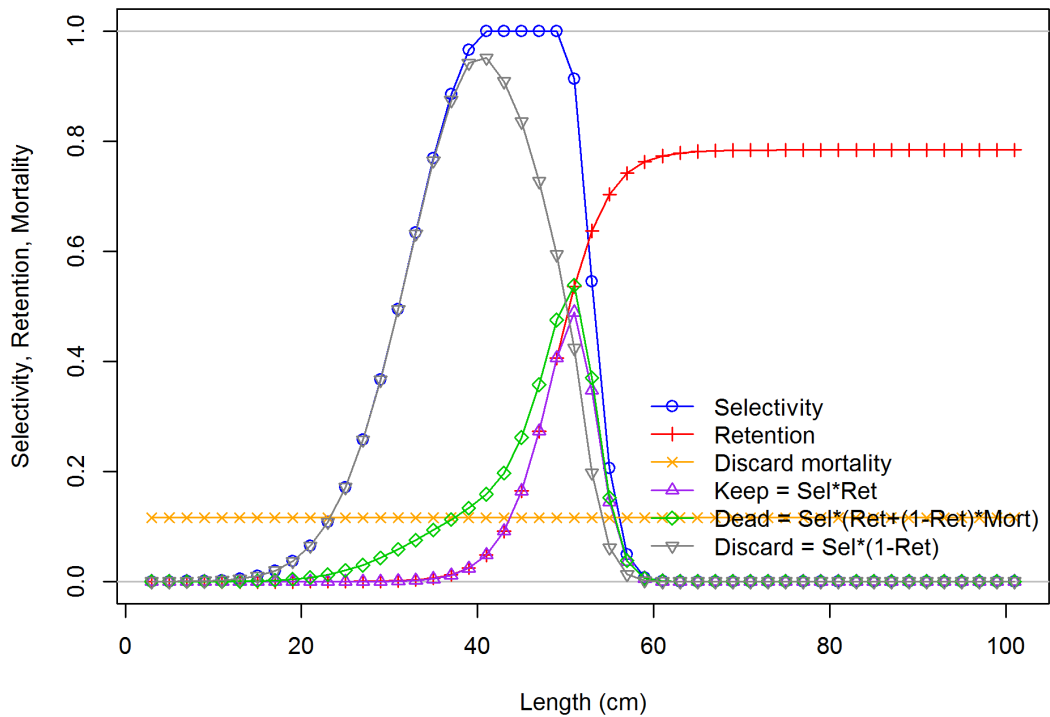
**Figure 4.31.** Terminal-year commercial vertical line fleet selectivity, retention, and discard mortality pattern.



**Figure 4.32.** Terminal-year commercial longline fleet selectivity, retention, and discard mortality pattern.

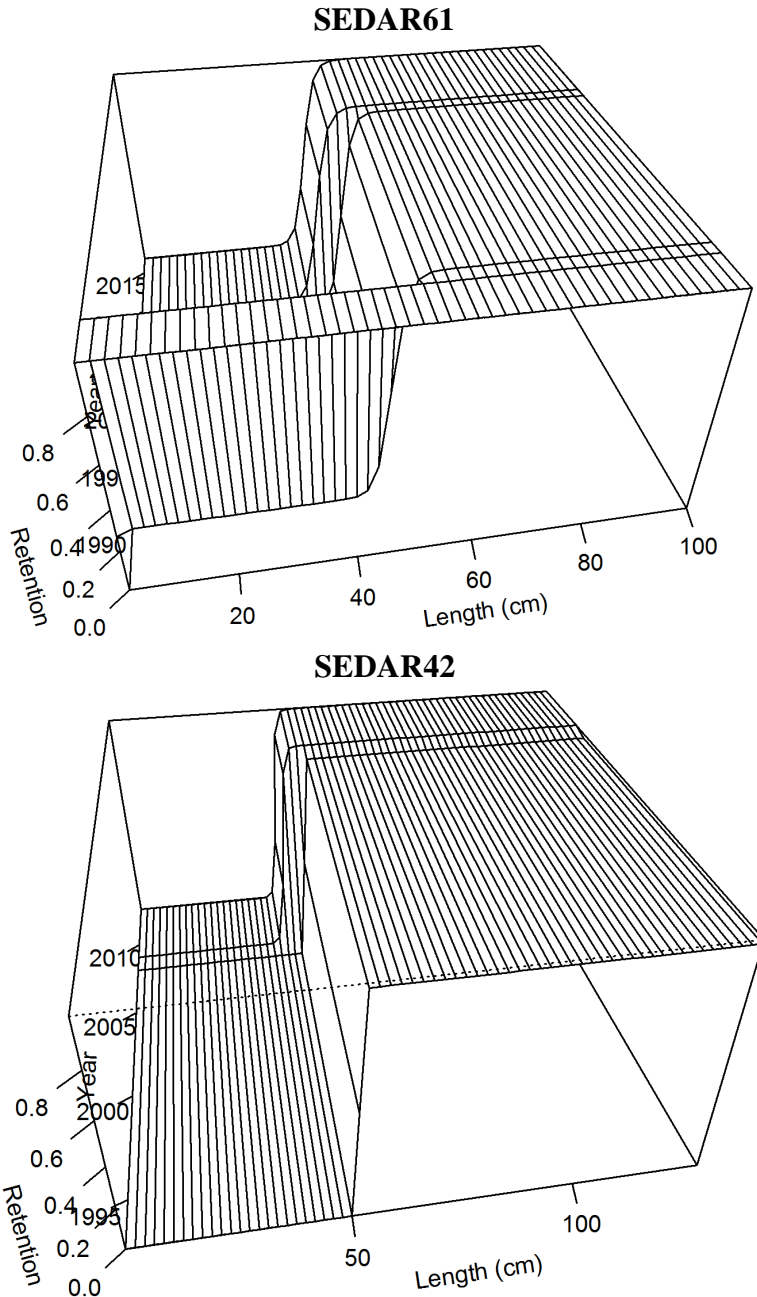


**Figure 4.33.** Terminal-year commercial trap fleet selectivity, retention, and discard mortality pattern.

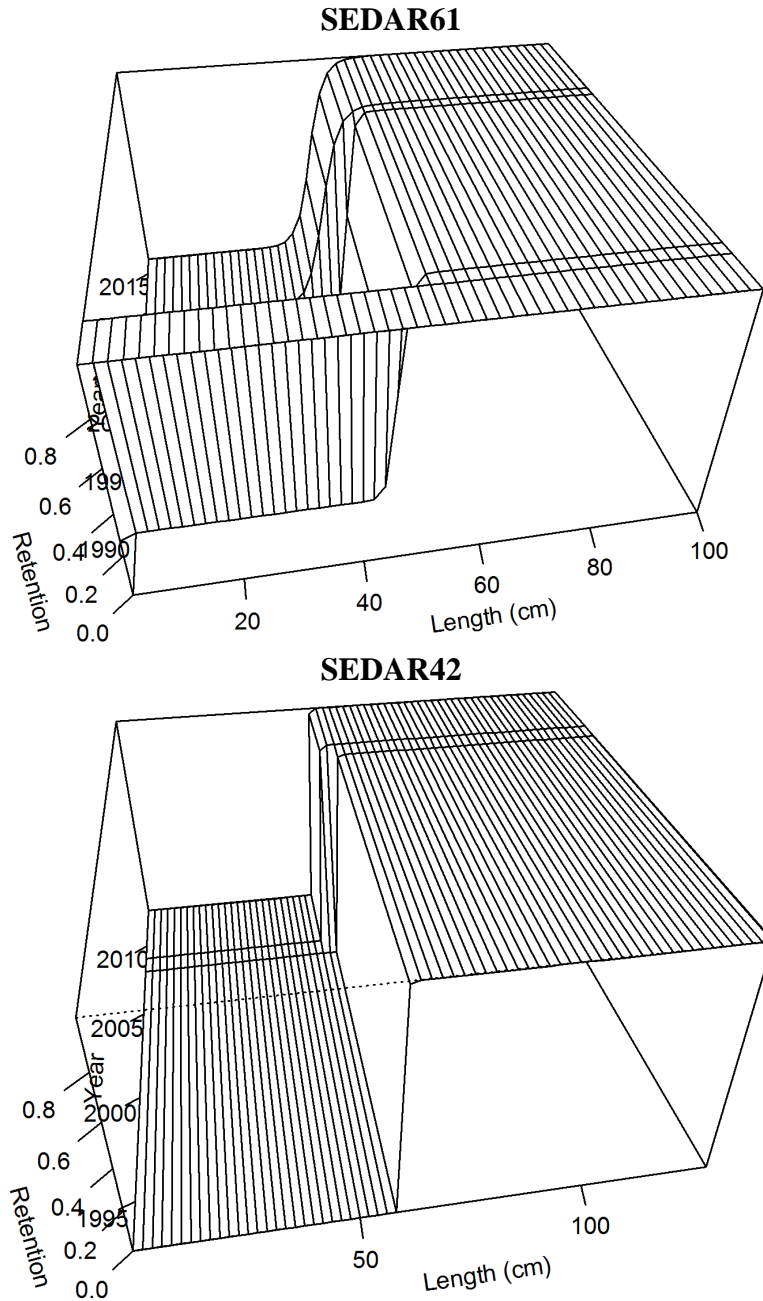


**Figure 4.34.** Terminal-year recreational fleet selectivity, retention, and discard mortality pattern.



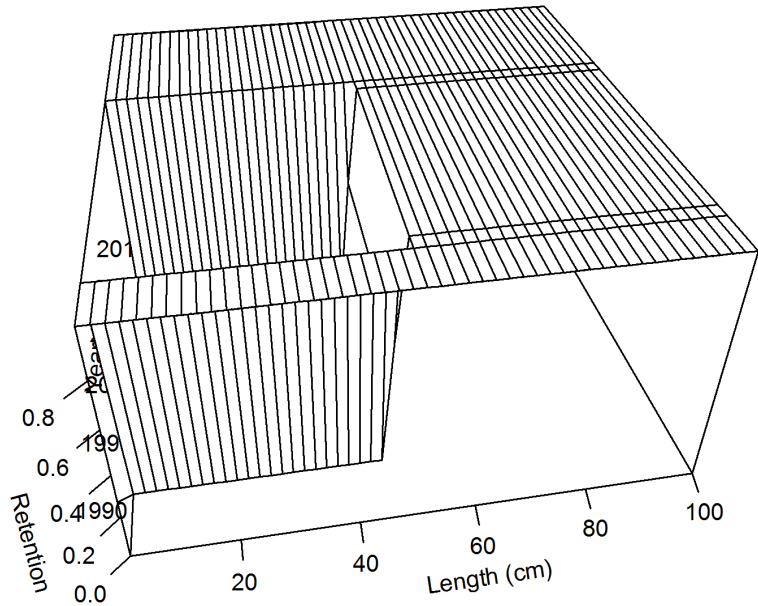


**Figure 4.35.** Time-varying retention at length for the commercial vertical line fishery for Gulf of Mexico Red Grouper. The changes were implemented to account for various minimum size limits, with pre-1990 retention fixed at full retention (i.e., no discarding). The width of the retention function is the only estimated parameter and is estimated for the most recent time block (2009-2017). Fixed parameters include the inflection point, which is fixed at each respective time period’s size limit, and the asymptote, which is fixed at the maximum value, under the assumption that fish caught above the size limit are retained. The width of the retention function for the earlier time period was fixed at the estimated value (1.157,  $CV = 0.23$ ) to improve model stability. The SEDAR61 estimates are provided in the Upper Panel and the SEDAR42 estimates are provided in the Lower Panel.

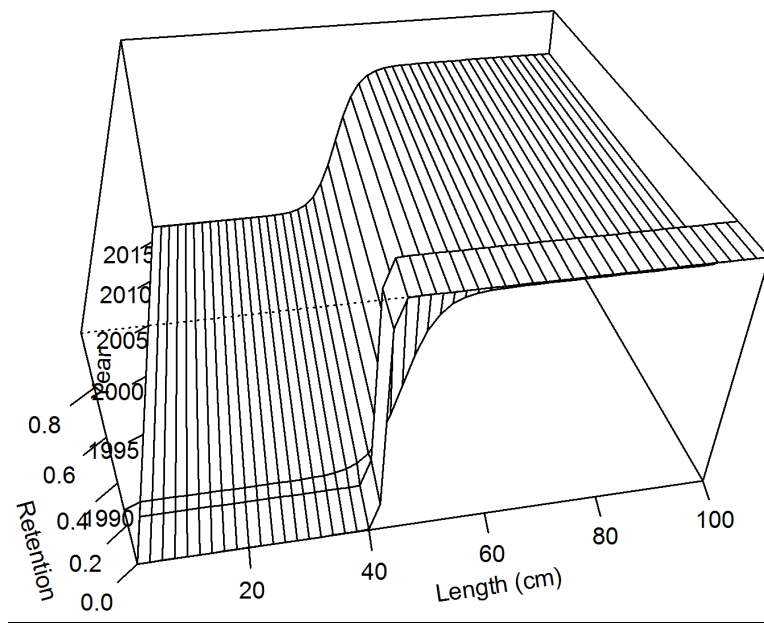


**Figure 4.36.** Time-varying retention at length for the commercial longline fishery for Gulf of Mexico Red Grouper. The changes were implemented to account for various minimum size limits, with pre-1990 retention fixed at full retention (i.e., no discarding). The width of the retention function is the only estimated parameter and is estimated for time blocks 1990-2008 and 2009-2017. Fixed parameters include the inflection point, which is fixed at each respective time period’s size limit, and the asymptote, which is fixed at the maximum value, under the assumption that fish caught above the size limit are retained. The SEDAR61 estimates are provided in the Upper Panel and the SEDAR42 estimates are provided in the Lower Panel.

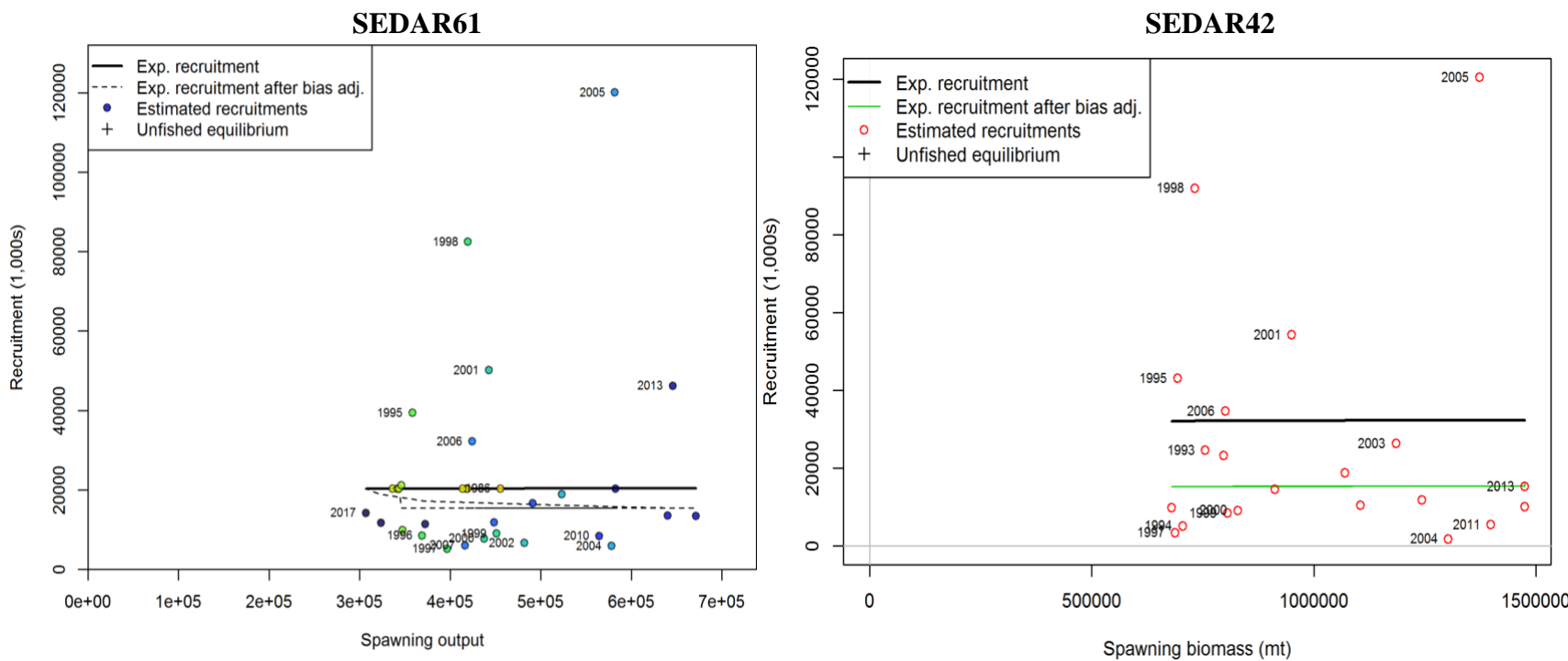




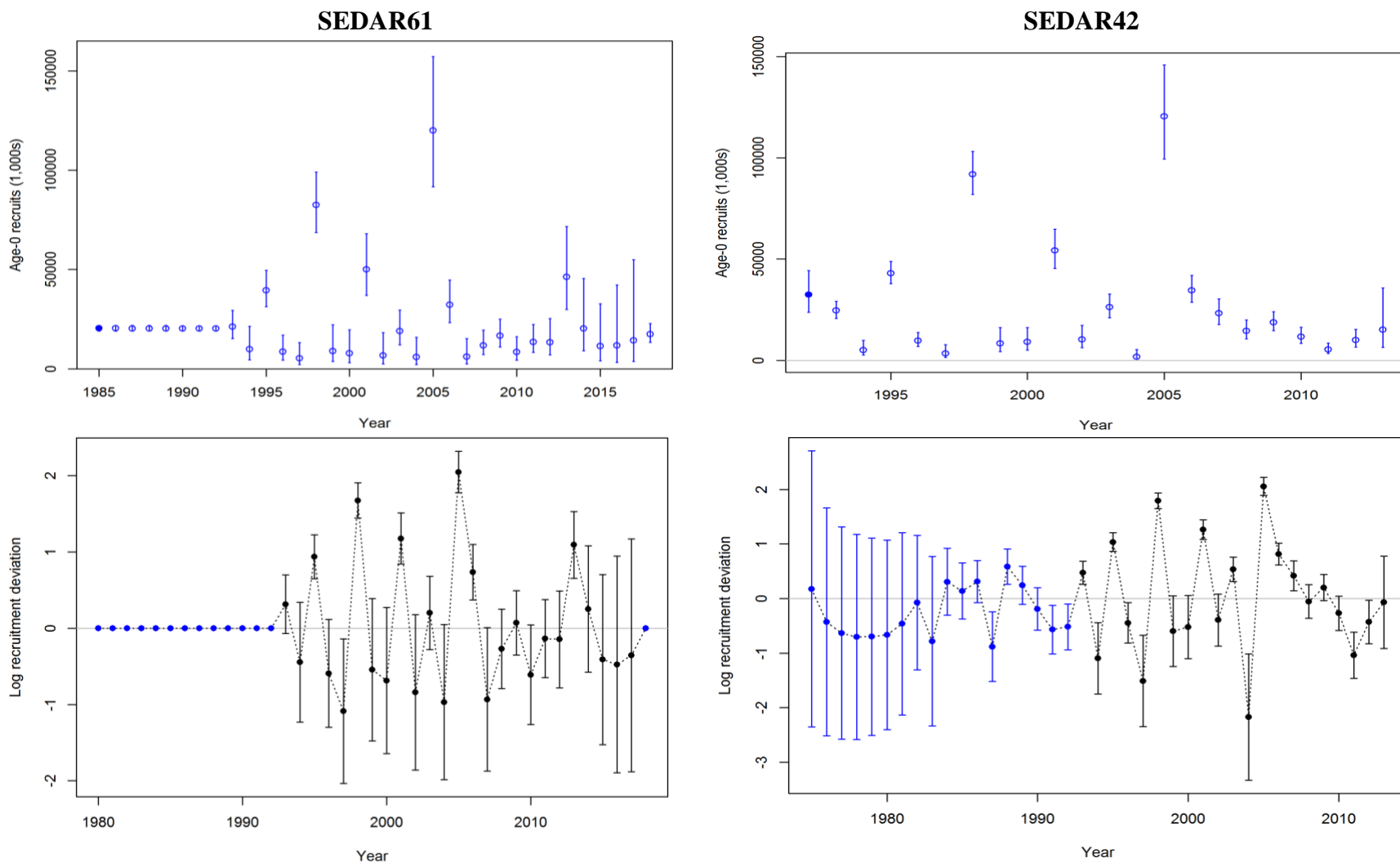
**Figure 4.37.** Time-varying retention at length for the commercial trap fishery for Gulf of Mexico Red Grouper. The changes were implemented to account for a minimum size limit, with pre-1990 retention fixed at full retention (i.e., no discarding). Fixed parameters include the inflection point, which is fixed at the size limit, the width of the inflection and the asymptote. The SEDAR61 estimates are provided, no time-varying retention was present in the SEDAR42 Final Model.



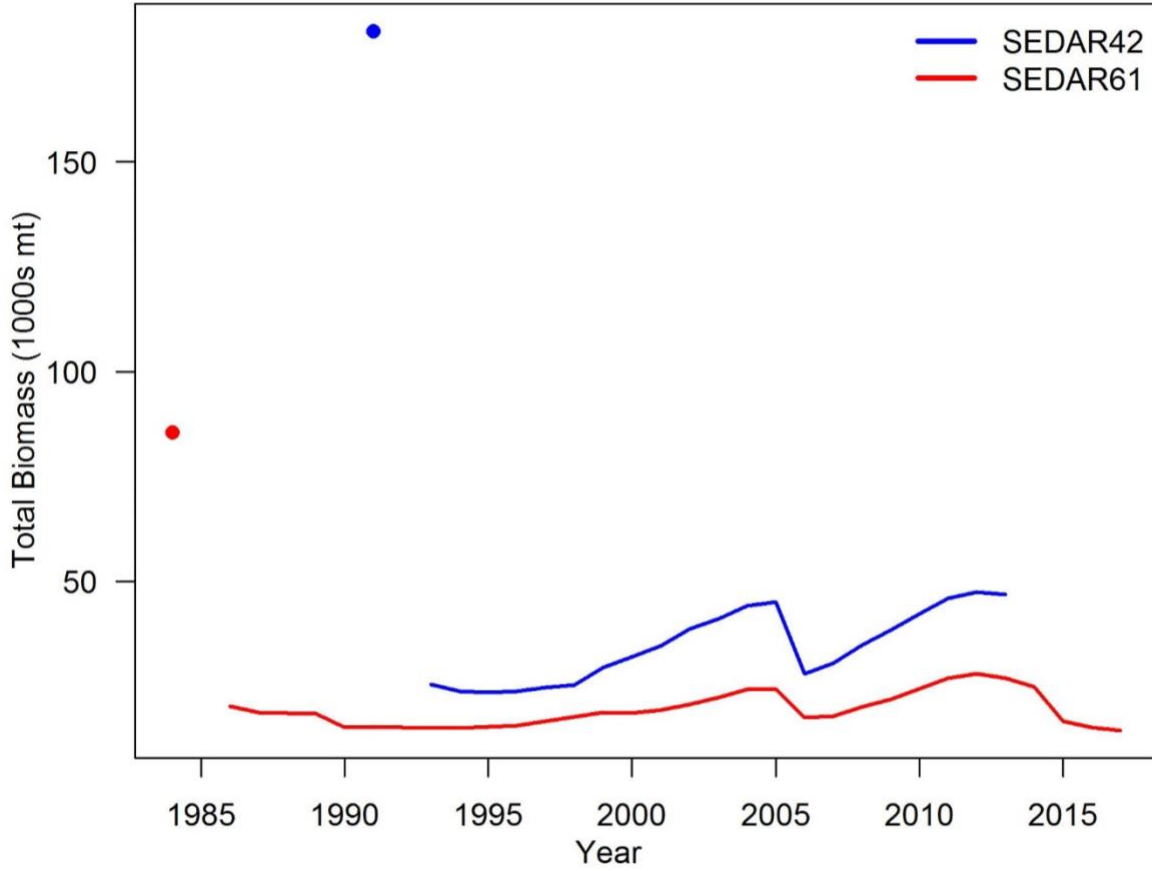
**Figure 4.38.** Time-varying retention at length for the recreational fishery for Gulf of Mexico Red Grouper. The changes were implemented to account for various minimum size limits. The asymptote of the retention function in the 1990-2017 time period is the only estimated parameter to allow for less than 100% retention due to bag limits and quota restrictions. Fixed parameters include the inflection point, which is fixed at each respective time period's size limit, and the width of the retention function which was fixed at 0.5 in the 1986-1989 time block and at the estimated value (2.865, CV= 0.101) in the 1990-2017 time block to improve model stability. The SEDAR61 estimates are provided, no time-varying retention was present in the SEDAR42 Final Model.



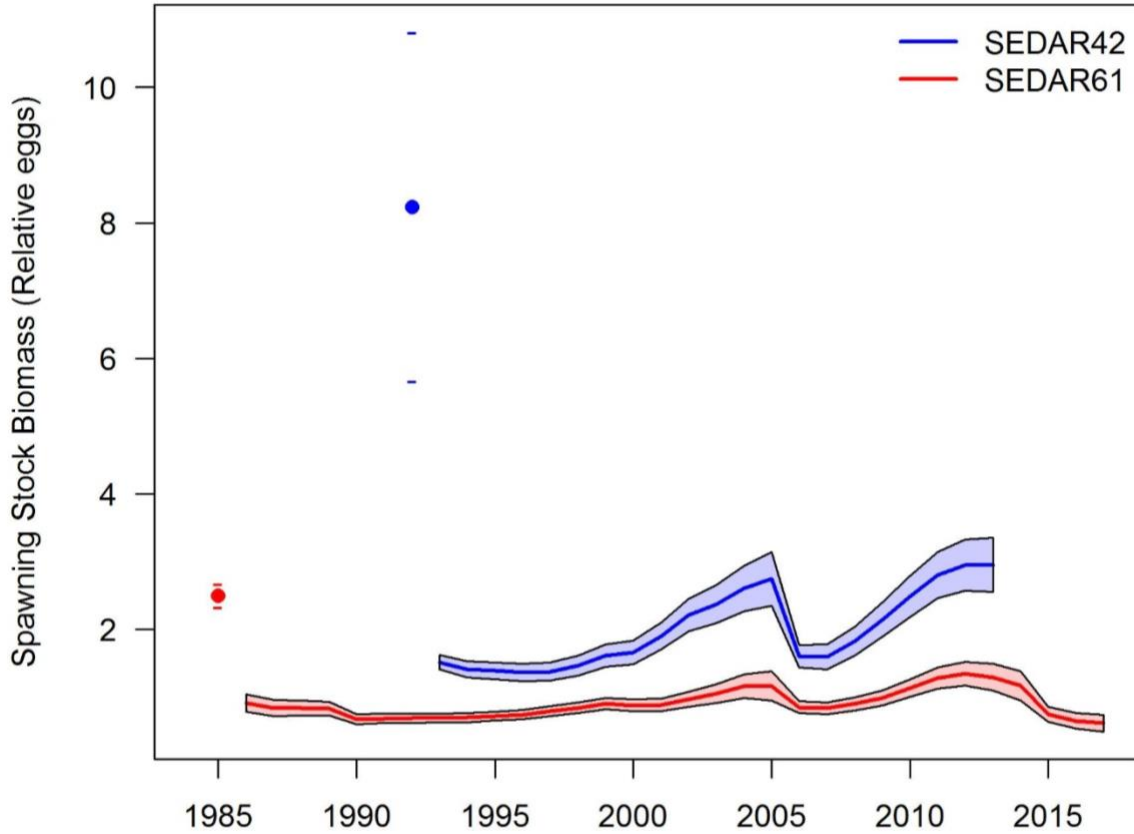
**Figure 4.39.** Predicted stock-recruitment relationship for Gulf of Mexico Red Grouper (steepness = 0.99, *SigmaR* estimated at 0.815). Plotted are predicted annual recruitments from Stock Synthesis (circles) and expected recruitment from the stock recruit relationship (black line). Labels are included on the first year, last year, and years with natural log deviations > 0.5. Results from SEDAR61 are presented in the left panel and those from SEDAR42 are presented in the right panel.



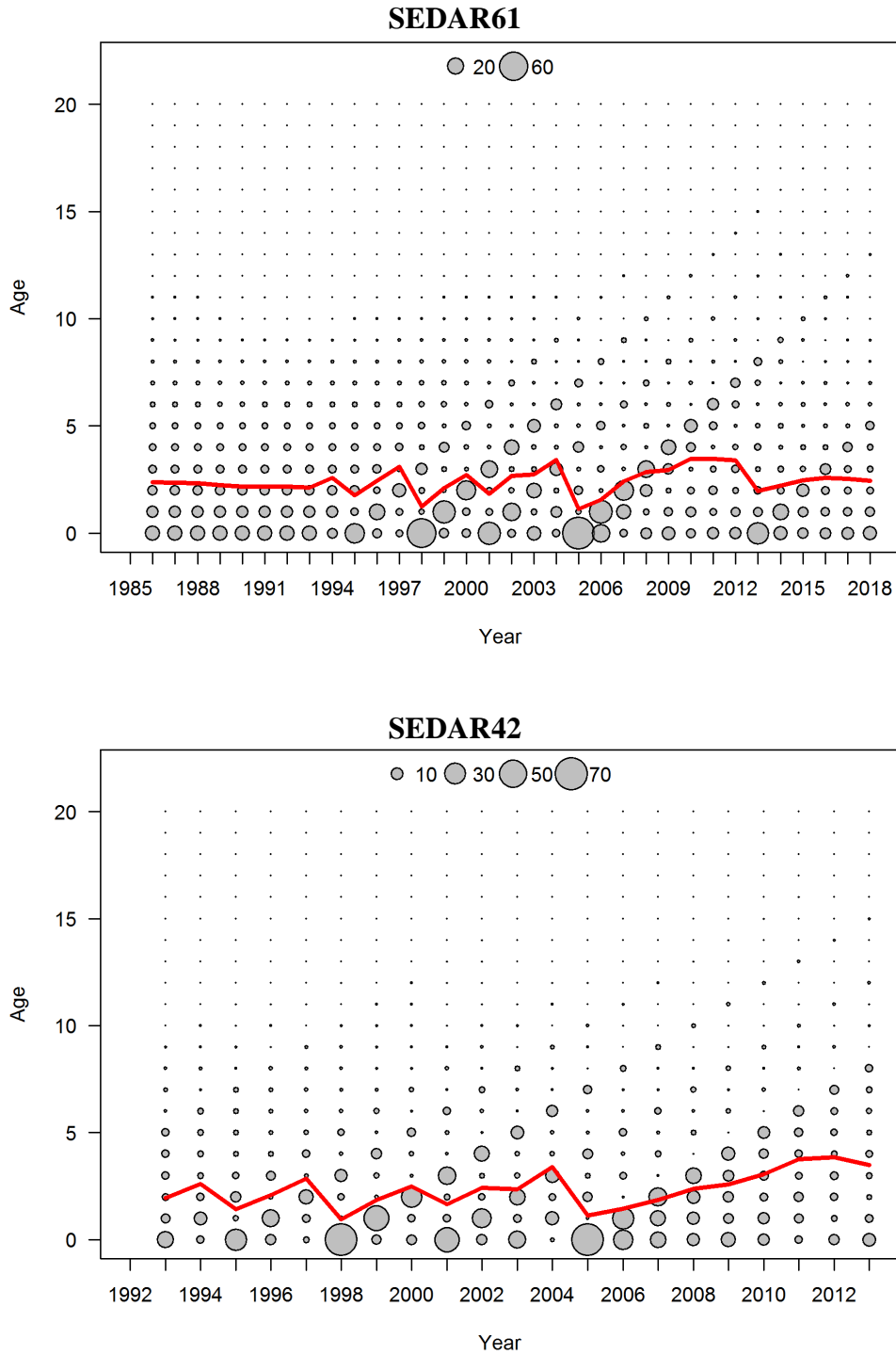
**Figure 4.40.** Estimated Age-0 recruitment with 95% confidence intervals and log recruitment deviations (1993-2017) for Gulf of Mexico Red Grouper (steepness = 0.99,  $\sigma_R$  estimated at 0.815). Results from SEDAR61 are presented in the left panels and those from SEDAR42 are presented in the right panels.



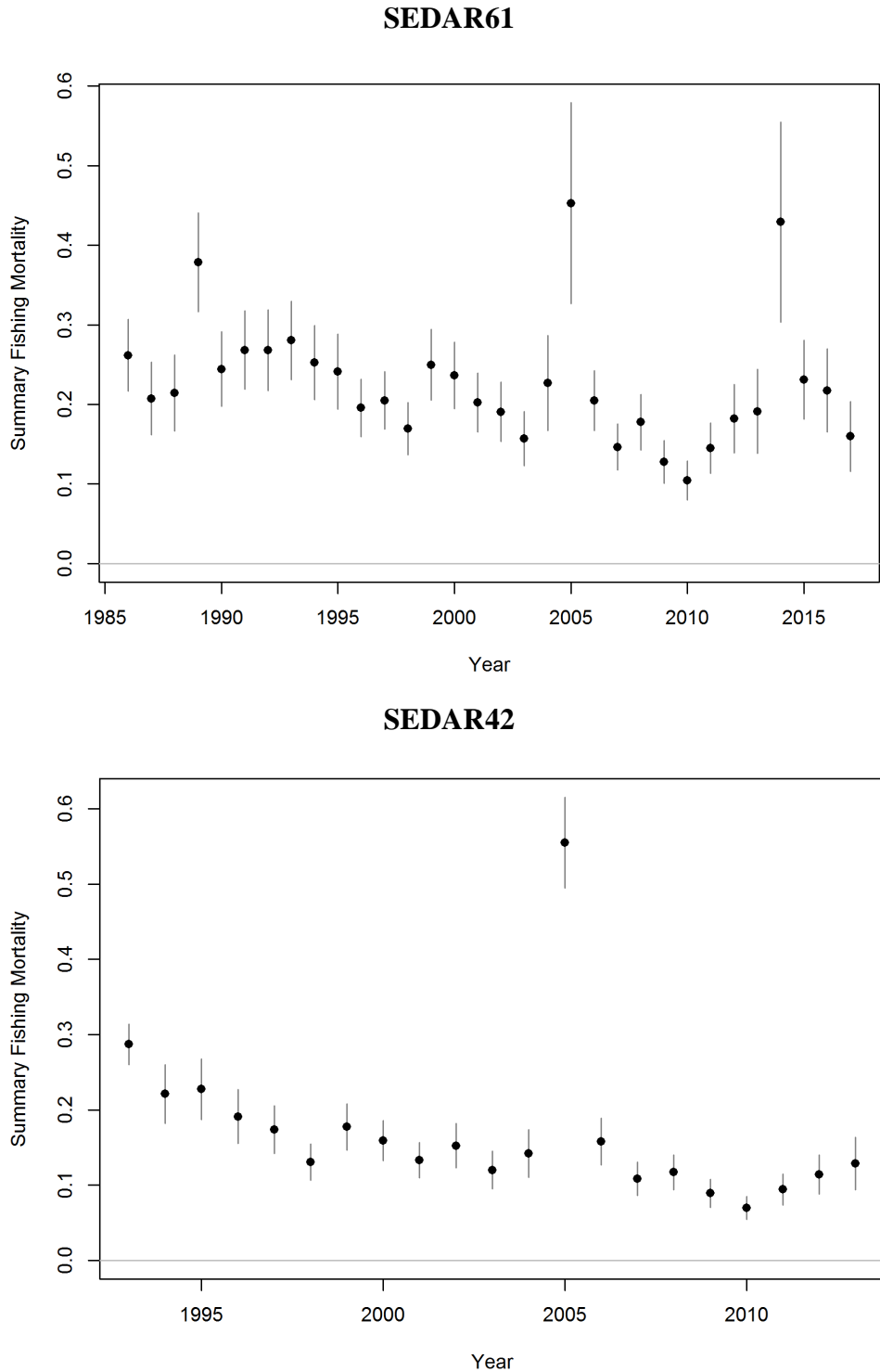
**Figure 4.41.** Estimates of total biomass (in 1000s of metric tons) of Gulf of Mexico Red Grouper. The solid circle is the estimated unfished equilibrium biomass.



**Figure 4.42.** Estimates of spawning stock biomass (relative number of eggs) for Gulf of Mexico Red Grouper. The solid circle is the estimated unfished spawning stock biomass. Shaded region and dashed lines reflect the 95% confidence interval.



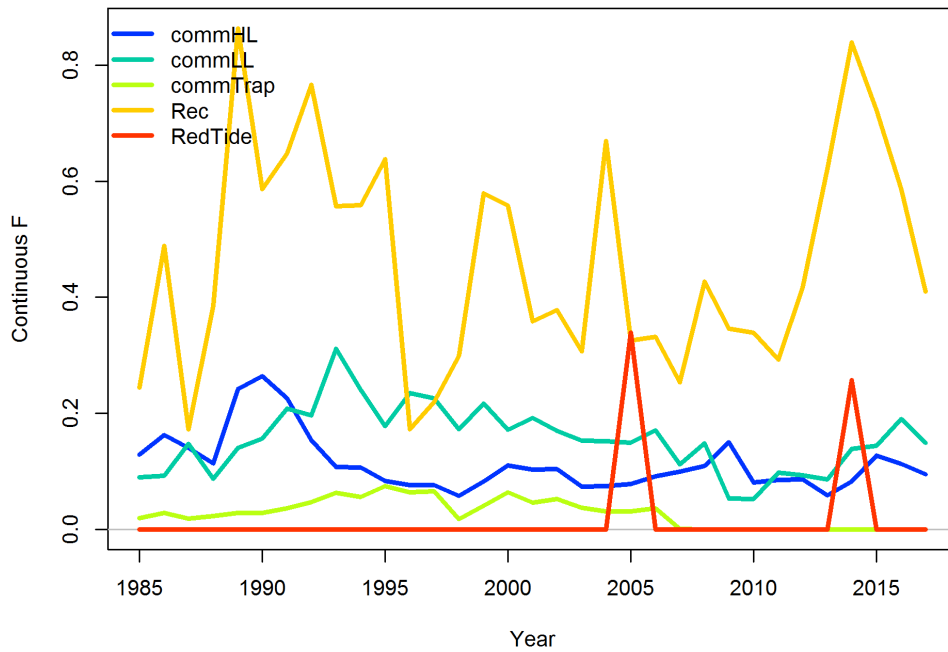
**Figure 4.43.** Mid-year age composition (open bubbles) and mean age (based on average estimated abundance; red line) of Gulf of Mexico Red Grouper. Results from SEDAR61 are presented in the Upper Panel and those from the SEDAR42 are presented in the Lower Panel.



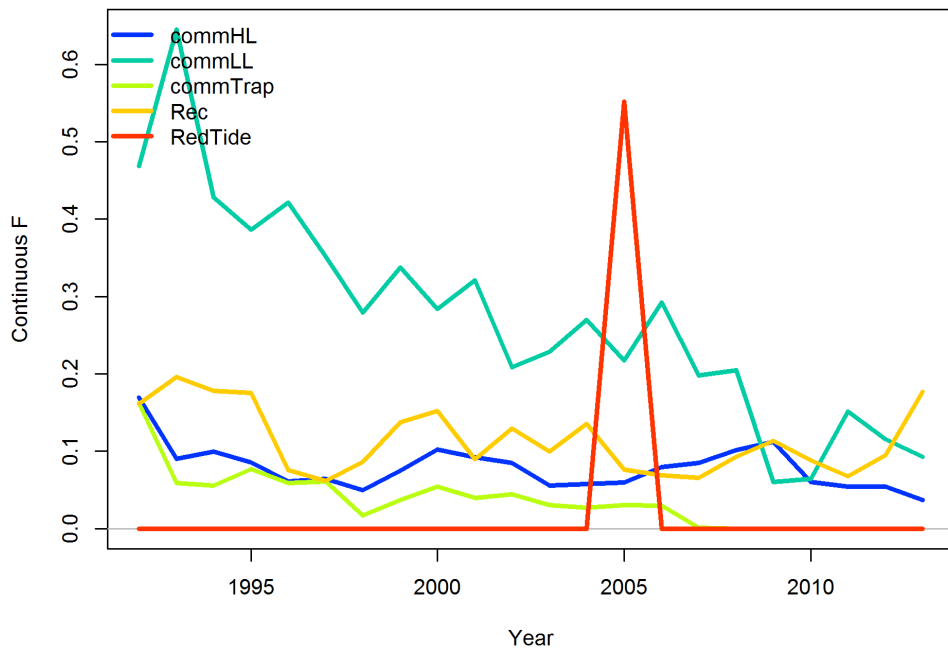
**Figure 4.44.** Annual exploitation rate (total kill/total biomass) for Gulf of Mexico Red Grouper with 95% confidence intervals for SEDAR61 (Upper Panel) and SEDAR42 (Lower Panel). Note that values in 2005 and 2014 include red tide mortality [SEDAR61 2005 without red tide M = 0.158; 2014 without red tide M = 0.216].



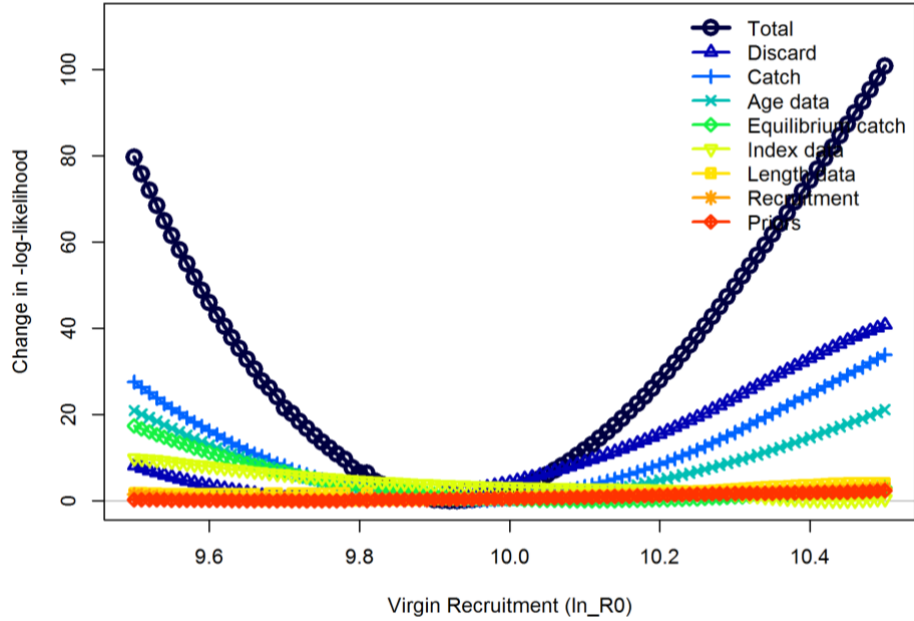
**SEDAR61**



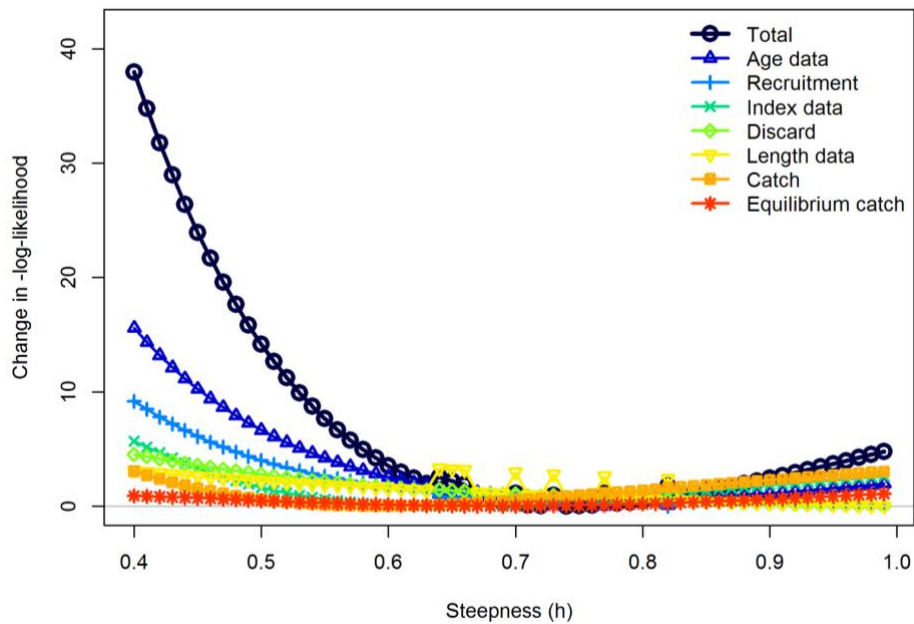
**SEDAR42**



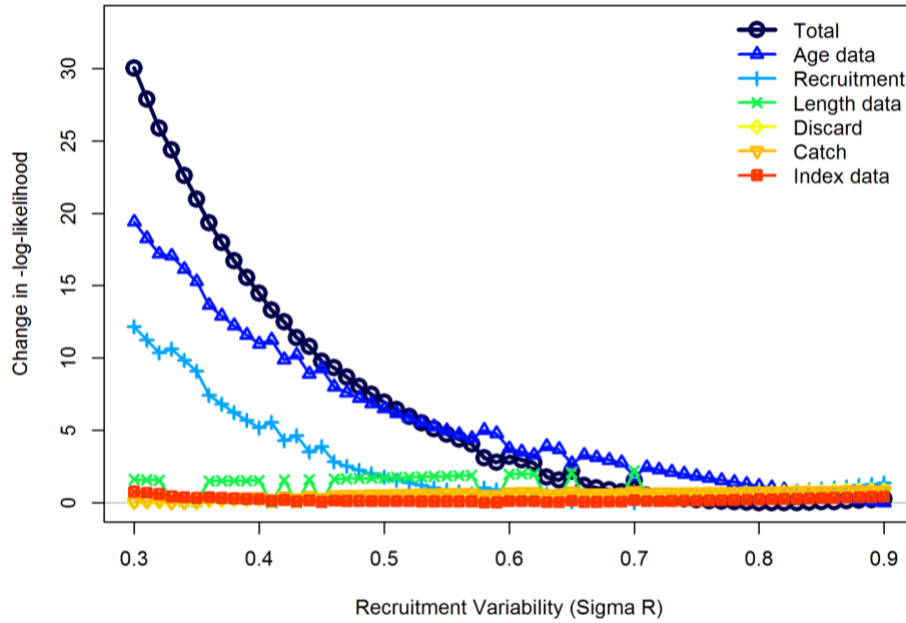
**Figure 4.45.** Fleet-specific apical fishing mortality rates for Gulf of Mexico Red Grouper for SEDAR61 (Upper Panel) and SEDAR42 (Lower Panel). This represents the instantaneous fishing mortality level on the most vulnerable age class for each fleet.



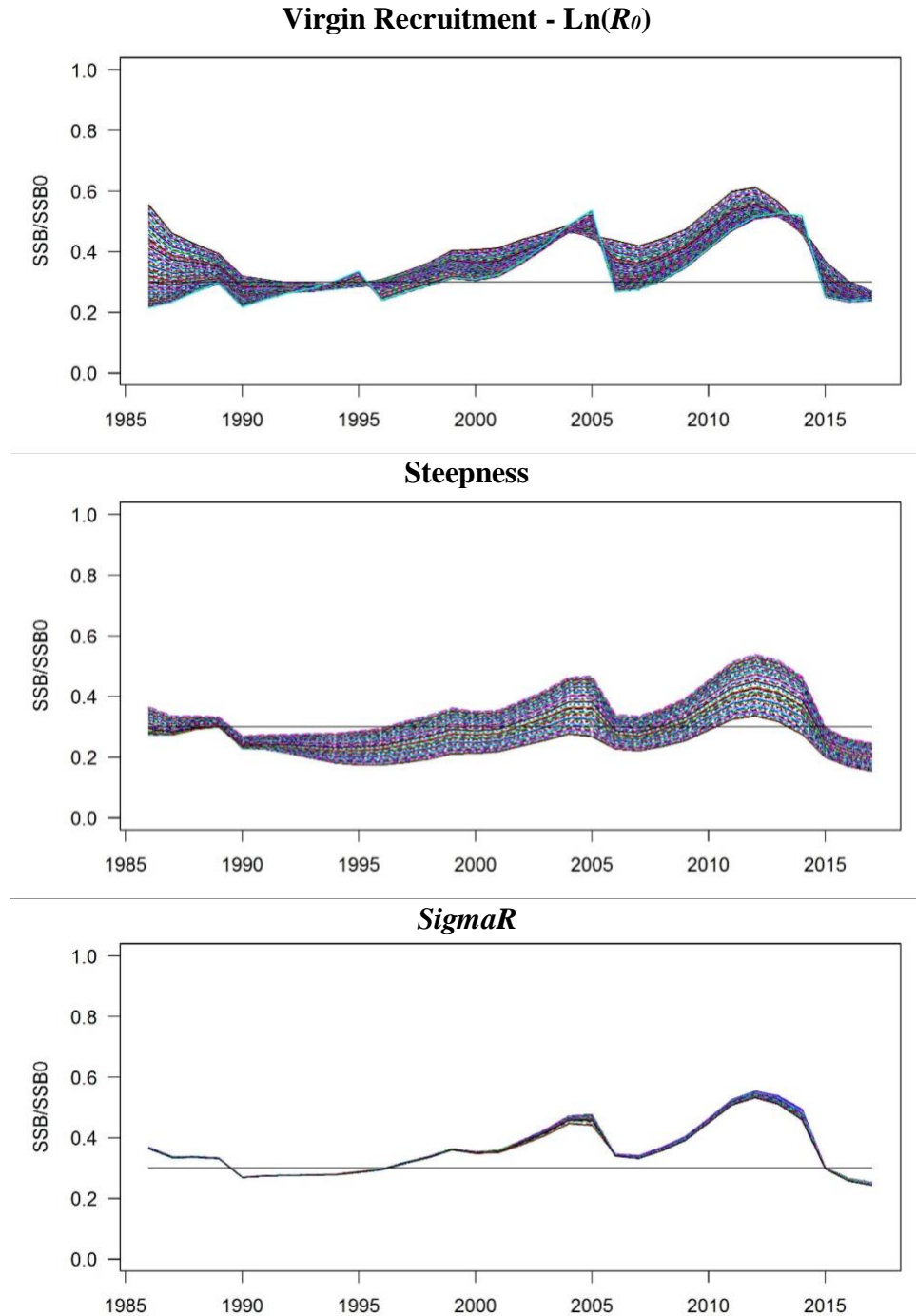
**Figure 4.46.** The profile likelihood for the virgin recruitment parameter of the Beverton – Holt stock-recruit function for Gulf of Mexico Red Grouper. Each line represents the change in negative log-likelihood value for each of the data sources fit in the model across the range of fixed virgin recruitment values tested in the profile diagnostic run.



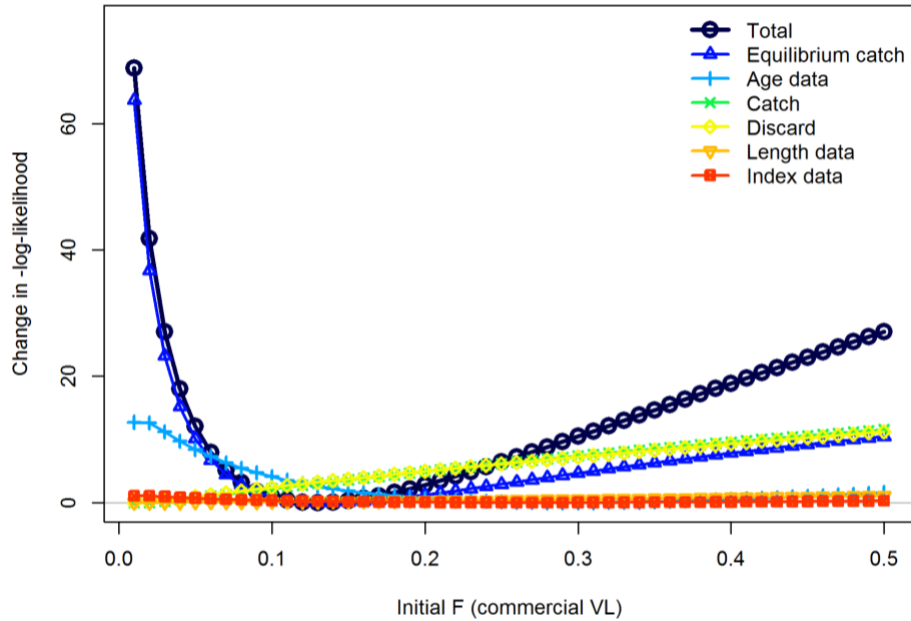
**Figure 4.47.** The profile likelihood for the steepness parameter of the Beverton – Holt stock-recruit function for Gulf of Mexico Red Grouper. Each line represents the change in negative log-likelihood value for each of the data sources fit in the model across the range of fixed steepness values tested in the profile diagnostic run.



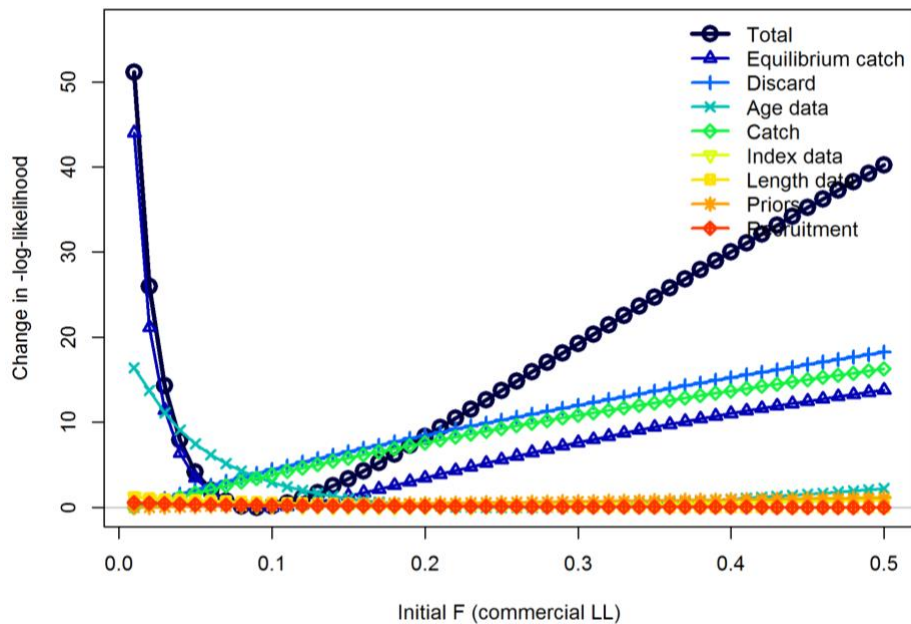
**Figure 4.48.** The profile likelihood for the variance parameter of the Beverton – Holt stock-recruit function for Gulf of Mexico Red Grouper. Each line represents the change in negative log-likelihood value for each of the data sources fit in the model across the range of fixed variance values tested in the profile diagnostic run.



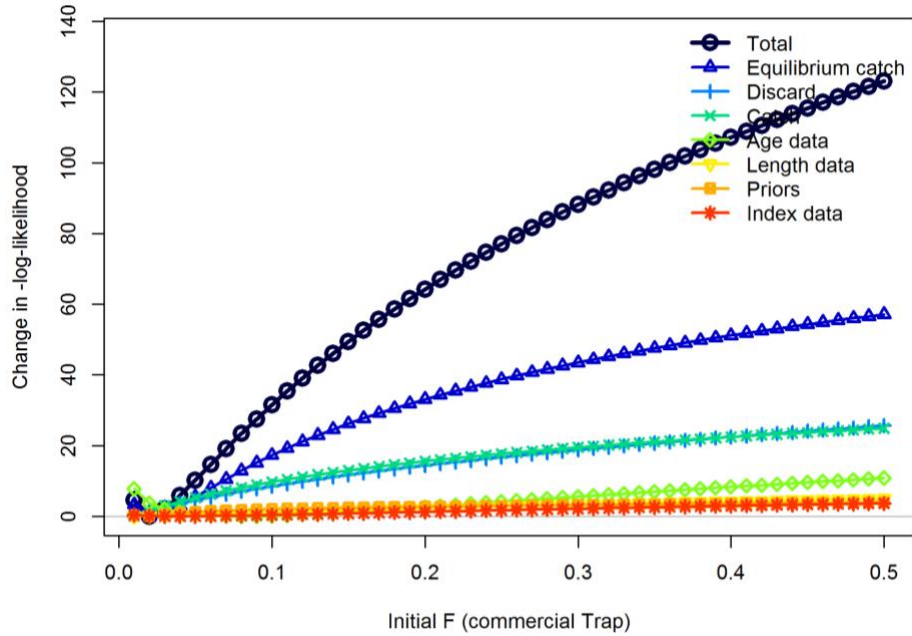
**Figure 4.49.** Trends in relative spawning stock biomass (SSB is in relative number of eggs) of Gulf of Mexico Red Grouper for each of the profile likelihood runs. The top panel represents the range of values for virgin recruitment ( $\ln(R_0)$ ), the middle panel represents the range of values for steepness, and the bottom panel represents the range of values for the stock-recruit variance term ( $\sigma_R$ ). Note that not all of the values of the parameters used in the profile likelihood analyses are realistic for Red Grouper.



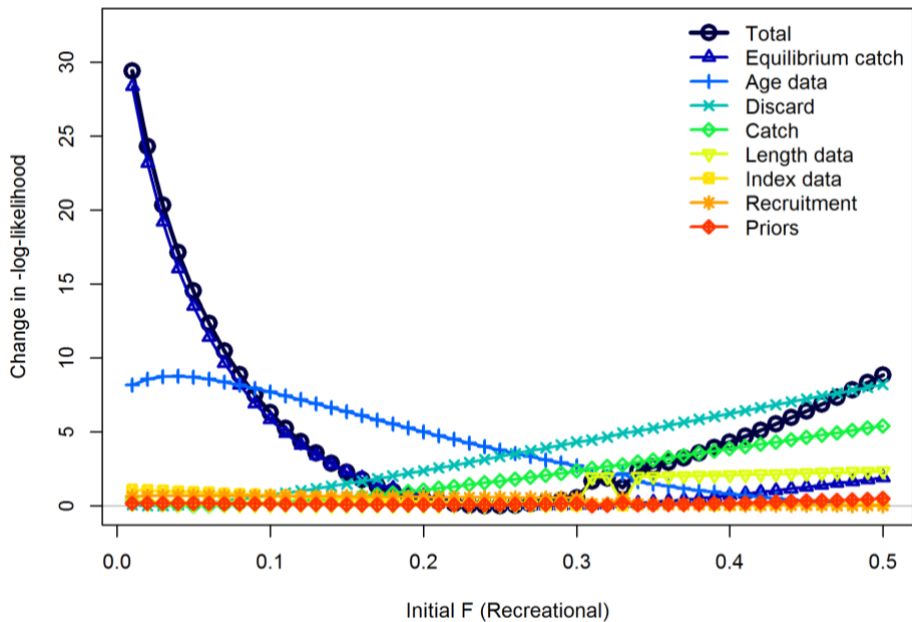
**Figure 4.50.** The profile likelihood for the initial fishing mortality rate for the commercial vertical line fleet for Gulf of Mexico Red Grouper. Each line represents the change in negative log-likelihood value for each of the data sources fit in the model across the range of fixed initial fishing mortality values tested in the profile diagnostic run.



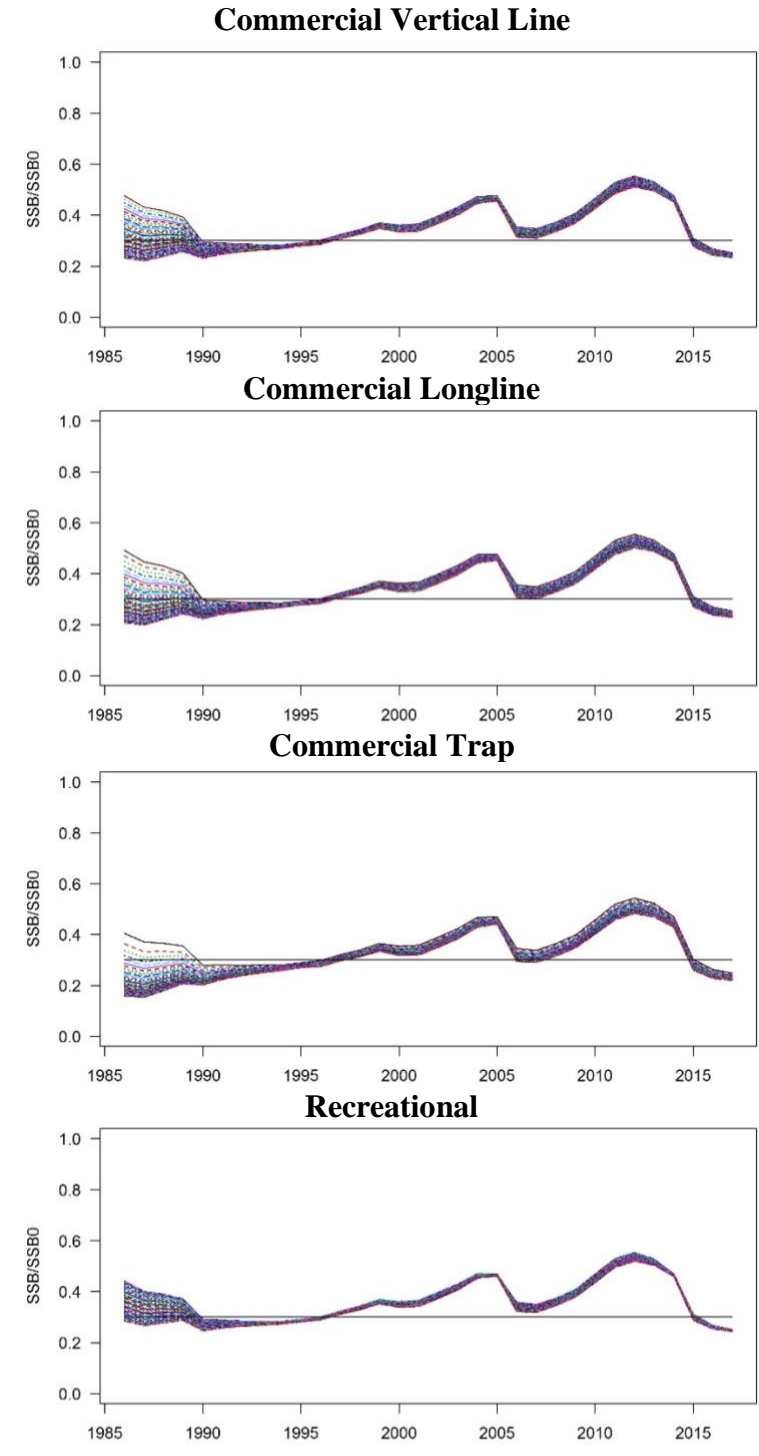
**Figure 4.51.** The profile likelihood for the initial fishing mortality rate for the commercial longline fleet for Gulf of Mexico Red Grouper. Each line represents the change in negative log-likelihood value for each of the data sources fit in the model across the range of fixed initial fishing mortality values tested in the profile diagnostic run.



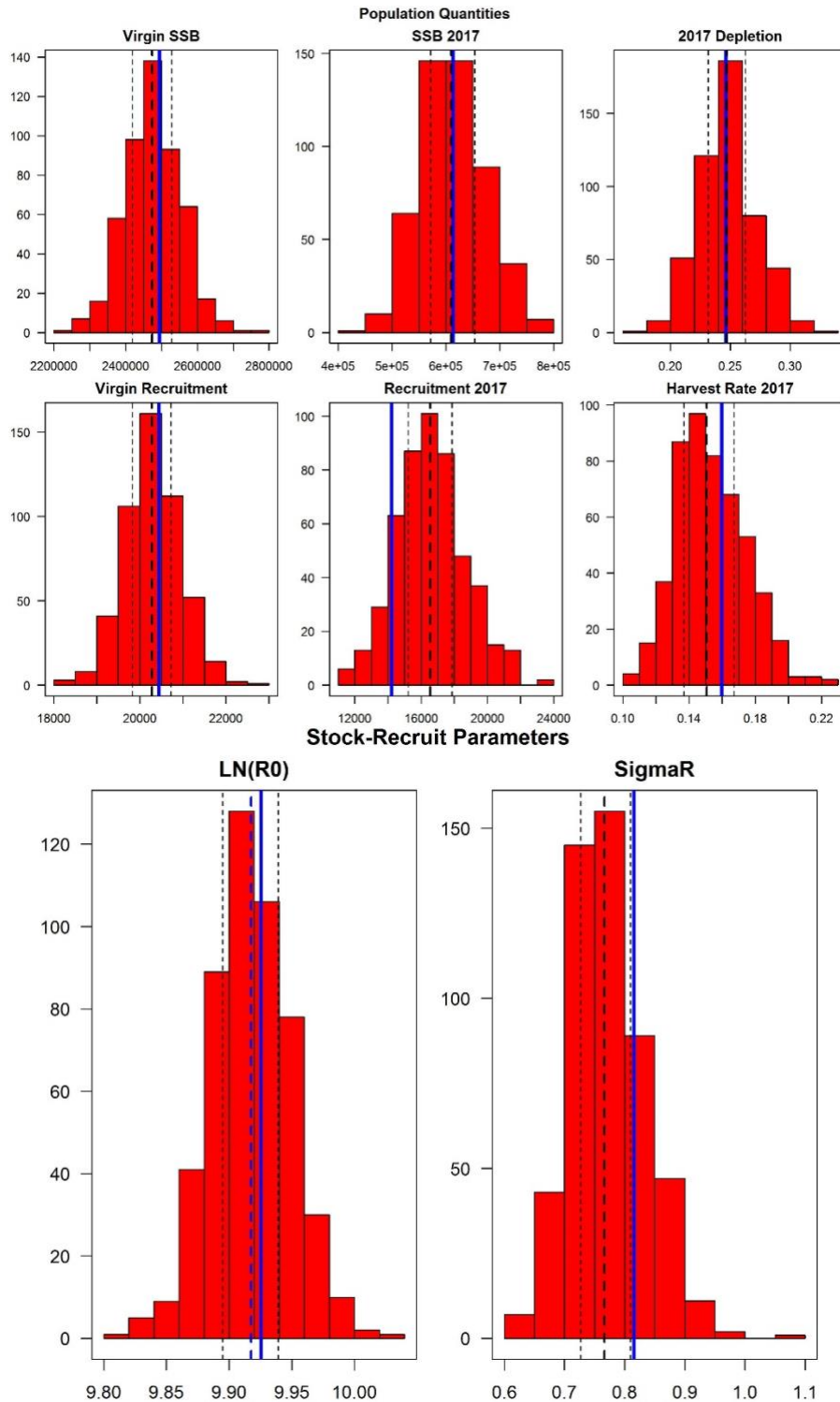
**Figure 4.52.** The profile likelihood for the initial fishing mortality rate for the commercial trap fleet for Gulf of Mexico Red Grouper. Each line represents the change in negative log-likelihood value for each of the data sources fit in the model across the range of fixed initial fishing mortality values tested in the profile diagnostic run.



**Figure 4.53.** The profile likelihood for the initial fishing mortality rate for the recreational fleet for Gulf of Mexico Red Grouper. Each line represents the change in negative log-likelihood value for each of the data sources fit in the model across the range of fixed initial fishing mortality values tested in the profile diagnostic run.

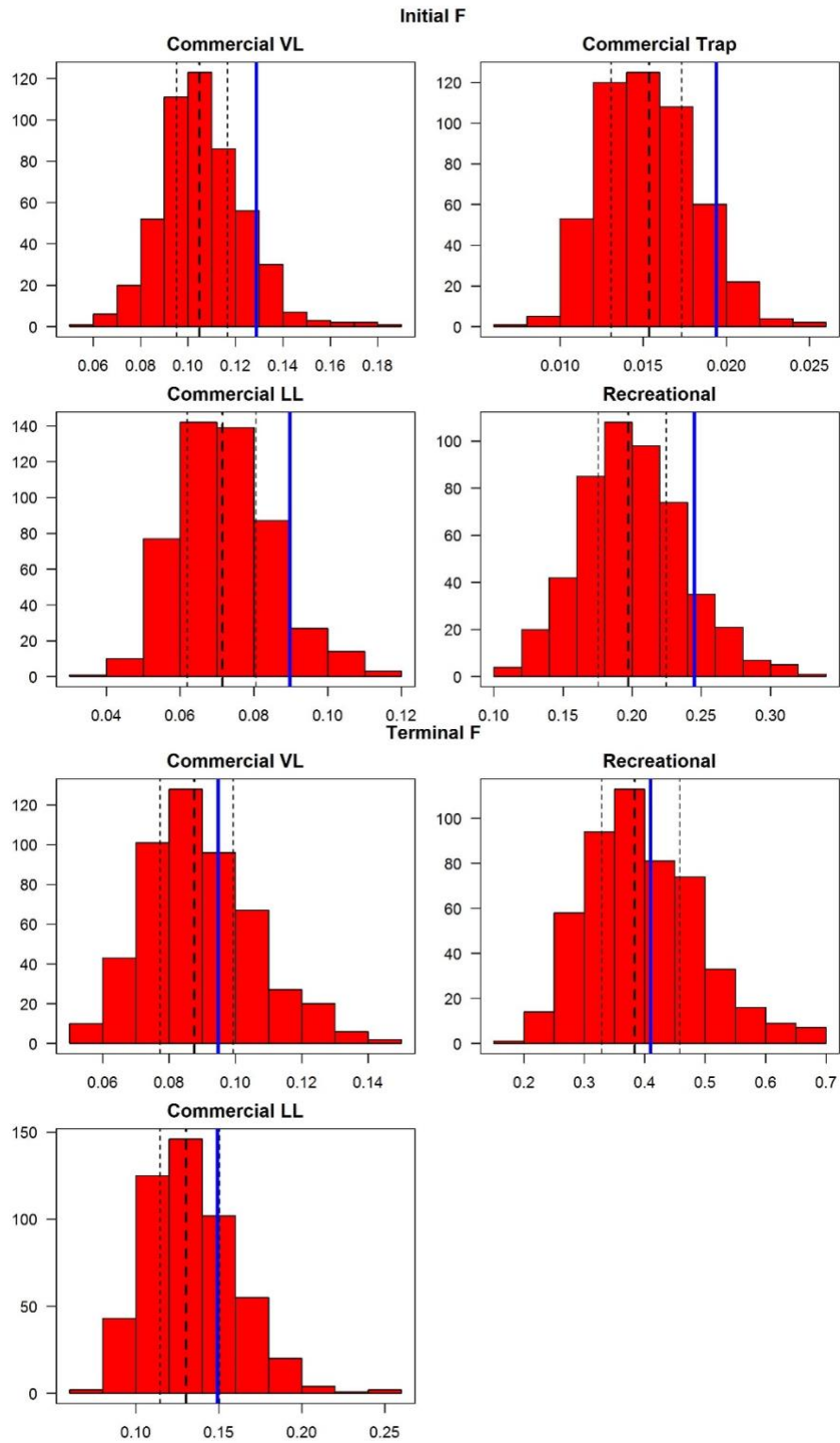


**Figure 4.54.** Trends in relative spawning stock biomass (SSB is in relative number of eggs) of Gulf of Mexico Red Grouper for each of the profile likelihood runs. The panels from top to bottom represent the range of values for initial  $F_s$  for the commercial vertical line, commercial longline, commercial trap, and recreational fisheries.

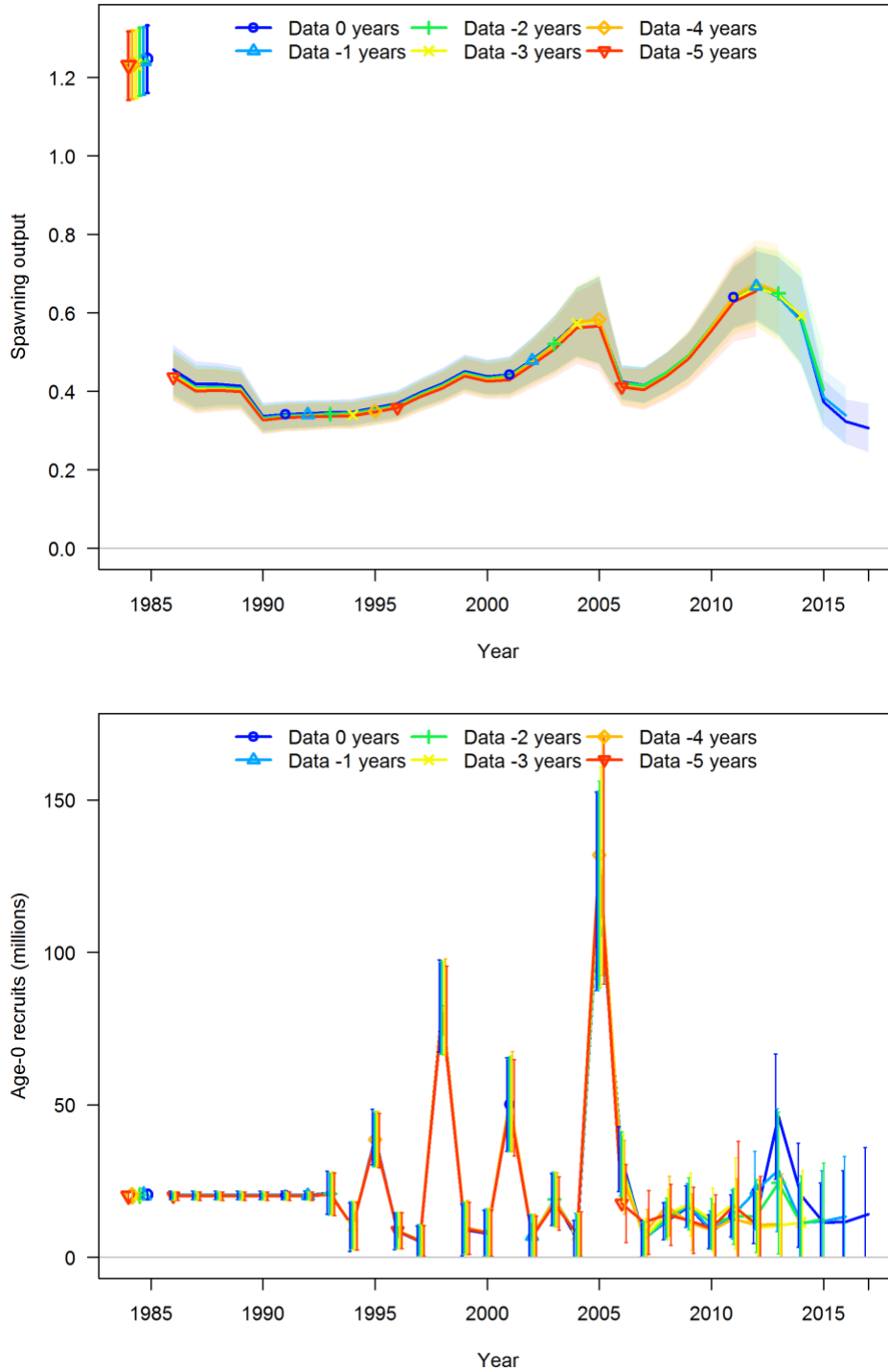


**Figure 4.55.** Histograms of derived quantities and estimated parameters for the 500 bootstrap runs for the Gulf of Mexico Red Grouper Base Model. The base model value is indicated by the blue solid vertical line, thin dashed lines represent the 25<sup>th</sup> and 75<sup>th</sup> percentiles, and the thick dashed line represents the median. SSB is in relative number of eggs.

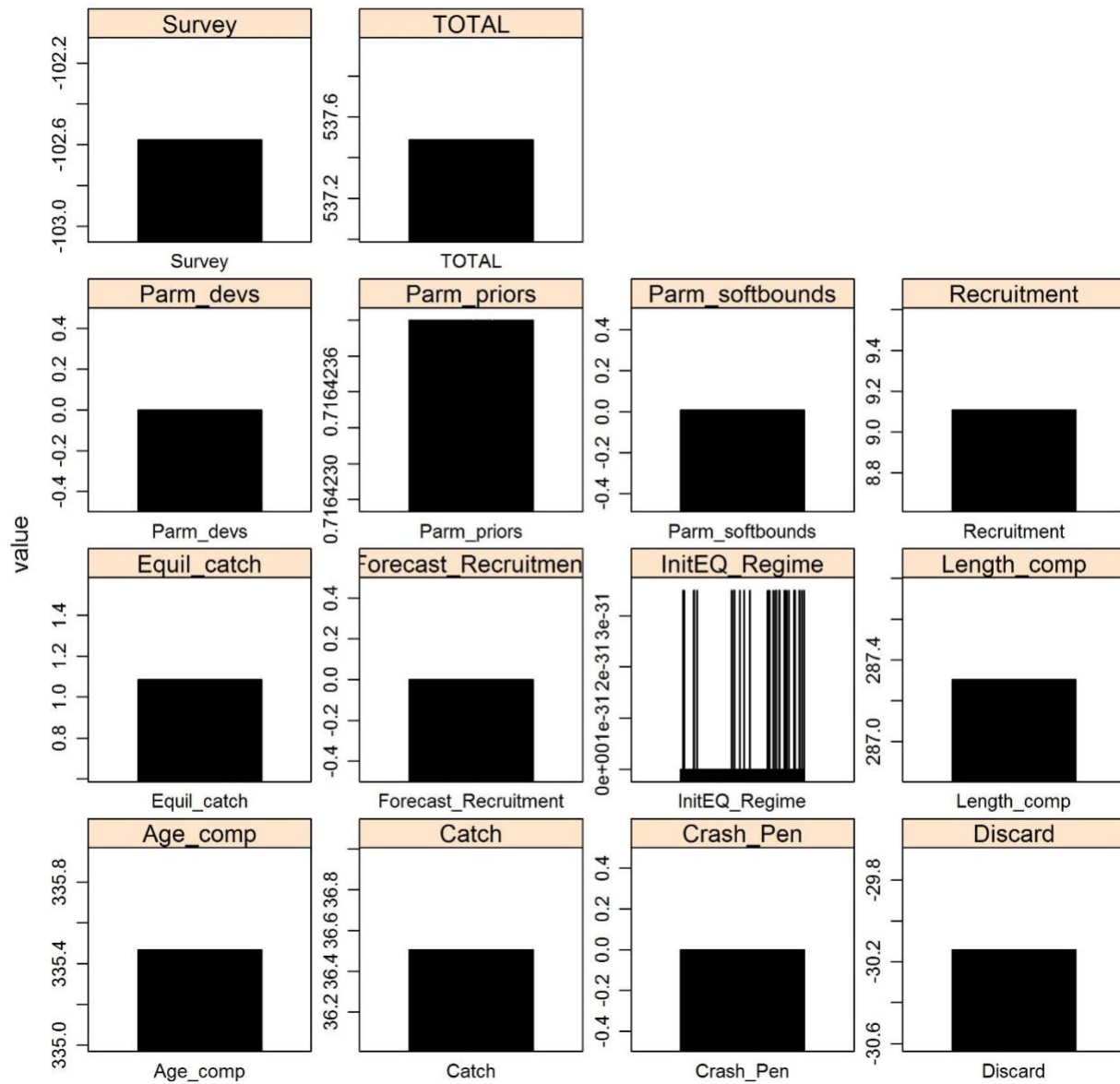




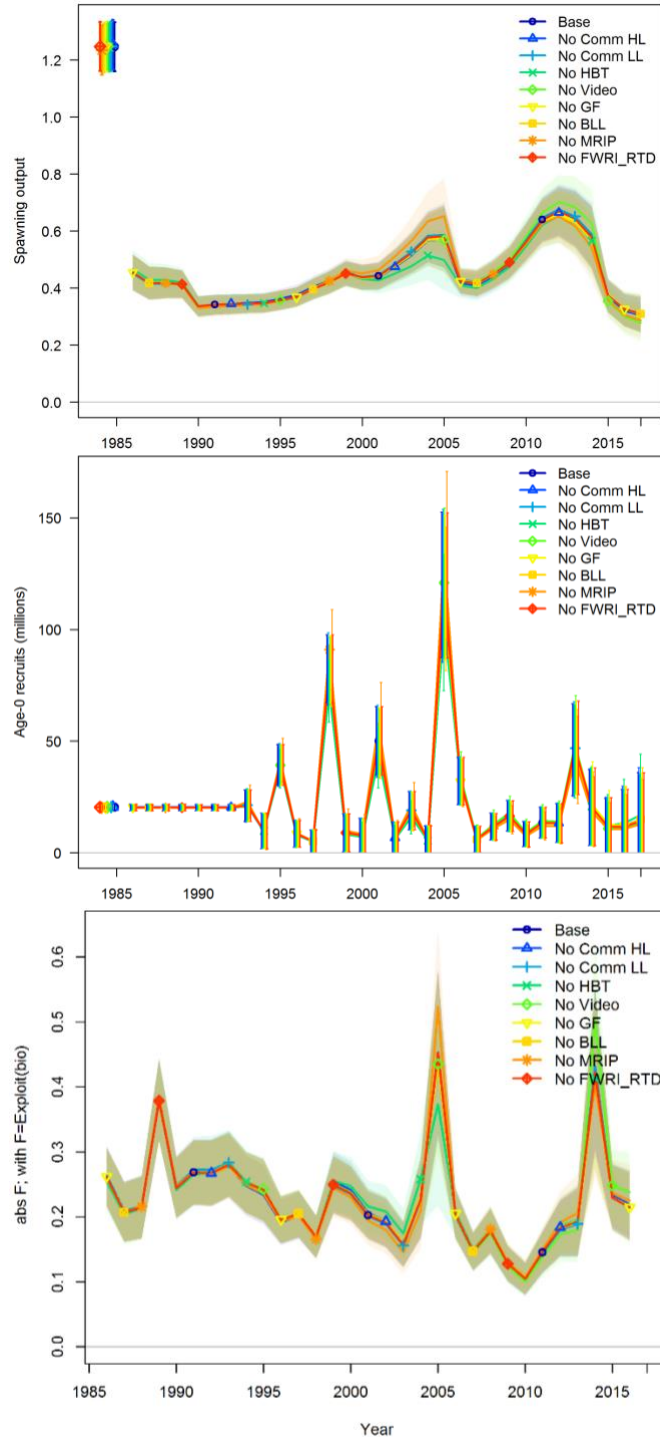
**Figure 4.56.** Histograms of initial and terminal fishing mortality rates for the 500 bootstrap runs for the Gulf of Mexico Red Grouper Base Model. The base model value is indicated by the blue vertical line, thin dashed lines represent the 25<sup>th</sup> and 75<sup>th</sup> percentiles, and the thick dashed line represents the median.



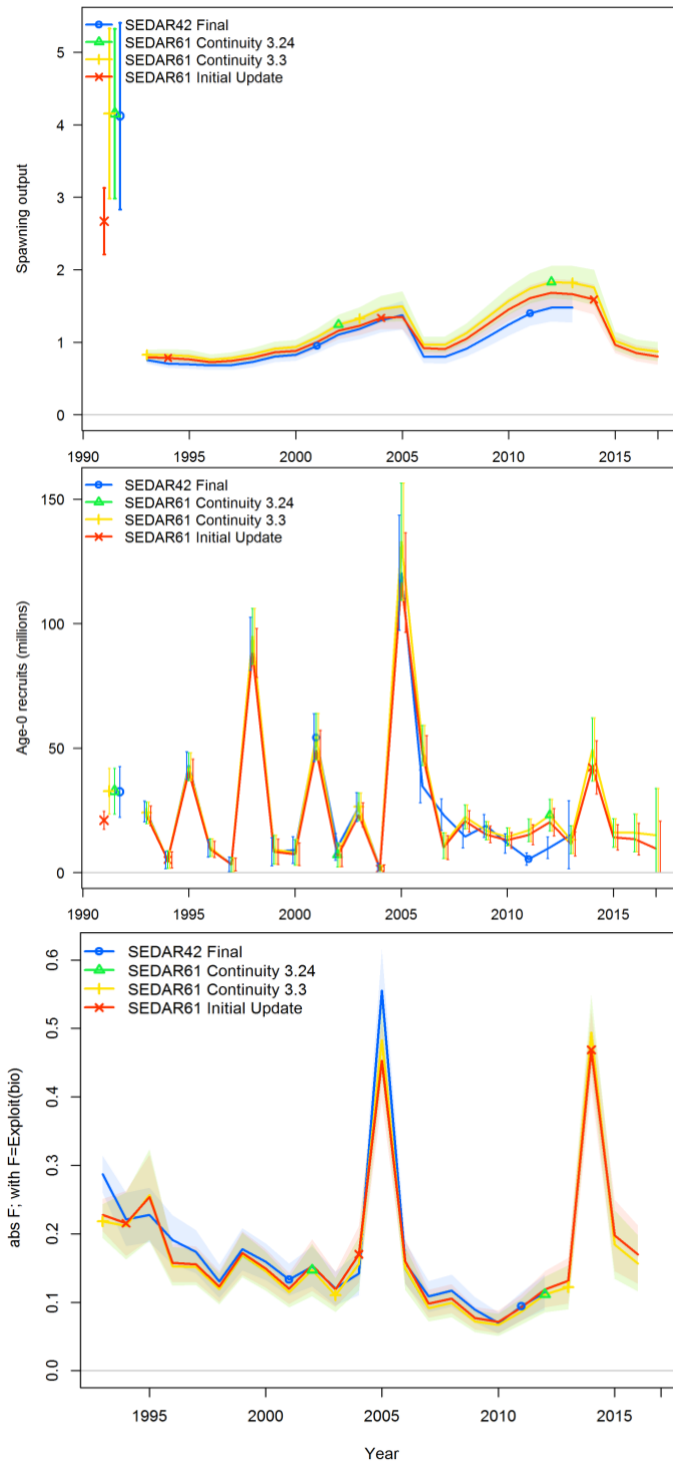
**Figure 4.57.** Results of a five year retrospective analysis for spawning biomass (relative number of eggs; top panel) and recruitment (millions of fish; bottom panel) for the Gulf of Mexico Red Grouper Base Model. There is no discernible systematic bias, because each data peel is not consistently over or underestimating any of the population quantities.



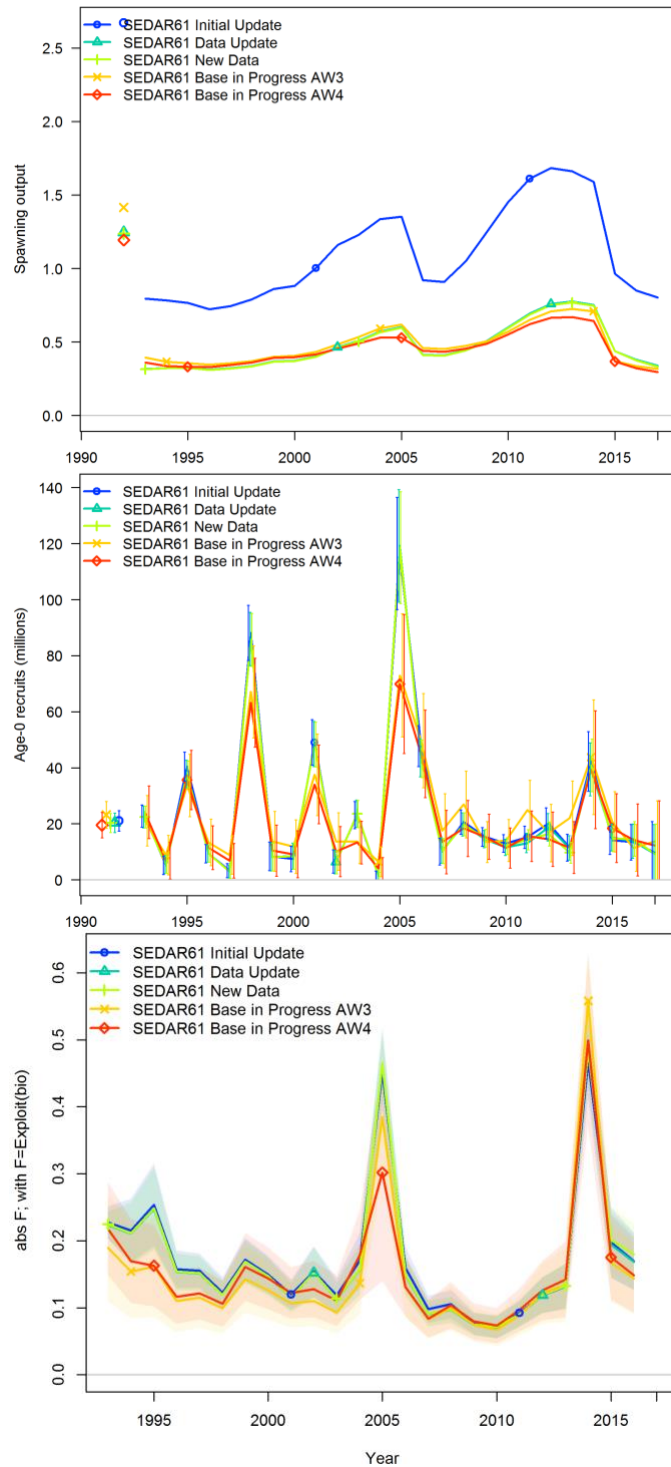
**Figure 4.58.** Results of the jitter analysis for various likelihood components for the Gulf of Mexico Red Grouper Base Model. Each panel gives the results of 200 model runs where the starting parameter values for each run were randomly changed (‘jittered’) by 10% from the base model best fit values.



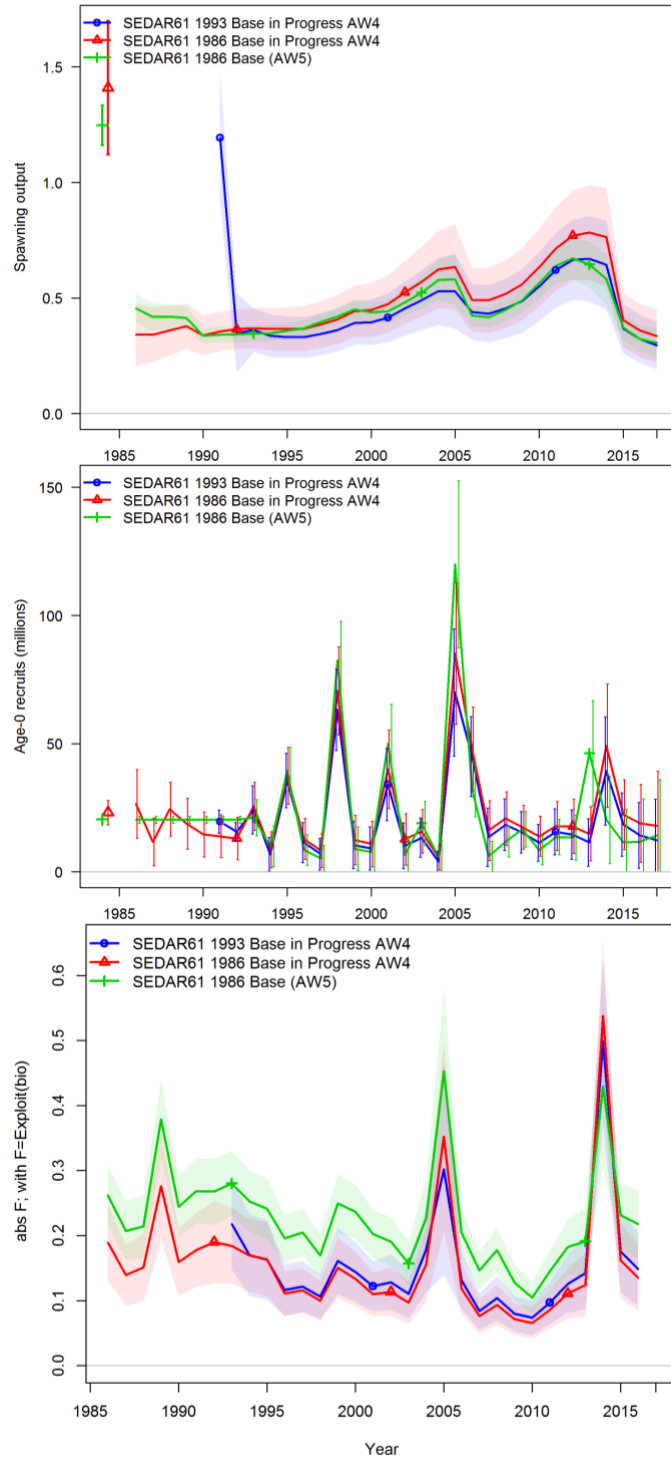
**Figure 4.59.** Results of a ‘jack-knife’ analysis with the fishery-dependent and independent indices for the Gulf of Mexico Red Grouper Base Model. Spawning stock biomass (relative number of eggs), recruitment (millions of fish) and fishing mortality (total biomass killed/total biomass, includes red tide mortality in 2005 and 2014) are shown. The results indicate that all of the indices are generally in agreement and no one index seems to be driving the assessment.



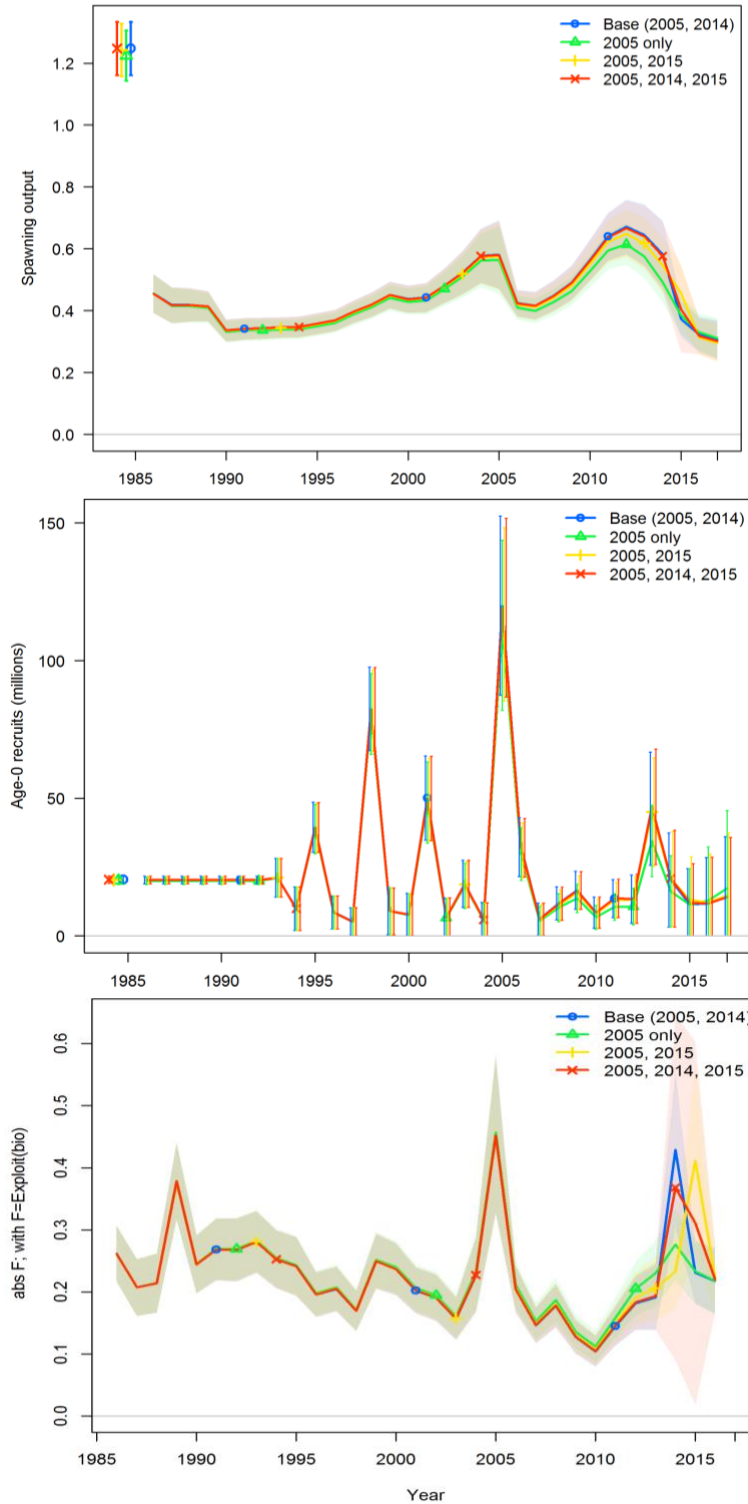
**Figure 4.60.** Results of the SEDAR61 continuity model building exercise (Stage 1) for Gulf of Mexico Red Grouper. Shown are spawning stock biomass (relative number of eggs), recruitment (millions of fish) and fishing mortality (total biomass killed/total biomass, includes red tide mortality in 2005 and 2014). Details on specific changes in each model configuration are provided in **Table 4.6**.



**Figure 4.61.** Results of the SEDAR61 Base Model building exercise through 1993 (Stage 2) for Gulf of Mexico Red Grouper. Shown are spawning stock biomass (relative number of eggs), recruitment (millions of fish) and fishing mortality (total biomass killed/total biomass, includes red tide mortality in 2005 and 2014). Details on specific changes in each model configuration are provided in **Table 4.6**.

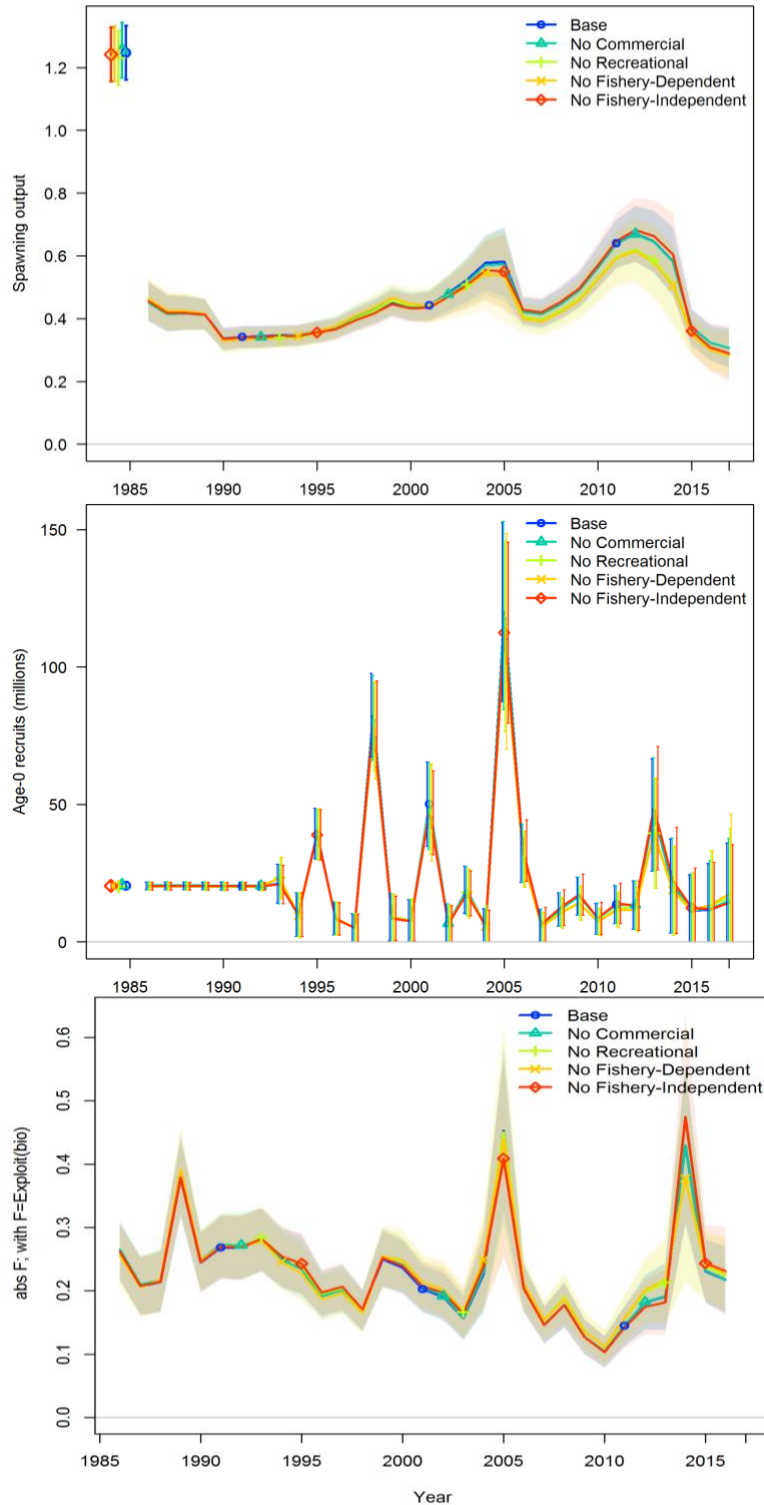


**Figure 4.62.** Results of the SEDAR61 Base Model building exercise through 1986 (Stage 3) for Gulf of Mexico Red Grouper. Shown are spawning stock biomass (relative number of eggs), recruitment (millions of fish) and fishing mortality (total biomass killed/total biomass, includes red tide mortality in 2005 and 2014). Details on specific changes in each model configuration are provided in **Table 4.6**.

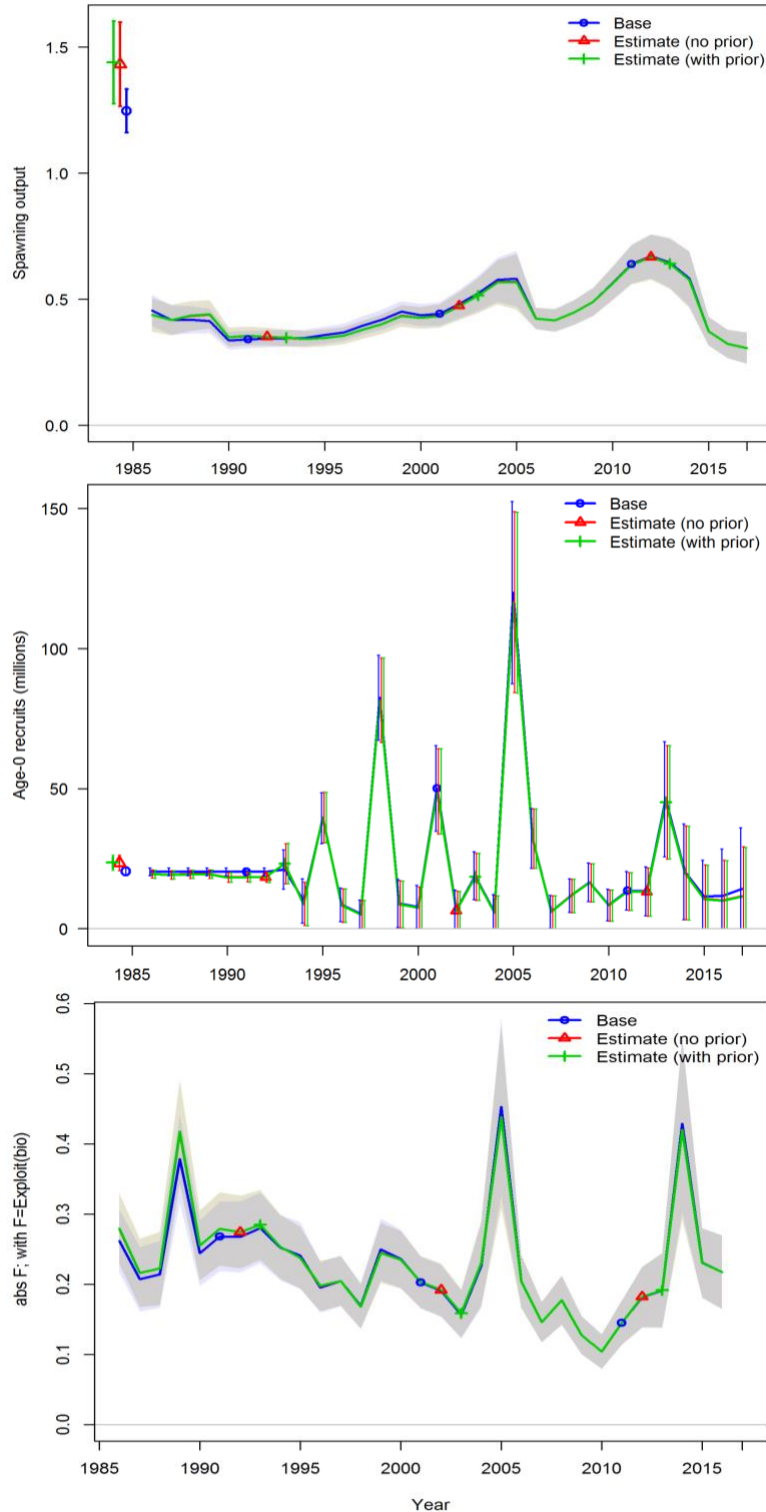


**Figure 4.63.** Estimates of spawning stock biomass (relative number of eggs), age-0 recruits (millions of fish), and fishing mortality (total biomass killed/total biomass, includes red tide mortality in 2005 and 2014) for the red tide year sensitivity runs conducted for the Gulf of Mexico Red Grouper Base Model.

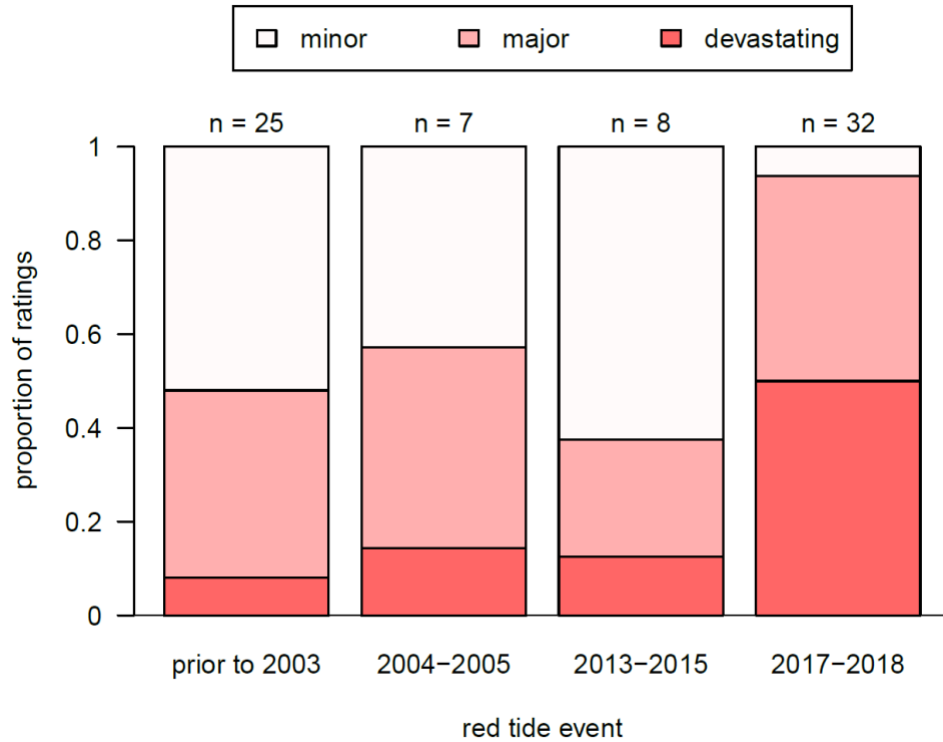




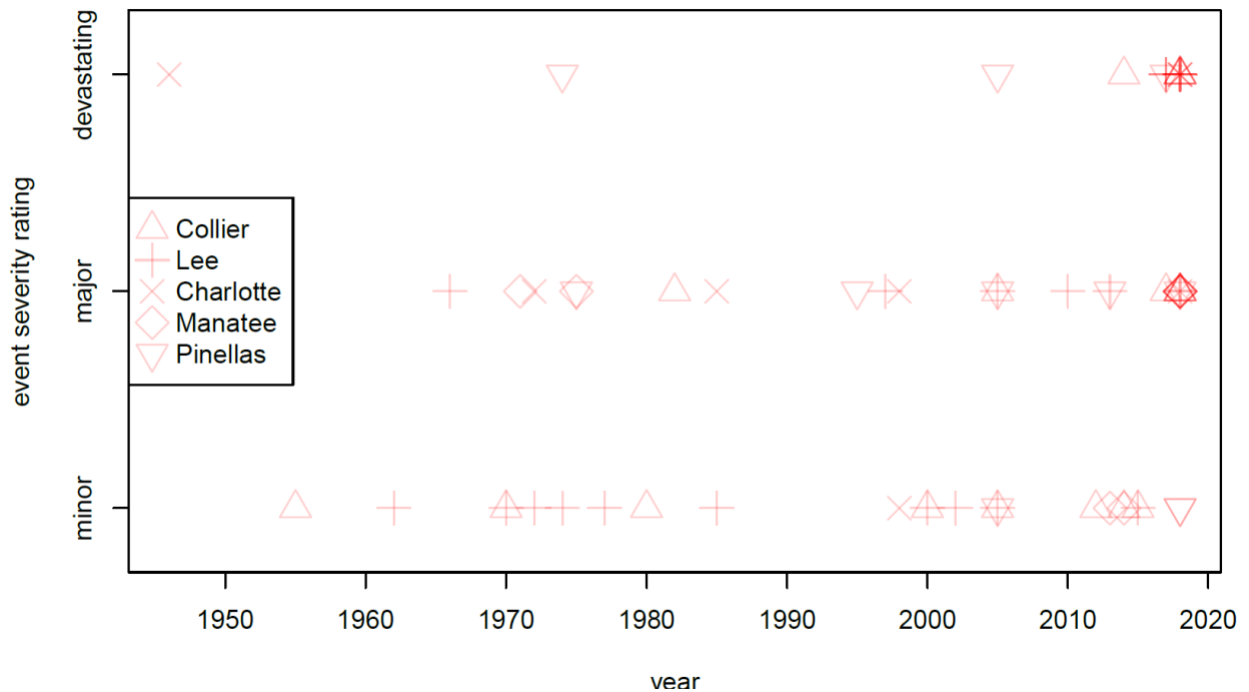
**Figure 4.64.** Estimates of spawning stock biomass (relative number of eggs), age-0 recruits (millions of fish), and fishing mortality (total biomass killed/total biomass, includes red tide mortality in 2005 and 2014) for the index group removal sensitivity runs conducted for the Gulf of Mexico Red Grouper Base Model.



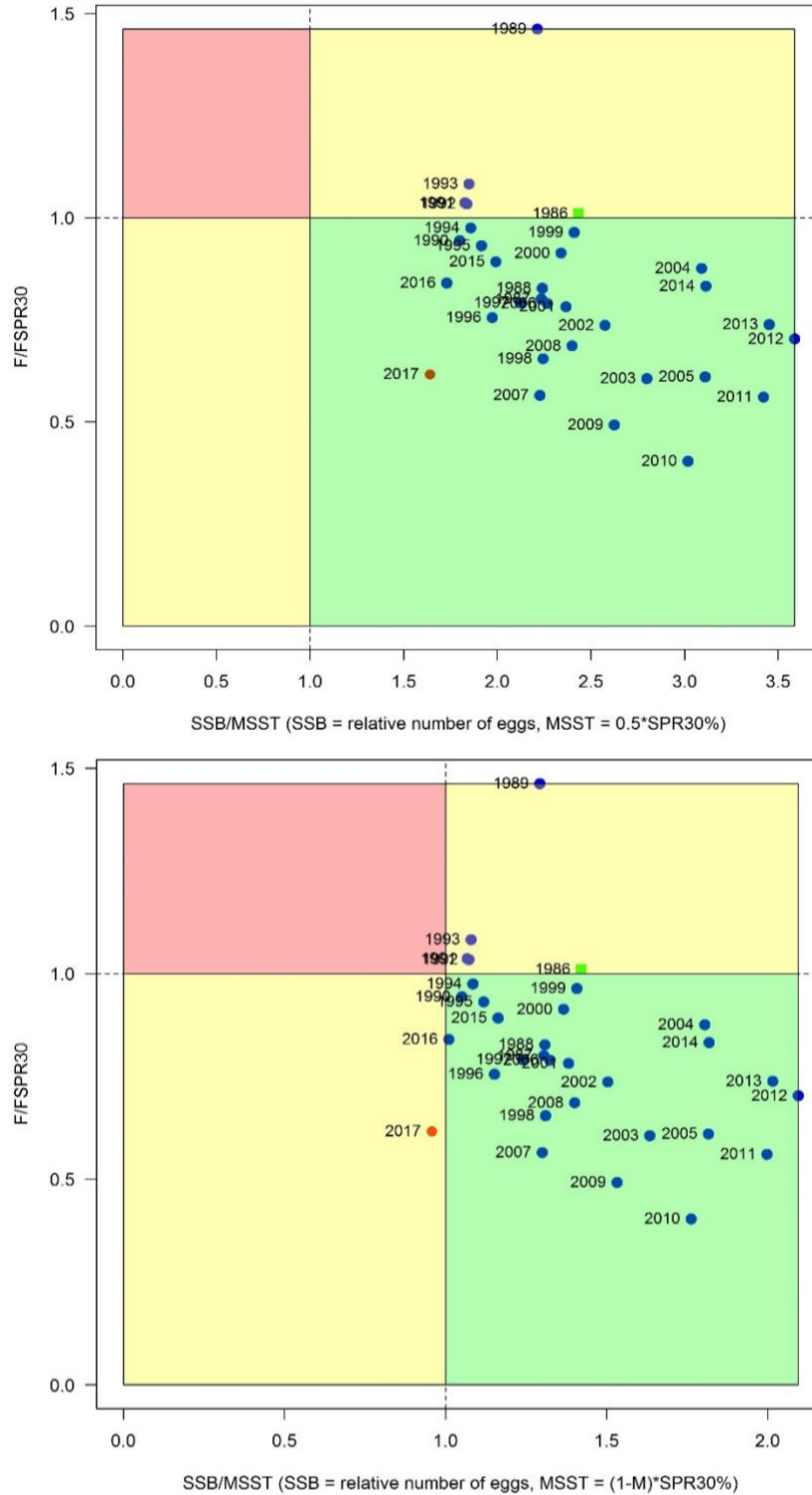
**Figure 4.65.** Estimates of spawning stock biomass (relative number of eggs), age-0 recruits (millions of fish), and fishing mortality (total biomass killed/total biomass, includes red tide mortality in 2005 and 2014) for the estimating steepness sensitivity runs conducted for the Gulf of Mexico Red Grouper Base Model.



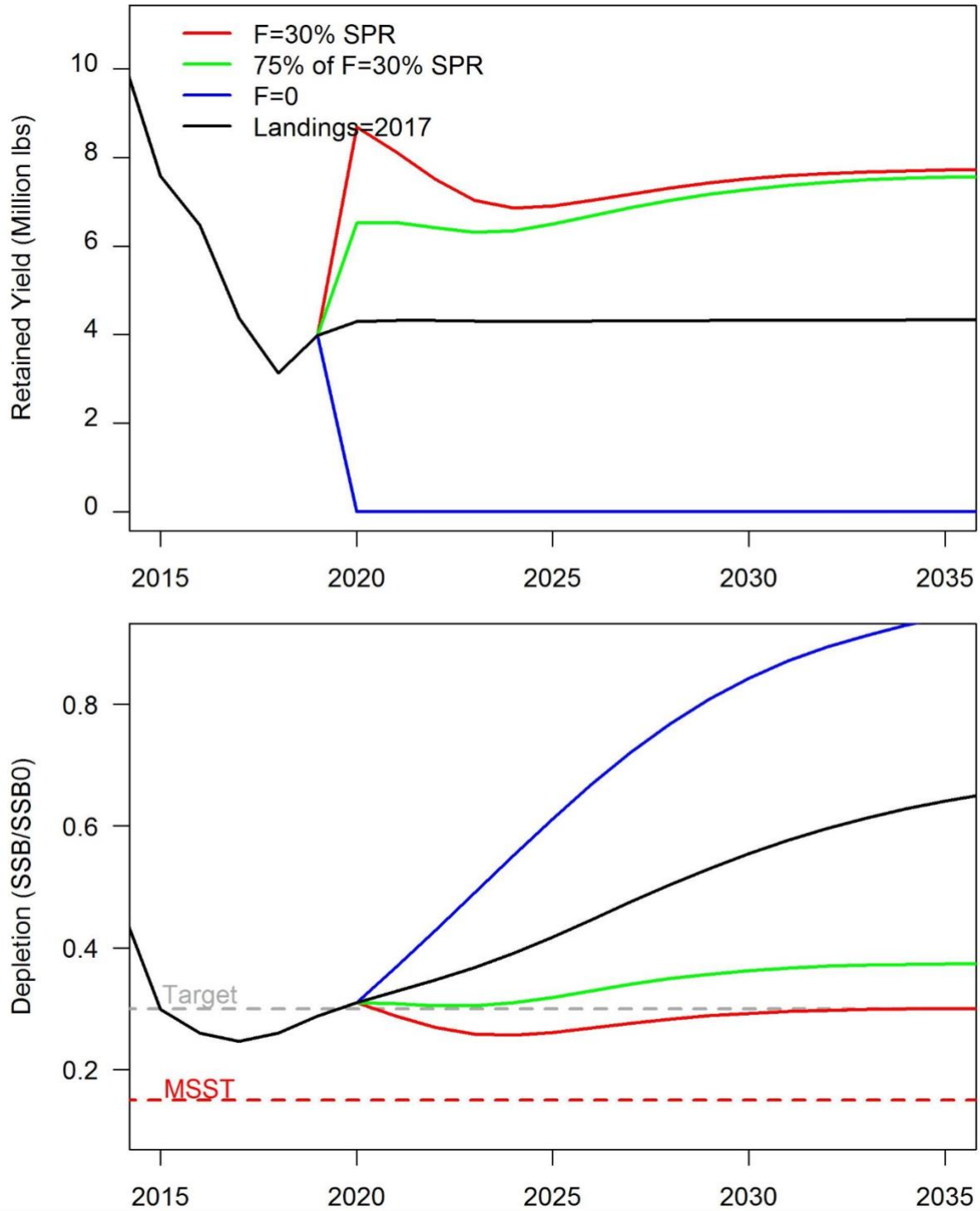
**Figure 5.1.** Categorized severity ratings of recent and past red tide events, as given by individual interviewees. See **Table 5.3** for a list of descriptors used to categorize severity.



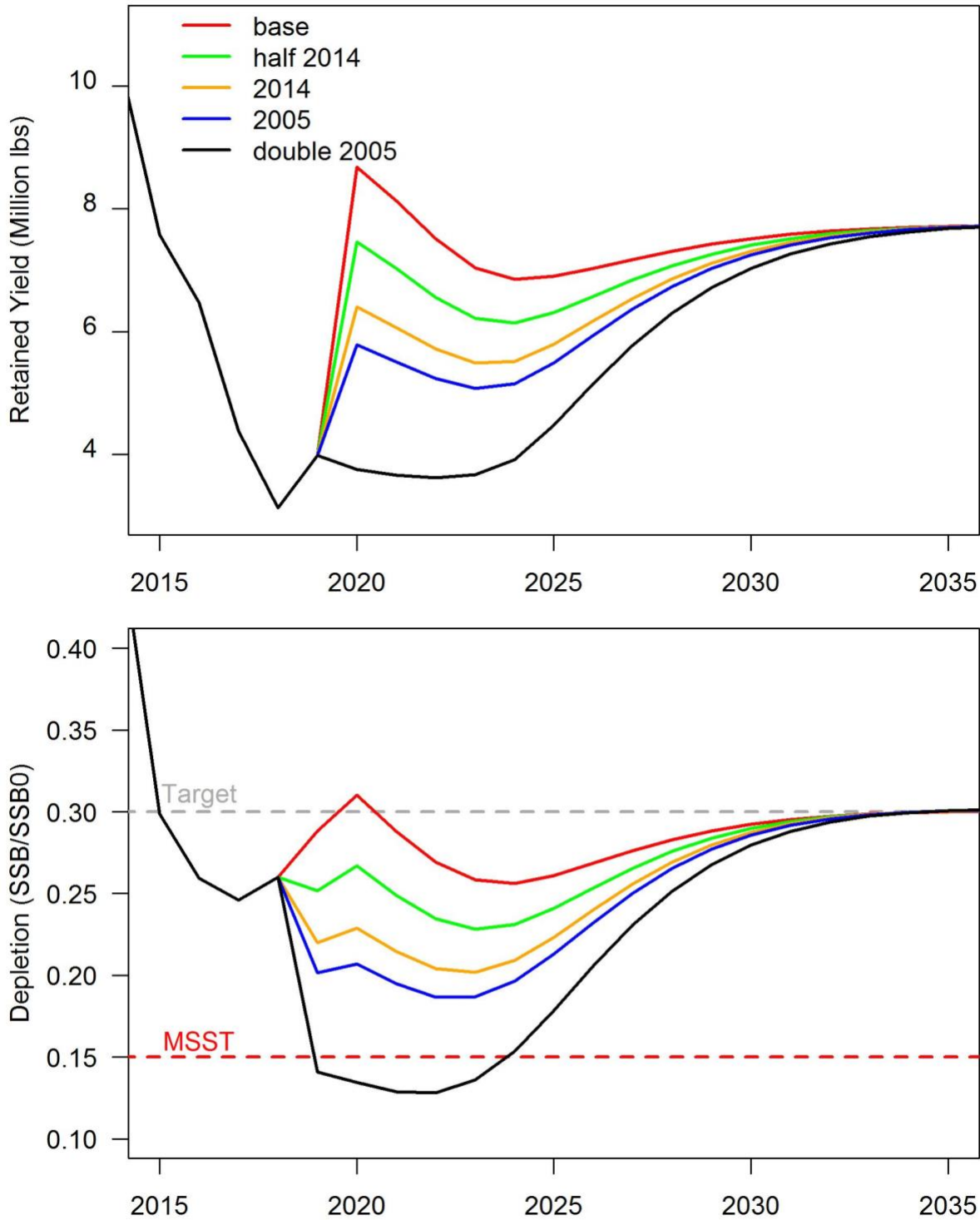
**Figure 5.2.** Individual severity ratings for described red tide events, plotted by the identified year of the event. Each point represents an individual event described by an interviewee; darker colors indicate overlying points. Shapes denote the county of residence of the interviewee.



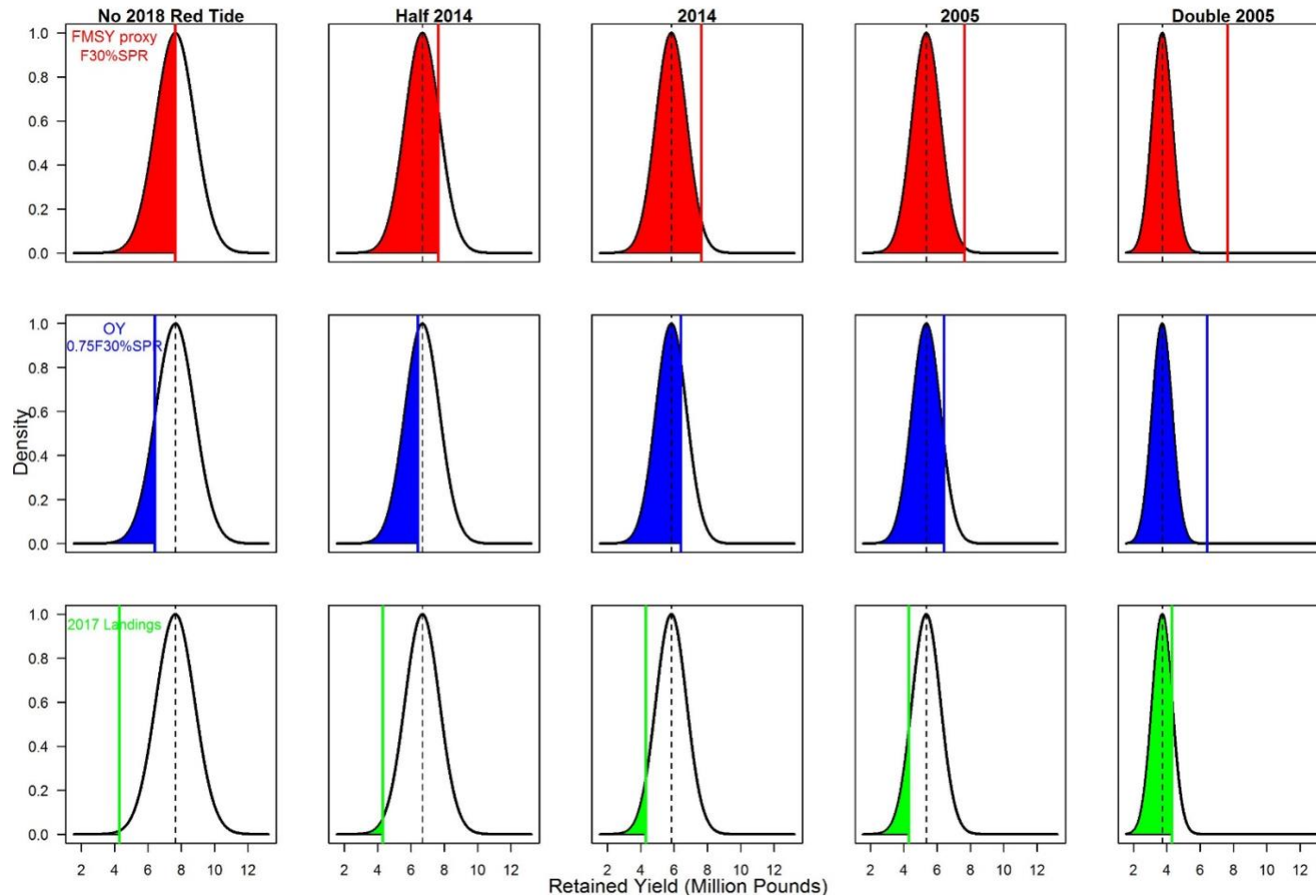
**Figure 5.3.** Kobe plot illustrating the time series of stock status of Gulf of Mexico Red Grouper in 2017 for the the SEDAR61 Base Model using the new definition of MSST ( $0.5 \cdot SSB_{SPR30\%}$ ; Upper Panel) and the old definition of MSST ( $[1 - M] \cdot SSB_{SPR30\%}$ .) Lower Panel).



**Figure 5.4.** Overfishing limit (retained yield; top panel) and resulting Depletion (bottom panel) for projections assuming recent average recruitment and no red tide mortality in 2018. Scenarios shown include achieving (1) an SPR of 30% in equilibrium ( $F_{SPR30\%}$ ), (2) Optimum Yield ( $0.75 * F_{SPR30\%}$ ), (3)  $F = 0$ , and (4) Landings fixed at 2017 levels.

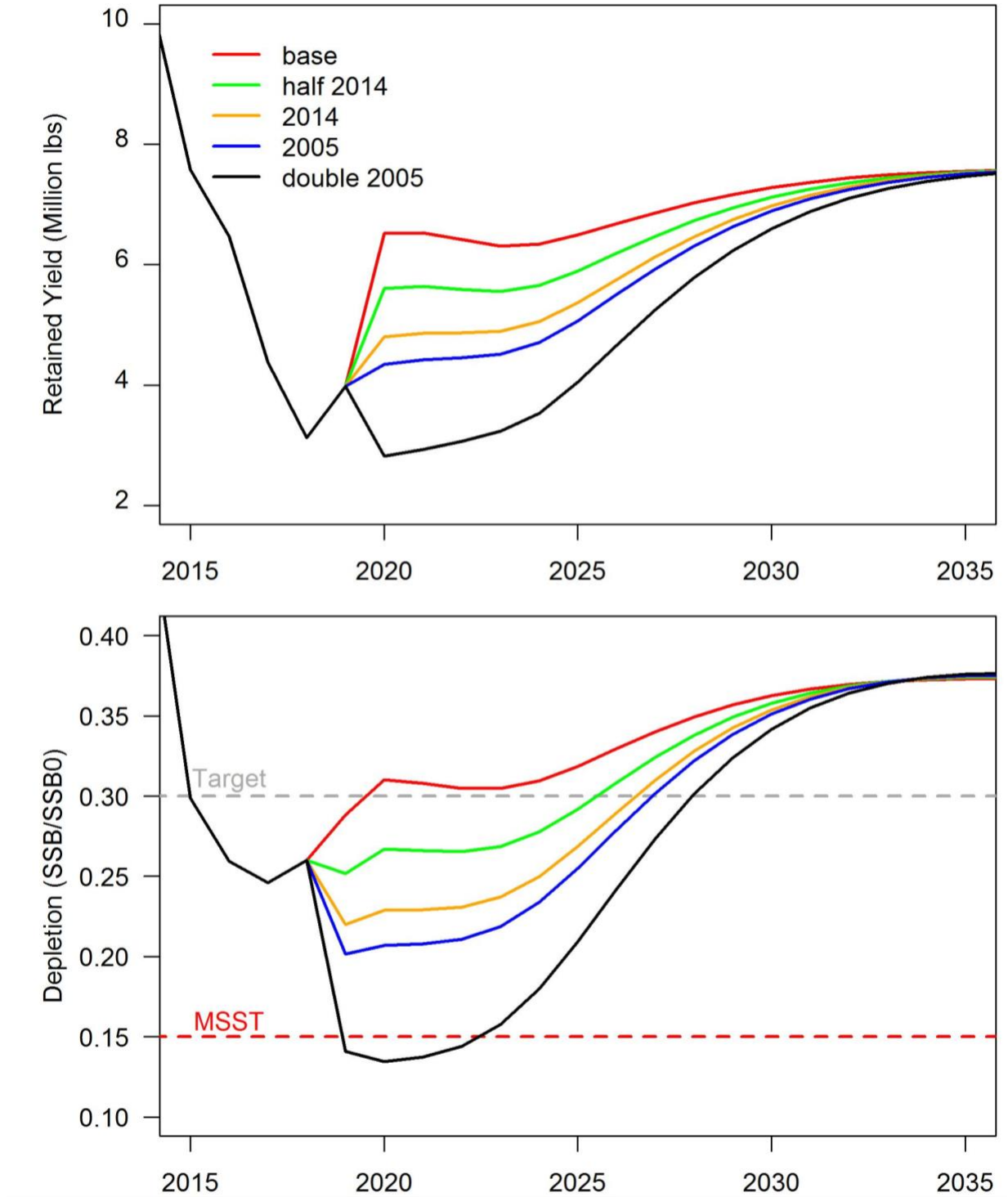


**Figure 5.5.** Overfishing limit (retained yield; top panel) and resulting Depletion (bottom panel) for projections achieving SPR30% in equilibrium and assuming recent average recruitment. Red tide scenarios for 2018 include: (1) Base, not severe (0); (2) half of 2014 (0.1285); (3) same as 2014 (0.257), (4) same as 2005 (0.339), and (5) double 2005 (0.678).



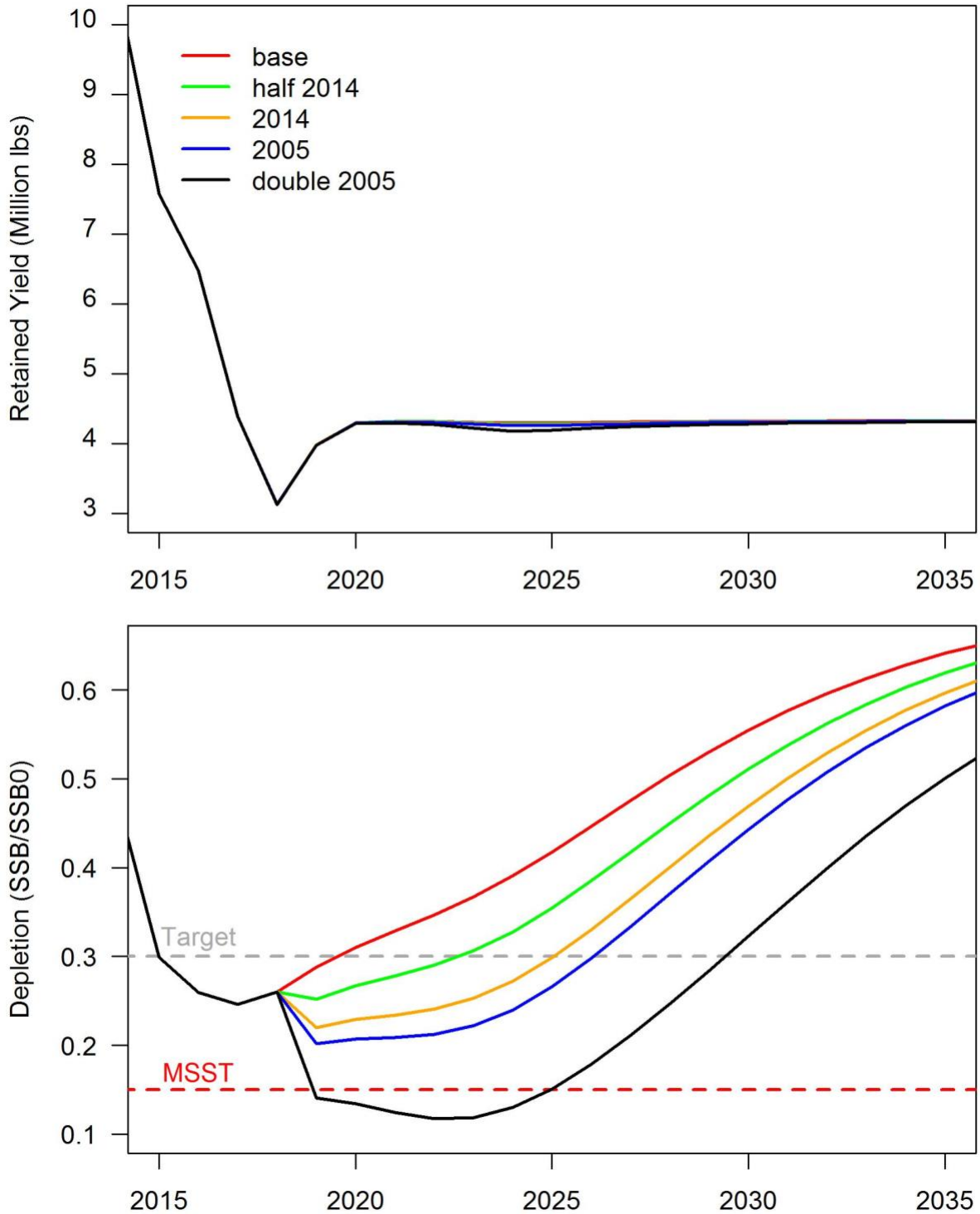
**Figure 5.6.** Estimated probability of overfishing (shaded region) in 2020 through 2024 for the Gulf of Mexico Red Grouper SEDAR61 Base Model under projections that achieve an SPR of 30% in equilibrium (top panels), Optimum Yield (middle panels), and maintain 2017 (bottom panels) catch levels. Solid vertical lines correspond to catch levels provided in **Table 5.7**. Red tide scenarios for 2018 include: (1) Base, not severe (0); (2) half of 2014 (0.1285); (3) same as 2014 (0.257), (4) same as 2005 (0.339), and (5) double 2005 (0.678).





**Figure 5.7.** Overfishing limit (retained yield; top panel) and resulting Depletion (bottom panel) for projections achieving Optimum Yield and assuming recent average recruitment. Red tide scenarios for 2018 include: (1) Base, not severe (0); (2) half of 2014 (0.1285); (3) same as 2014 (0.257), (4) same as 2005 (0.339), and (5) double 2005 (0.678).





**Figure 5.8.** Overfishing limit (retained yield; top panel) and resulting Depletion (bottom panel) for projections with landings fixed at current levels and assuming recent average recruitment. Red tide scenarios for 2018 include: (1) Base, not severe (0); (2) half of 2014 (0.1285); (3) same as 2014 (0.257), (4) same as 2005 (0.339), and (5) double 2005 (0.678).